

Conversion tables

LENGTH			
mm	m	inches	feet
1	0.001	0.0394	0.0033
1000	1	39.3701	3.2808
25.4	0.0254	1	0.0833
304.8	0.3048	12	1

SURFACE				
m ²	cm ²	mm ²	sq.in	sq.ft
1	10000	1000000	1550	10.76
0.0001	1	100	0.155	0.0011
0.000001	0.01	1	0.00155	1.076E-05
0.0006	6.4516	645.16	1	0.0069
0.0929	929.0304	92903.04	144	1

VOLUME							
m ³	dm ³ (liter)	cm ³	mm ³	in ³	ft ³	gallons (US)	fl oz
1	1000	1000000	1000000000	61.0237441	35.3147	264.1700	33813.7
0.001	1	1000	1000000	61.0237	0.0353	0.2642	33.8137
0.000001	0.001	1	1000	0.0610	3.53147E-05	0.0003	0.0338
0.000000001	0.000001	0.001	1	6.10237E-05	3.53147E-08	2.6417E-07	3.38137E-05
1.63871E-05	0.0164	16.3871	16.3870640	1	0.0006	0.0043	0.5541
0.028316847	28.3168	28.316	28.316.846.5920	1.12280000	1	7.4805	957.4974
0.003785441	3.7854	3.7854	3.785.441.2800	0.2310018	0.1337	1	127.9998
2.95738E-05	0.0296	29.57	29.573.8118	1.8047	0.0010	0.0078	1

LOAD				
N	kN	Tonf	kgf	Lbf
1	0.001	0.0001	0.1020	0.2248
1000	1	0.1020	101.9716	224.8090
9806.65	9.8067	1	1000	2.204.6234
9.8067	0.0098	0.001	1	2.2046
4.4482	0.0044	0.0005	0.4536	1

TORQUE							
Nm	Ncm	Nmm	daN.m	daN.cm	kgf.cm	in.lbf	ft.lbf
1	100	1000	0.1	10	10.1972	8.8507	0.7376
0.01	1	10	0.001	0.1	0.1020	0.0885	0.0074
0.001	0.1	1	0.0001	0.01	0.0102	0.0089	0.0007
10	1000	10000	1	100	101.9716	88.5075	7.3756
0.1	10	100	0.01	1	1.0197	0.8851	0.0738
0.0981	9.8067	98.0665	0.0098	0.9807	1	0.8680	0.0723
0.1130	11.2985	112.9848	0.0113	1.1298	1.1521	1	0.0833
1.3558	135.5817	1.355.8175	0.1356	13.5582	13.8255	12	1

STIFFNESS		
N/mm	N/μm	lbf/in x 1E6
1	1000	5.7101
0.001	1	0.0057
0.1751	175.1268	1

LINEAR SPEED								
m/s	mm/s	m/min	km/h	in/s	in/min	ft/s	ft/min	mph
1	1000	60	3.6	39.3701	2.362.2047	3.2808	196.8504	2.2369
0.001	1	0.06	0.0036	0.0394	2.3622	0.0033	0.1969	0.0022
0.0167	16.6667	1	0.06	0.6562	39.3701	0.0547	3.2808	0.0373
0.2778	277.7778	16.6667	1	10.9361	656.1680	0.9113	54.6807	0.6214
0.0254	25.4	1.524	0.0914	1	60	0.0833	5	0.0568
0.0004	0.4233	0.0254	0.0015	0.0167	1	0.0014	0.0833	0.0009
0.3048	304.8	18.288	1.0973	12	720	1	60	0.6818
0.00508	5.08	0.3048	0.0183	0.2	12	0.0167	1	0.0114
0.4470	447.0389	26.8223	1.6093	17.6000	1.055.9974	1.4667	87.9998	1

VIS À ROULEAUX SATELLITES



SATELLITE ROLLER SCREWS

catalogue 2019



ROLLVIS SA

136, ch. du Pont-du-Centenaire
CH-1228 Plan-les-Ouates
GENEVA - SWITZERLAND
Correspondence: post box 590
CH - 1212 GRAND-LANCY 1

Tél. +41 (0)22 706 90 40
Fax +41 (0)22 706 90 49

Email : info@rollvis.com
Website: www.rollvis.com

catalogue 2019

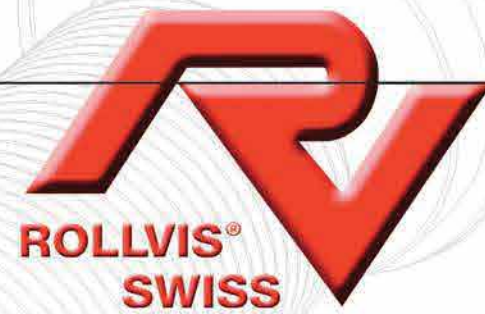

SATELLITE ROLLER SCREWS



Established in 1970, ROLLVIS SA quickly started to focus exclusively on design, manufacturing and marketing of satellite roller screws under the trademark «Rollvis swiss». Our products represent today the reference for high performance linear motion applications. Our factory is equipped with the most powerful machines to achieve to lowest tolerances on roller screws from very small quantities to larger batches. Following a continuous improvement path, Rollvis SA never stopped in investing in new manufacturing technologies and skills in business park of Plan-les-Ouates in Geneva. The Rollvis high tech spirit and the scale of the company have always been preserved to ensure the best reactivity, flexibility and support to customer requirements. Five decades of experience combined with the latest technologies enable Rollvis screws to be the preferred choice in many demanding or complex applications for industrial, aerospace or defense applications and for any segment where the best is required.



Roller screw expertise for aeronautics, space and Defense industry



Optronics and Mechatronics
Lifting Equipment and positioning systems
Special machines



Aircrafts
Helicopters
Unmanned vehicles
Launchers
Flight controls



Satellites
Telescops
Landing gears
Actuators
Defense

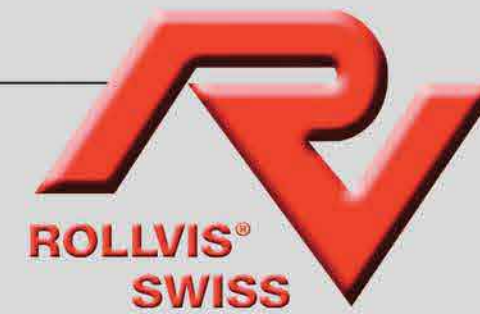

Today ROLLVIS is certified

ISO 9001 : 2015

EN 9100 : 2016

Certification



Application data list for roller screws

Operation conditions :

Number of screws supporting the lead :

Max static load :

Max. dynamic load :

Typical load chart (function of the stroke, forward and reverse stroke) :

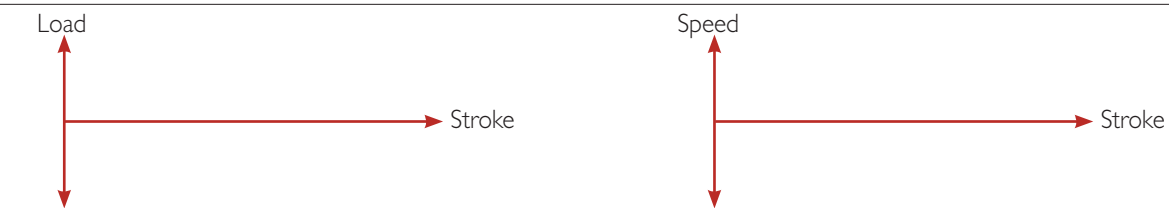

Maximal linear speed of the application :

Stroke :

length of screw :

Main load : Compression

Tension

Rotation : Nut

Screw shaft

Positioning of the screw : Vertical

Horizontal

Specific limitations : Vibration :

Shocks :

Expected lifetime Nb of cycles :

Total time required - years-month :

Environnement : Humidity / Fluid / Dust :

Temperature range :

Geometric limitations : Nut/Shaft max diameter/Length :

Interfaces :

Motor torque :

Lubrication requirement :

Preload - Backlash - Accuracy - Stiffness :

Lead accuracy : G5 (23_m/300mm) G3 (12_m/300mm) G1 (6_m/300mm)

Manufacturing tolerances (ISO 3408-3) : Classe 5 Classe 3 Classe 1

Axial backlash : Standard Without backlash Preloading/Stiffness

Nut : Flange Cylindrical Double Specific design

Mounting conditions of the roller screw

Fixed - Free : XX —

Fixde - Supported : XX — X

Fixed - Fixed : XX — XX

Supported - Supported : X — X

Notes / Remarks / Sketch :

Contents

To ensure that Rollvis roller screws always get benefits of the latest technologies, we have setup a new Research & Development department with a highly qualified team, the most recent softwares and technologies in manufacturing, control & testing. Products & Processes are permanently optimized to make Rollvis screws one of the best on the market regarding reliability, performance and availability. Production and Quality systems are organized according to the latest ISO and EN standards. Testimonials from many high end customers praise Rollvis screws for the outstanding quality. With a global presence on all continents through subsidiaries or high tech distributor partners, we offer support and deliver our solutions wherever you are.

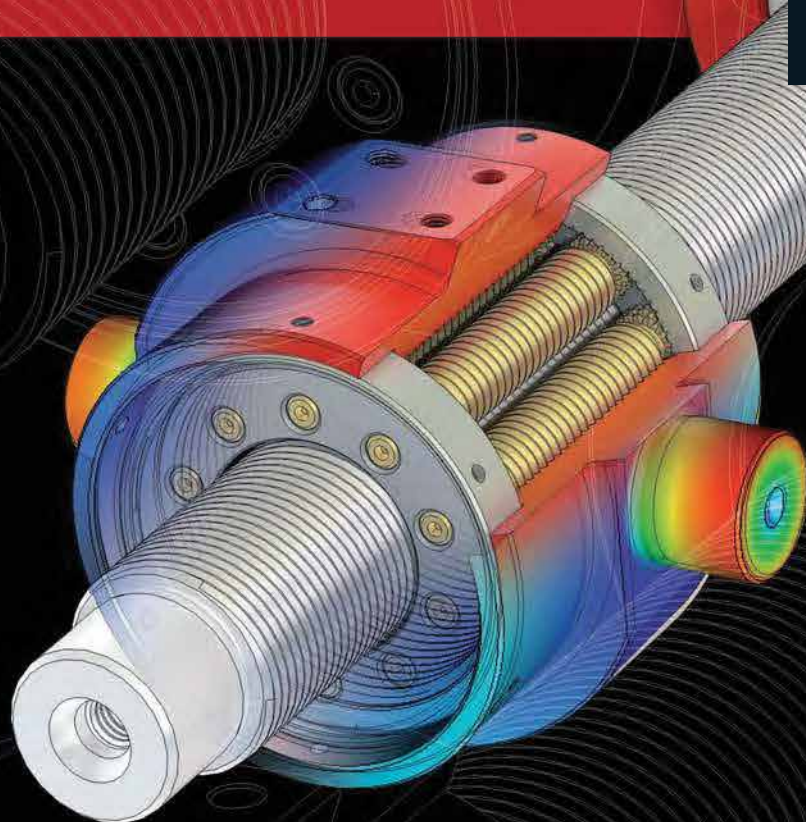

General Concepts	
• Satellite roller screws compared to ball screws	2
• Advantages of the Rollvis satellite roller screws	
• Examples of applications	
Types of roller screws	3 et 4
Identification system	5
Accuracy - Efficiency	6
Geometry	7
Preloading	8
Preloading examples	9
Mean speed and axial load	10
Nominal lifespan	11
Rigidity	12
Rotation speed	13
Driving torque	14 et 15
Calculation example	16 et 17
Lubrication	18 et 19
Handling advice	20

Preferred range

 Screw RV range	de 22 à 39
 Screw HRV range	de 40 à 45
 Screw RVI range	de 46 à 51
 Screw RVR range	de 52 à 57
 Screw RVD range	de 58 à 63
 Bearing units BU	de 64 à 68

RV Range

HRV Range

RVI Range

RVR Range

RVD Range

Bearing units BU

ROLLVIS satellite roller screws are used to transform rotary movements into linear movements and vice versa. The rolling elements are threaded rollers between the screw and the nut. The high number of points of contact enables satellite roller screws to support very heavy loads. The ROLLVIS range comprises satellite roller screws with no recirculation (types **RV** and **HRV**), inverted roller screws (type **RVI**), Differential roller screws (type **RVD**) and screws with recirculating rollers (type **RVR**). Bearing units are also proposed to equip the different roller screw designs.

Satellite roller screws compared to ball screws

Satellite roller screws mainly differentiate from ball screws because the load transfer elements are threaded rollers instead of balls. **the load transfer elements are threaded rollers.** The main advantage of satellite roller screws is that they have a much higher number of contact points and the thread profile is virtually equivalent to a very large ball diameter.

Load capacity and lifespan

The main advantage of roller screws compared to ball screws is that their admissible static and dynamic load capacities are higher.

The rolling function is ensured by threaded rollers instead of balls and the load is spread over a higher number of points of contact.

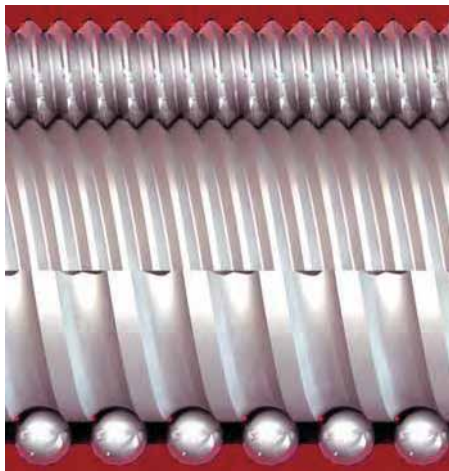

Speed & acceleration

Satellite roller screws can rotate much faster and support much greater acceleration.

RV satellite roller screws are designed so that the rollers are not recirculating. This means the mechanism can up to twice the rotation speed of a ball screw. Acceleration can reach up to 3g.

Lead & pitch

Planetary roller screws can be designed with much smaller leads than ball screws to ball screws.

The lead of roller screws (axial travel per turn) can be very small. It is typically limited to 1mm for small diameters of RV and cannot be reduced below a certain limit because threads require to be multi-starts. The thread pitch is defined as a function of the lead divided by the number of starts. RVR recirculating screws are single or double starts which give a pitch equal or at least half the lead. RVD differential screws could have lead down to few hundredths or tenths of mm if needed. Leads can have decimal values and the flexibility often enable direct drive. This is an advantage compared to ball screws. The lead can be chosen and realised without any geometrical changes of both the screw shaft and the nut body, which allows updates with minor changes while keeping very high load capacities. In a ball screw the minimum lead will be limited by the size of the ball that can fit in the thread. Small leads mean then small balls and very small capacity ratings consequently.

Rigidity & strength

The high number of contact points and the geometry of the contacts give a satellite roller screw greater rigidity and shock tolerance than a ball screw.

Advantages of the Rollvis satellite roller screws

- High axial load capacity
- Long lifespan
- High efficiency
- No backlash
- Extremely high rigidity
- Accuracy greater than 6 $\mu\text{m}/300\text{ mm}$
- High rotation speed (RV systems)
- Small leads (from 0.25 mm) with wide diameters (system RVR)
- Thin leads (to 0.02 mm) with medium diameters (system RVD)
- Fast acceleration and deceleration
- High reliability
- Easy customization
- Available in standard or Stainless materials

Examples of applications

Rollvis roller screws have successfully equipped many application segments such as:

- Machine tools
- Measuring machines
- Specific machines (benders)
- Robotics
- Aeronautics (aeroplanes and helicopters)
- Space (rockets and satellites)
- Defence (tanks, cannons, missiles, etc.)
- Oil industry
- Nuclear industry
- Medical
- Chemical industry
- Optical
- Telescopes
- Graphics
- Laser machines
- Injection moulding machines
- Car industry

Types of roller screws

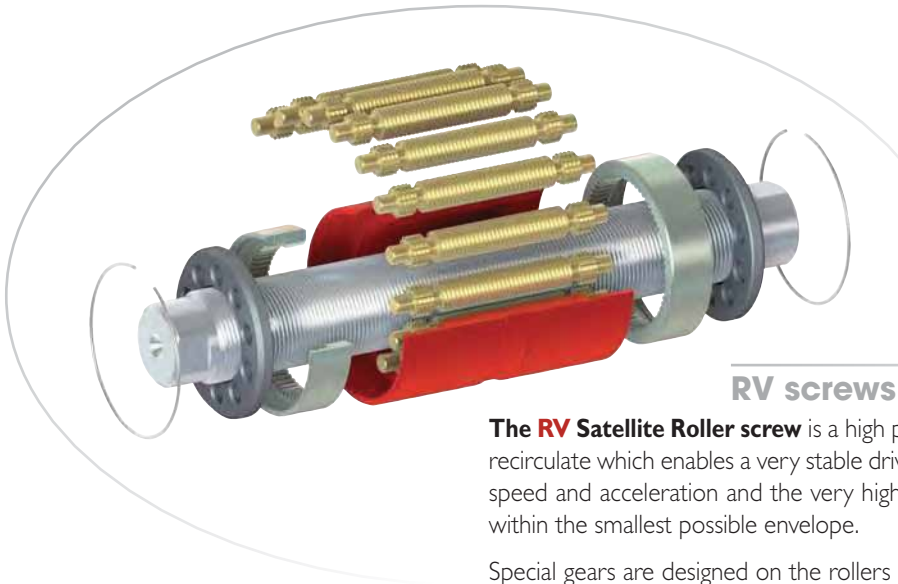

RV screws

The **RV Satellite Roller screw** is a high precision and robust assembly where rollers do not recirculate which enables a very stable driving torque. The screw can be used under very high speed and acceleration and the very high capacity ratings give an extended and reliable life within the smallest possible envelope.

Special gears are designed on the rollers and nut to maintain a good kinematics even in the most severe conditions.

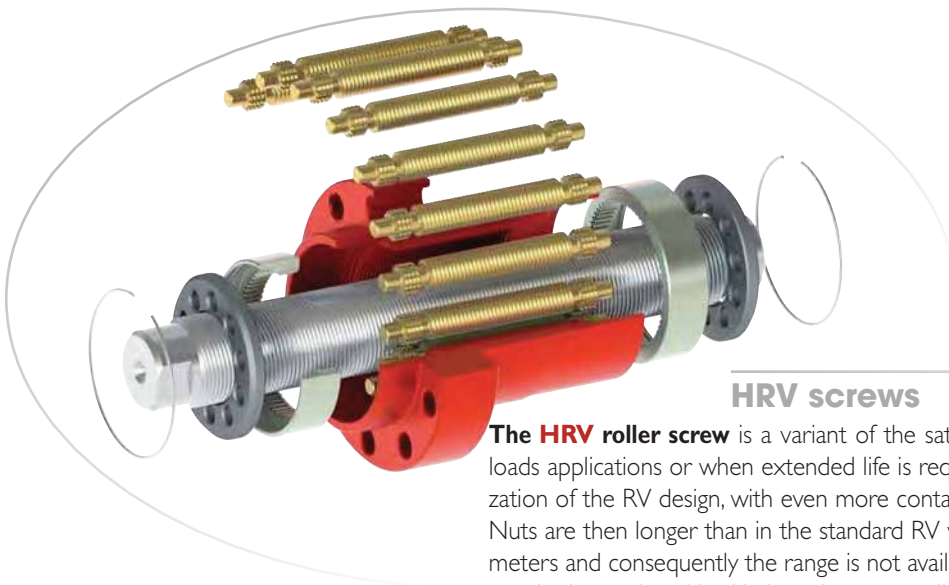

HRV screws

The **HRV roller screw** is a variant of the satellite roller screw RV designed for very high loads applications or when extended life is required. This design is based on specific optimization of the RV design, with even more contacts in the assembly and a new thread profile. Nuts are then longer than in the standard RV version. HRV series is designed for larger diameters and consequently the range is not available in split nut or with internal preload. Only standard or reduced backlash options are available.

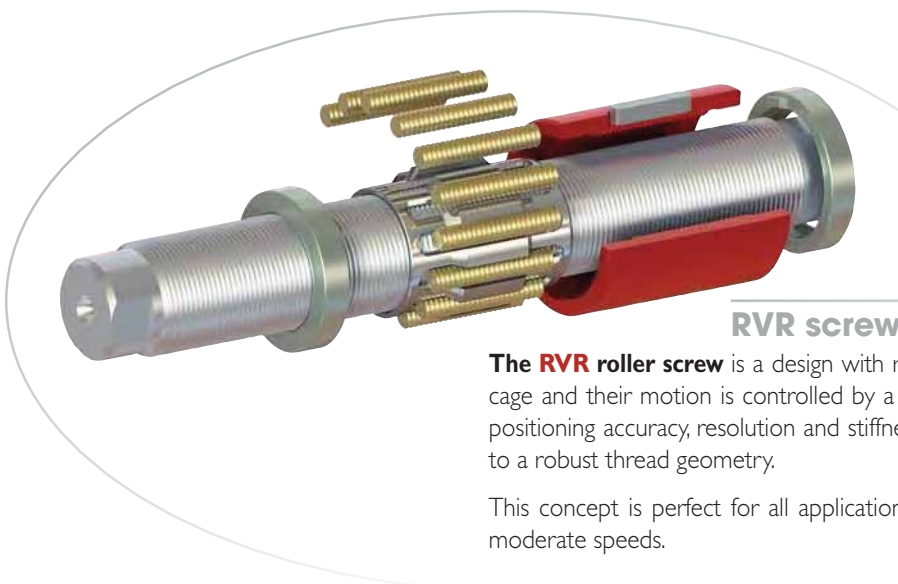

RVR screws

The **RVR roller screw** is a design with recirculating rollers. The rollers are guided within a cage and their motion is controlled by a set of cams. This design combines extremely high positioning accuracy, resolution and stiffness while capacity ratings are at the highest thanks to a robust thread geometry.

This concept is perfect for all applications that need a very high accuracy under small or moderate speeds.

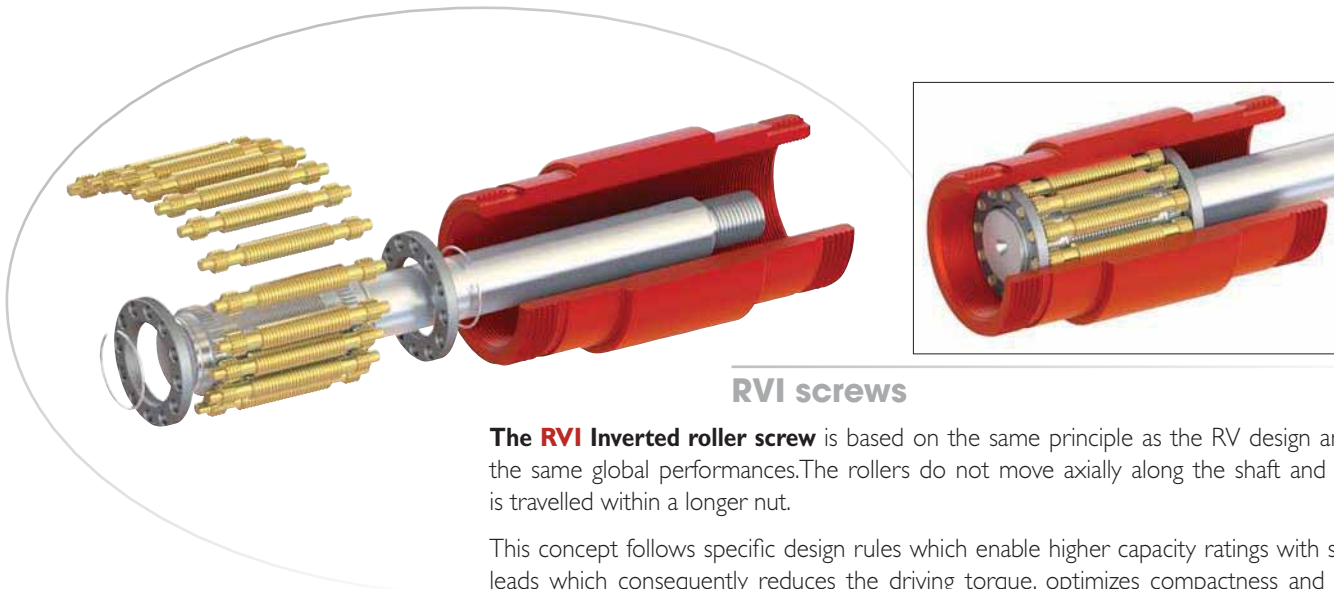

RVI screws

The **RVI Inverted roller screw** is based on the same principle as the RV design and has the same global performances. The rollers do not move axially along the shaft and stroke is travelled within a longer nut.

This concept follows specific design rules which enable higher capacity ratings with smaller leads which consequently reduces the driving torque, optimizes compactness and makes a direct guiding of the shaft possible.

The gears are designed between the rollers and the shaft and give a very smooth and stable synchronization of the rolling.



RVD screws

The **RVD roller screw** is ideally suited for high precision applications, when a high accuracy is needed. Its specific designed and adjusted components allow extremely thin leads of up to 0.05 mm even 0.02 mm. Available strokes are relatively smaller for this type of roller screw. RVD screw requires very specific tools and very high manufacturing accuracy to ensure an extreme a high quality standard.

Identification system

Example → **RV 2 1 0 / 30.5. R 3. 350/230 6YY ---**

Design **RV** = Satellite rollers screws
HRV = High capacity roller screws
RVR = Recirculating roller screws
RVI = Inverted roller screws
RVD = Differential roller screws

Nut types **1** = Single nut
2 = Split nut
3 = Double nut
4 = Preloaded nut with oversized rollers

Nut design **1** = Cylindrical nut
6 = Nut with flange at one end
7 = Nut with central flange
8 = Special nut design

Seal **0** = without wipers
1 = with wipers (possibility to order only one wiper)

Screw diameter d_0 in mm

Nominal lead P indication en mm

Thread direction **R** = right hand thread
L = left hand thread
B = 1 right hand thread and 1 left hand thread

Thread accuracy* **G1** = 6 $\mu\text{m}/300$ mm
G3 = 12 $\mu\text{m}/300$ mm
G5 = 23 $\mu\text{m}/300$ mm

Total screw shaft length / threaded length - in mm

This model number is defined by Rollvis

* refer to page 6 and ISO 3408-3 for thread accuracy details.

Accuracy

Satellite roller screws are divided into tolerance classes based as defined in **ISO 3408-3** (ball screws). The determining factor is the lead error V_{300p} referred to a thread length of 300 mm.

The table opposite shows the tolerance classes:

Tolerance class	V_{300p}
G1	6 $\mu\text{m}/300\text{ mm}$
G3	12 $\mu\text{m}/300\text{ mm}$
G5	23 $\mu\text{m}/300\text{ mm}$

Positioning satellite roller screws are supplied in tolerance classes **G1**, **G3** and **G5**. Higher accuracy classes can be manufactured on demand.

Lead accuracy symbols according to ISO 3408-3

- P → nominal lead
- e_0 → difference between required lead and nominal lead
- V_{300p} → difference between actual and nominal lead over 300 mm
- e_p → difference between actual and nominal lead over a length L_u
- V_{up} → travel variation over a length L_u
- $V_{2\pi p}$ → travel variation over one revolution
- L_u → effective travel

Lead error

The lead error e_p relative to effective travel L_u is calculated for the transport satellite roller screw by the following formula:

$$e_p = 2 \cdot \frac{L_u}{1000} \cdot V_{300p}$$

Lead errors e_p for positioning satellite roller screws are shown in the table opposite. For tolerance classes **G1** and **G3**, the lead and torque diagrams are supplied with the screws.

Lead is checked by a 3D measuring machine.

L_u		E_p in microns for tolerance class up to		
From	to	G1	G3	G5
	315 mm	6	12	23
315 mm	400 mm	7	13	25
400 mm	500 mm	8	15	27
500 mm	630 mm	9	16	30
630 mm	800 mm	10	18	35
800 mm	1000 mm	11	21	40
1000 mm	1250 mm	13	24	46
1250 mm	1600 mm	15	29	54
1600 mm	2000 mm			65
2000 mm	2500 mm			77
2500 mm	3150 mm			93

Efficiency

The power effectiveness of the roller screw is defined by the efficiency. It represents the thermal power dissipated at the various contact interfaces. This efficiency is of importance for motor torque calculation. Thus efficiency is essentially determined by the thread's geometry of the components, which will generate the sliding level. Lubrication, speed, level of load, surface finishing, etc... will also have an impact on the efficiency. There are two different values of efficiency depending on how the screw is used, in a direct or indirect mode:

- Direct efficiency η_1 corresponds to the efficiency of the mechanism when the rotation is converted into a translation motion.
- Indirect efficiency η_2 corresponds to the efficiency of the mechanism when a translation motion is converted into a rotation.

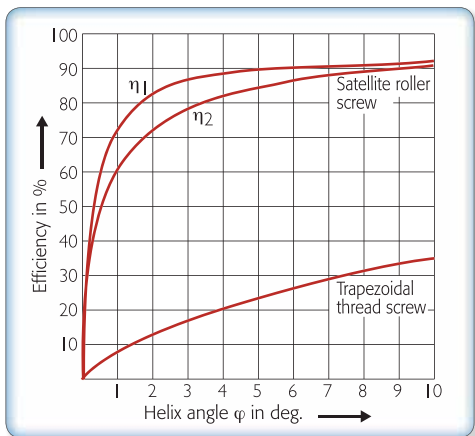

Rollvis satellite roller screws achieve high rates of mechanical efficiency. The figure shows efficiency rates η_1 and η_2 as a function of the helix angle. The efficiency of a trapezoidal thread screw (sliding screws) is shown for comparison. Satellite roller screws, unlike friction screws, are not self-locking.

Nut geometry and shape

Single nuts have low axial backlash. This version can also be manufactured with zero backlash or even with a light preload. The split cylindrical nut is preloaded by clamping the two halves of the nut in a housing. A precision spacer ring is mounted between the two halves to maintain the required level of preloading. Split nuts with a flange at one end have a spacer ring designed to hold the halves apart. The halves are aligned by a parallel key. Double nuts are preloaded in the same way as split nuts. Cylindrical nut types and central flanged ones are then usually preloaded in compression whereas side flanged nuts are preloaded in tension.

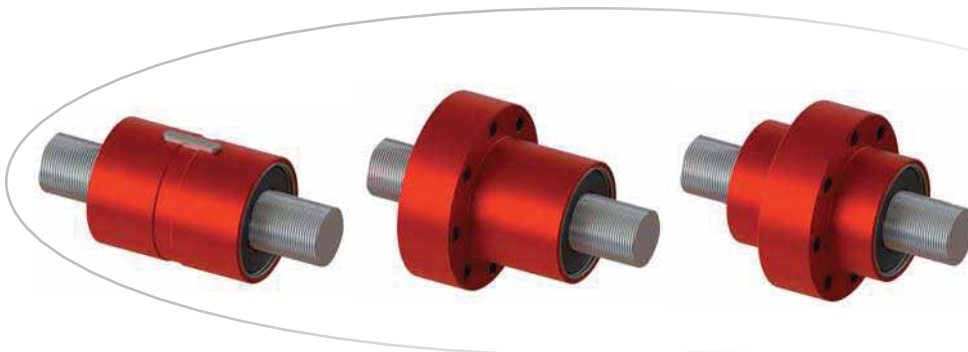

SINGLE NUTS:
Nuts in one piece with axial backlash
Wipers (on request)

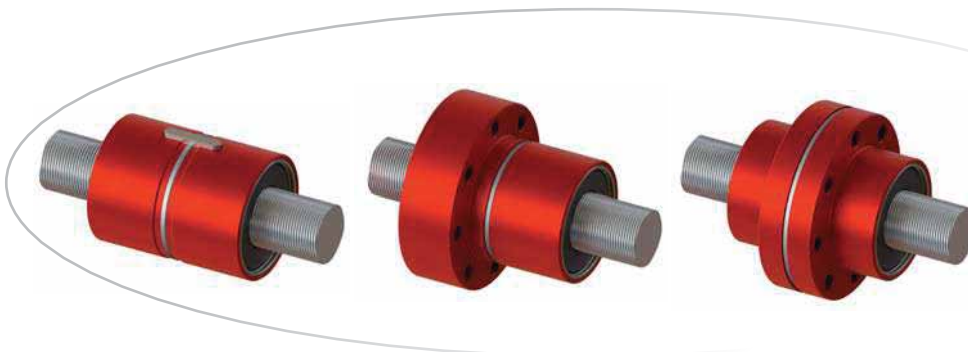

SPLIT NUTS:
Nuts in two pieces, preloaded, without backlash
Same dimensions as single nuts
Reduced load capacities
Wipers (on request)

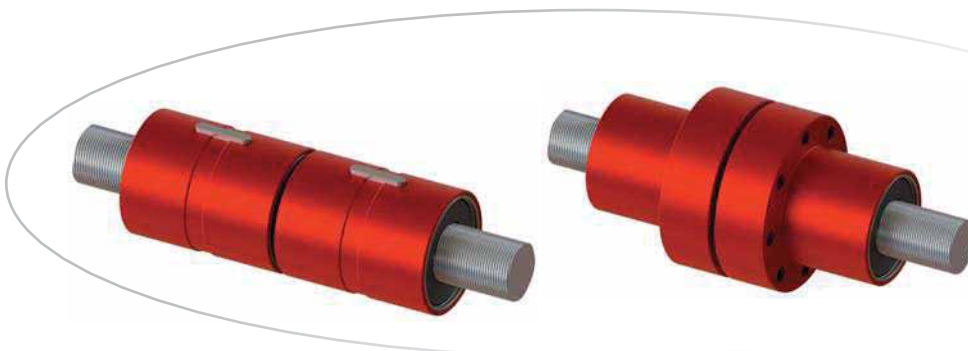

DOUBLE NUTS:
Two single nuts, preloaded, without backlash
Same load capacities as single nuts
About twice as long as single nuts
Wipers (on request)

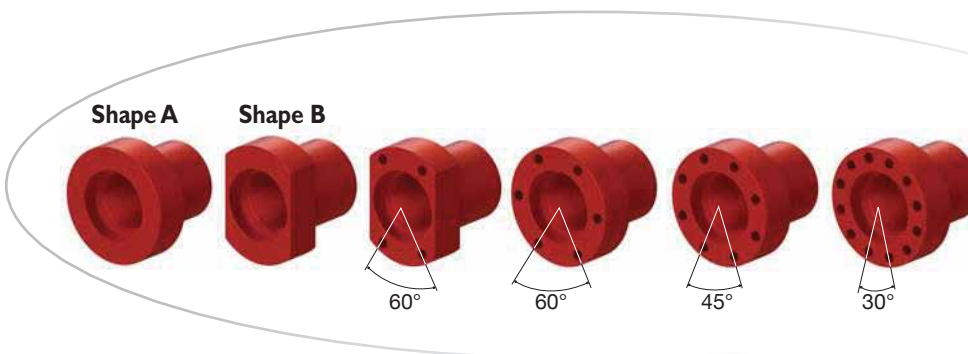

FLANGE SHAPES
Examples of typical flange shapes

Nut's geometry can be customised as per customer's specific needs.

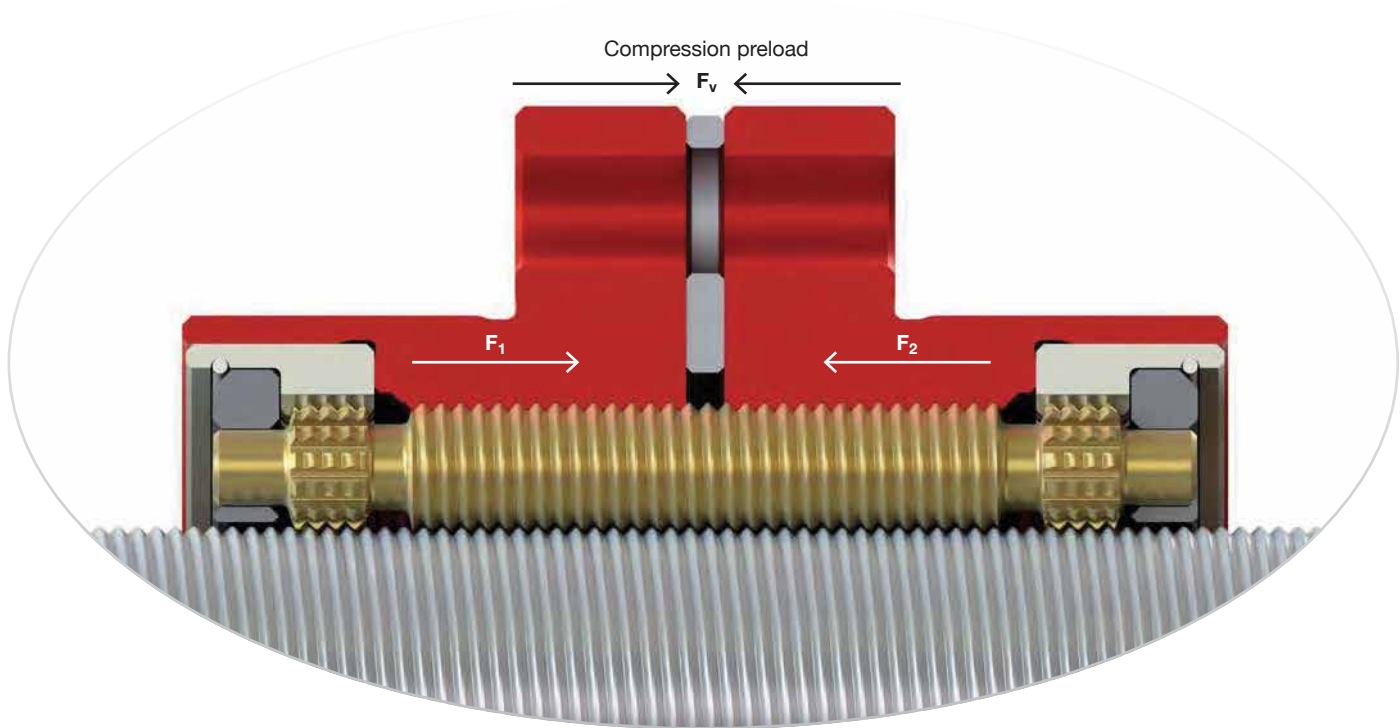

Preloaded nuts are used to eliminate backlash and increase rigidity.

Preload level should be carefully calculated to achieve the highest stiffness while keeping efficiency high and life the longest. (see figure above).

When considering preloaded nuts, the calculation of the equivalent mean load has to take into account the preload level F_v in case some preload is still active when the screw is exposed to external loads ($F_1 \dots F_n$). This may yield to new individual loads ($F_{1v} \dots F_{nv}$).

When no backlash is required for all operating loads, the preload F_v must be selected according to the maximum load F_{max} .

$$F_v = \frac{F_{max}}{2,83} \text{ [N]}$$

If a satellite roller screw only needs to be backlash-free for a specific load, preload F_v should be selected according to the corresponding load F_n .

$$F_v = \frac{F_n}{2,83} \text{ [N]}$$

Recommended nominal preload is otherwise defined in the product table pages of this catalog (for preloaded split nuts or single nuts).

Resulting load depending on preload F_v

An axial load on a preloaded nut system increases the load of one of the halves and relieves the other from the preloading force. The resulting load can be estimated by the following equations:

Loaded half of nut:

$$F_{nv(1)} = F_v + 0,65 \cdot F_n \text{ [N] si } F_n < 2,83 \cdot F_v \text{ [N]}$$

$$F_{nv(1)} = F_n \text{ [N] si } F_n \geq 2,83 \cdot F_v \text{ [N]}$$

Relieved half of nut:

$$F_{nv(2)} = F_v - 0,35 \cdot F_n \text{ [N] si } F_n < 2,83 \cdot F_v \text{ [N]}$$

$$F_{nv(2)} = 0 \text{ [N] si } F_n \geq 2,83 \cdot F_v \text{ [N]}$$

$F_1 \dots F_n$	[N]	: individual loads
F_v	[N]	: preload force
F_{nv}	[N]	: load resulting from the individual load and preload
F_{ma}	[N]	: equivalent mean load taking into account preload

Preloading examples

Preloading with rigid spacer (thickness calibrated by Rollvis SA)

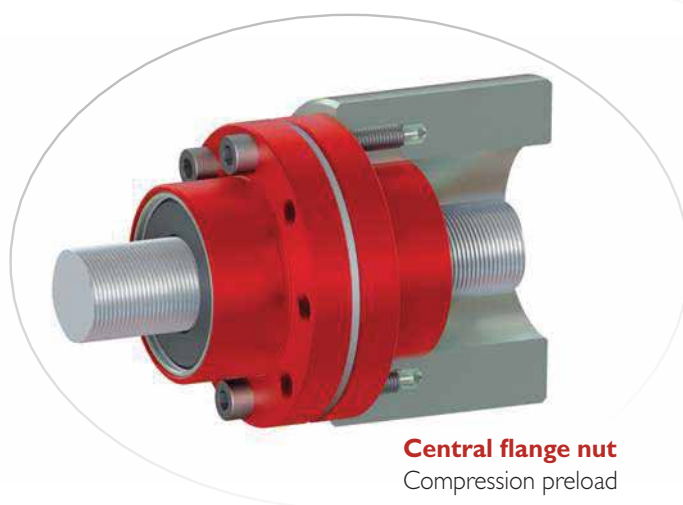
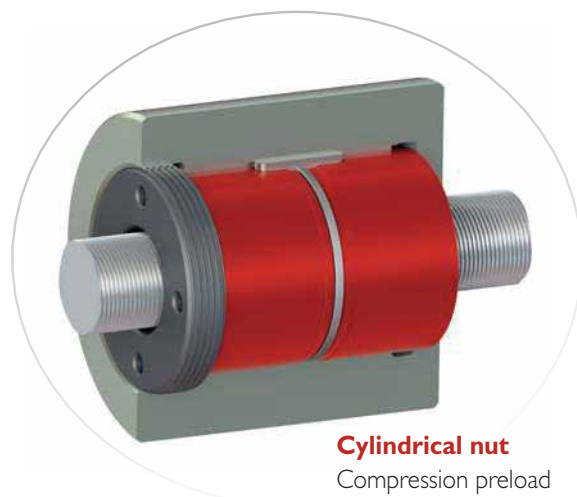
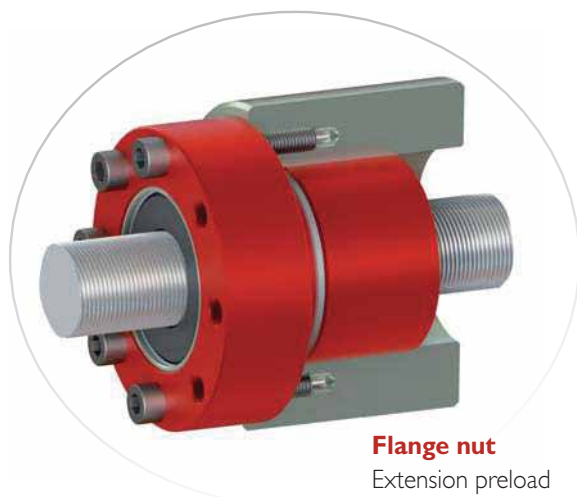

Preloading with elastic washers

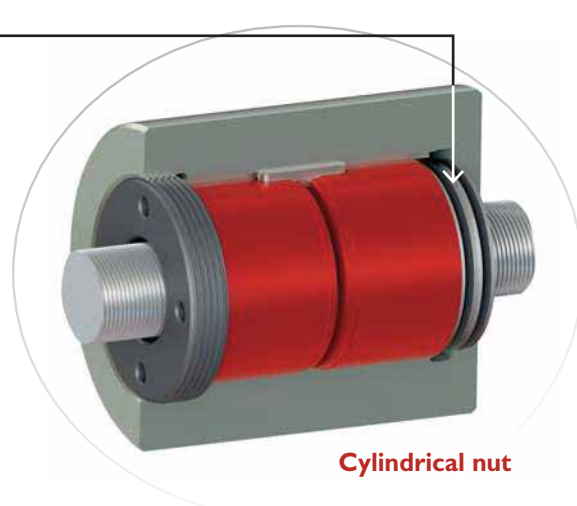
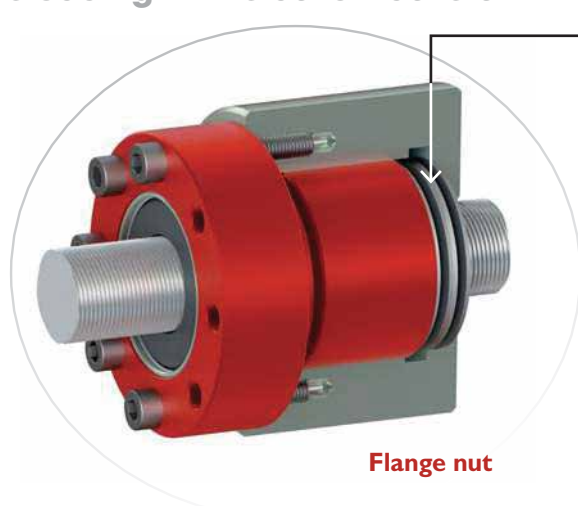

Elastic preload makes it easier to calibrate the level. However this type of preload gives an asymmetrical behaviour depending on the direction of the external load (whether path goes through the spring washer or not). Consult Rollvis for more details.

Preloading with oversized rollers

No change compared to regular single nuts for the mounting. The preload is set internally at the factory and is independent from external tightening.

Mean speed and equivalent mean load



For variable speed and load, lifespan should be calculated with mean values n_m et F_m .

For variable speed and constant load with speed n , the mean speed n_m is used (figure below).

$$n_m = \frac{q_1}{100} \cdot n_1 + \frac{q_2}{100} \cdot n_2 + \dots [\text{min}^{-1}]$$



The mean load is actually an equivalent cubic mean load. For a variable load at constant speed, the mean load F_m is used (figure below).

$$F_m = \sqrt[3]{F_1^3 \cdot \frac{q_1}{100} + F_2^3 \cdot \frac{q_2}{100} + \dots} [\text{N}]$$

For a variable load at variable speed, the mean load F_m is used.

$$F_m = \sqrt[3]{F_1^3 \cdot \frac{q_1}{100} \cdot \frac{n_1}{n_m} + F_2^3 \cdot \frac{q_2}{100} \cdot \frac{n_2}{n_m} + \dots} [\text{N}]$$



← For a variable linear load at constant speed, the mean load F_m is used (figure below).

$$F_m = \frac{F_{\min} + 2 \cdot F_{\max}}{3} [\text{N}]$$

n_m	[min^{-1}]	: mean speed
$n_1 \dots n_n$	[min^{-1}]	: individual speeds
$q_1 \dots q_n$	[%]	: time percentage
F_m	[N]	: mean load
$F ; F_1 \dots F_n ; F_{\min} ; F_{\max}$	[N]	: actual forces

Nominal lifespan

The nominal lifespan L_{10} or L_h of a satellite roller screw corresponds to the possible achievable life considering rolling fatigue failure mode. It is evaluated with a 90% probability of survival.

If greater reliability is required, the nominal lifespan L_{10} or L_h must be multiplied by the reliability factor f_r (table opposite).

Reliability %	f_r
90	1
95	0,62
96	0,53
97	0,44
98	0,33
99	0,21

updated lifetime, respectively

$$L_n = L_{10} \cdot f_r \quad [\text{revolutions}]$$

$$L_{hn} = L_h \cdot f_r \quad [\text{h}]$$

Nominal lifespan of single nuts (with backlash or internal preload with oversized rollers)

The nominal lifespan of single nuts is calculated with the following formula:

$$L_{10} = \left(\frac{C}{F_m} \right)^3 \cdot 10^6 \quad [\text{revolutions}]$$

or

$$L_h = \frac{L_{10}}{n_m \cdot 60} \quad [\text{h}]$$

The required dynamic load capacity as a function of the expected life time, can be calculated as follow:

$$C = F_m \cdot \sqrt[3]{\frac{L_{10}}{10^6}} \quad [\text{N}]$$

The lifespan in actual machine hours L_{hN} can be calculated considering the ratio between the roller screw life and the utilisation factor of the screw in the machine.

$$L_{hN} = \frac{L_h}{f_N} \quad [\text{h}]$$

Nominal lifespan of preloaded nuts

For preloaded nuts, it is first necessary to calculate the lifespan of each half of the nut with the corresponding dynamic load capacity C and the mean axial load F_{ma} (including preload). The total lifespan L_{10} of the preloaded nut is obtained with the two lifespan values $L_{10(1)}$ and $L_{10(2)}$ (in revolutions).

$$L_{10(1)} = \left(\frac{C}{F_{ma(1)}} \right)^3 \cdot 10^6 \quad [\text{revolutions}]$$

$$L_{10(2)} = \left(\frac{C}{F_{ma(2)}} \right)^3 \cdot 10^6 \quad [\text{revolutions}]$$

$$L_{10} = \left(L_{10(1)}^{-10/9} + L_{10(2)}^{-10/9} \right)^{-9/10} \quad [\text{revolutions}]$$

L_n [revolutions] : modified lifespan (revolutions)
 L_{hn} [h] : modified lifespan (hours)
 L_{10} [revolutions] : nominal lifespan (revolutions)
 L_h [h] : nominal lifespan (hours)
 L_{hN} [h] : lifetime in actual hours
 f_r [-] : reliability factor

C [N] : dynamic load capacity
 F_m [N] : mean load (single nut with backlash)
 F_{ma} [N] : mean load (preloaded nut)
 n_m [min-1] : mean speed
 f_N [-] : utilisation factor

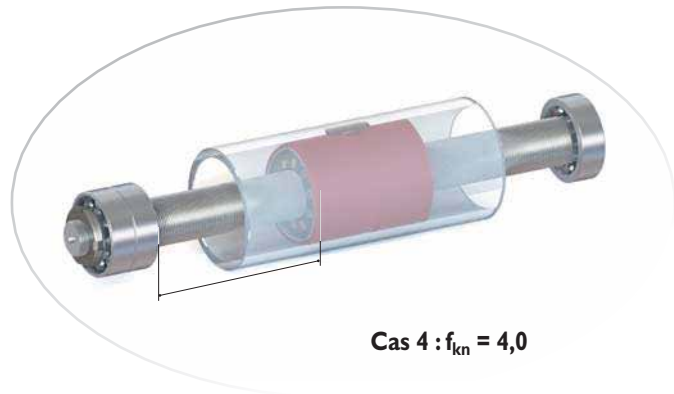
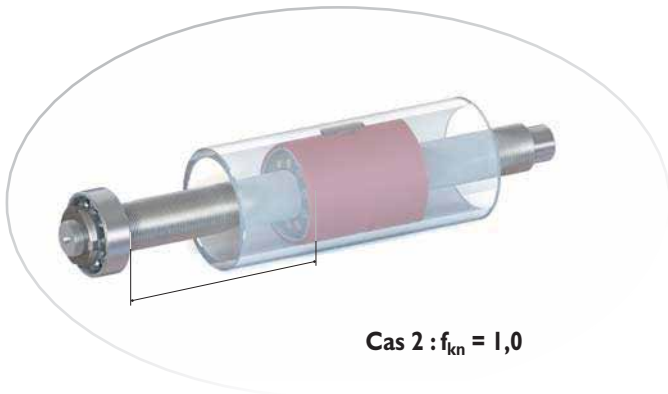
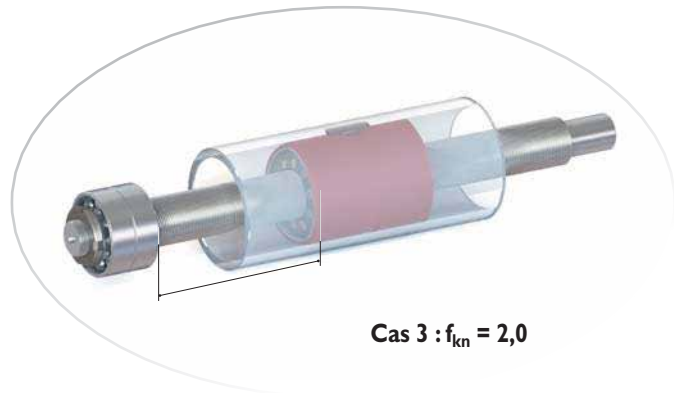
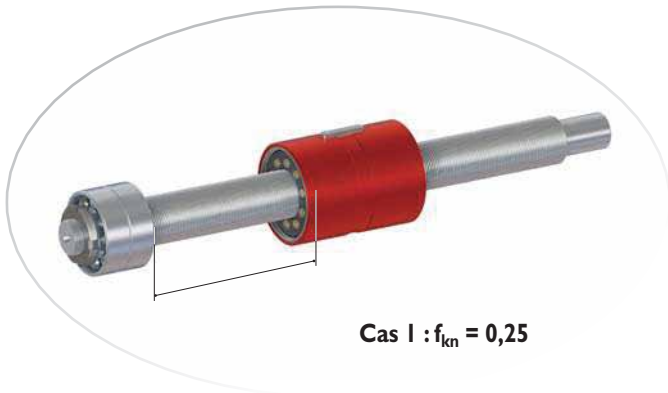

Satellite roller screw rigidity

The overall rigidity C_{ges} of a satellite roller screw is the combination of the following individual rigidity values:

C_{me} nut rigidity	C_L bearing rigidity
C_{Sp} screw rigidity	C_u rigidity of the surrounding construction

Permissible buckling force F_{knzul}

Permissible buckling force can be calculated with the following formula:

$$F_{knzul} = 0,8 \cdot 101,6 \cdot f_{kn} \cdot \frac{d_0^4}{L^2} \quad [\text{kN}]$$

0.8 corresponds to the safety factor : $= \frac{1}{1,25}$

Screw rigidity C_s

Screw rigidity C_s can be calculated with the following simplified formula:

$$C_s = 164 \cdot \frac{d_0^2}{L} \quad [\text{N}/\mu\text{m}]$$

F_v [N] : preloading force	f_m [-] : correction factor
F_n [N] : axial load	L [mm] : free screw length
C_{me} [N/ μm] : nut rigidity	d_0 [mm] : nominal diameter of screw
C_s [N/ μm] : screw rigidity	F_{knzul} [N] : permissible buckling force
f_k [N ^{2/3} / μm] : rigidity factor	f_{kn} [-] : correction factor for bearing type

Rotation speed

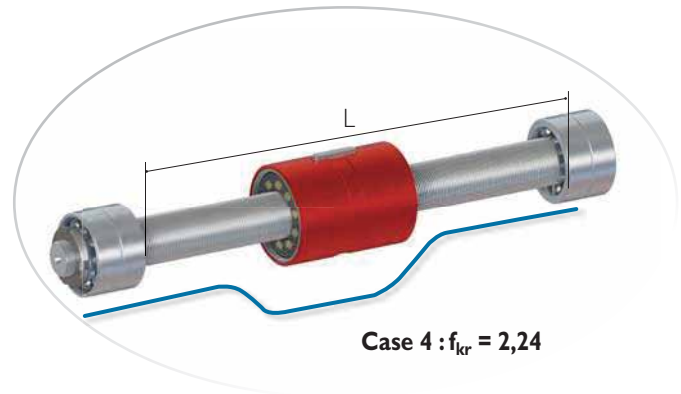
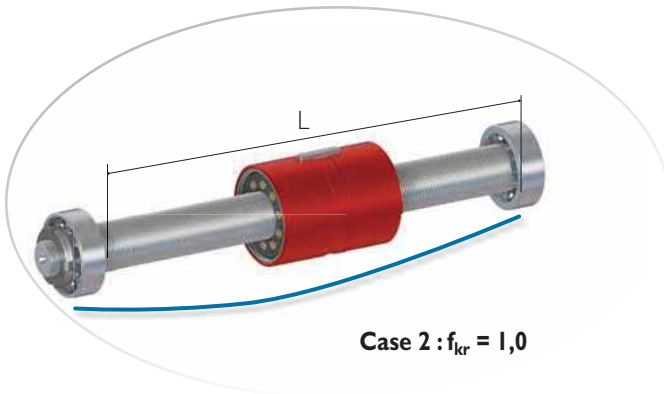
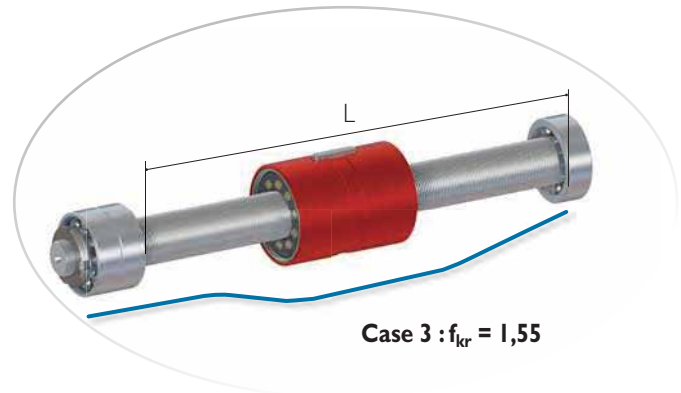
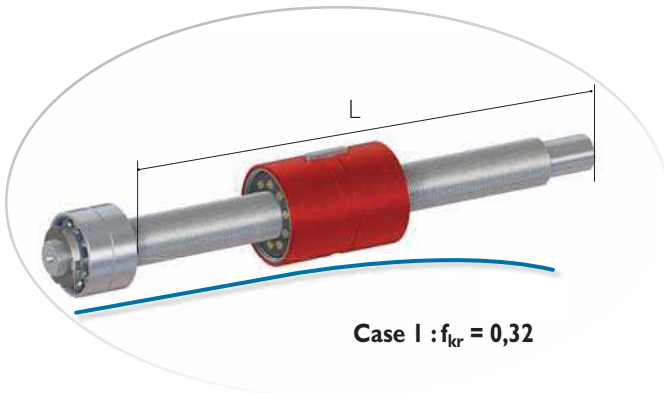

Permissible rotation speed and axial load

Satellite roller screws are restricted by the internal configuration of the nut, the bearings at the end of the screw and the critical number of revolutions n_{kr} due to flexural vibration.

The max permissible speed n correspond to a never exceed speed. It is also called the limit speed. The lowest speed between n and n_{kr} has to be considered as the recommended max speed.

- RV : $d_0 \cdot n \leq 160'000$
- RVR : $d_0 \cdot n \leq 32'000$
- RVI : $d_0 \cdot n \leq 160'000$
- RVD : $d_0 \cdot n \leq 100'000$

Critical speed n_{kr} with axial load $F_n = 0$

Critical speed corresponds to the first natural frequency in bending. It is mainly depending on the limit conditions, but can also be influenced by the axial load which can give some stiffness variations.

When the correct screw end bearings are selected, their maximum speed will have no effect on the desired speed. Bearings mount give to the screw shaft a mount correction factor f_{kr} , that is then used to calculate the corresponding critical speed. (above figures).

The calculation is based on the assumption that satellite roller screw nuts provide no guidance and the bearings at the screw end are considered rigid in the radial direction.

$$n_{kr} = 108 \cdot 10^3 \cdot d_0 \cdot \frac{1}{L^2} \quad [\text{min}^{-1}]$$

The permissible critical speed can be calculated by taking the bearing type into account:

$$n_{krzul} = 0,8 \cdot n_{kr} \cdot f_{kr} \quad [\text{min}^{-1}]$$

n [min ⁻¹]	: rotation speed	d_0 [mm]	: nominal diameter of screw
n_{kr} [min ⁻¹]	: critical rotation speed	f_{kr} [-]	: correction factor for bearing type
n_{krzul} [min ⁻¹]	: permissible critical rotation speed	0,8 [-]	: safety factor
L [mm]	: free screw length		

Driving torque

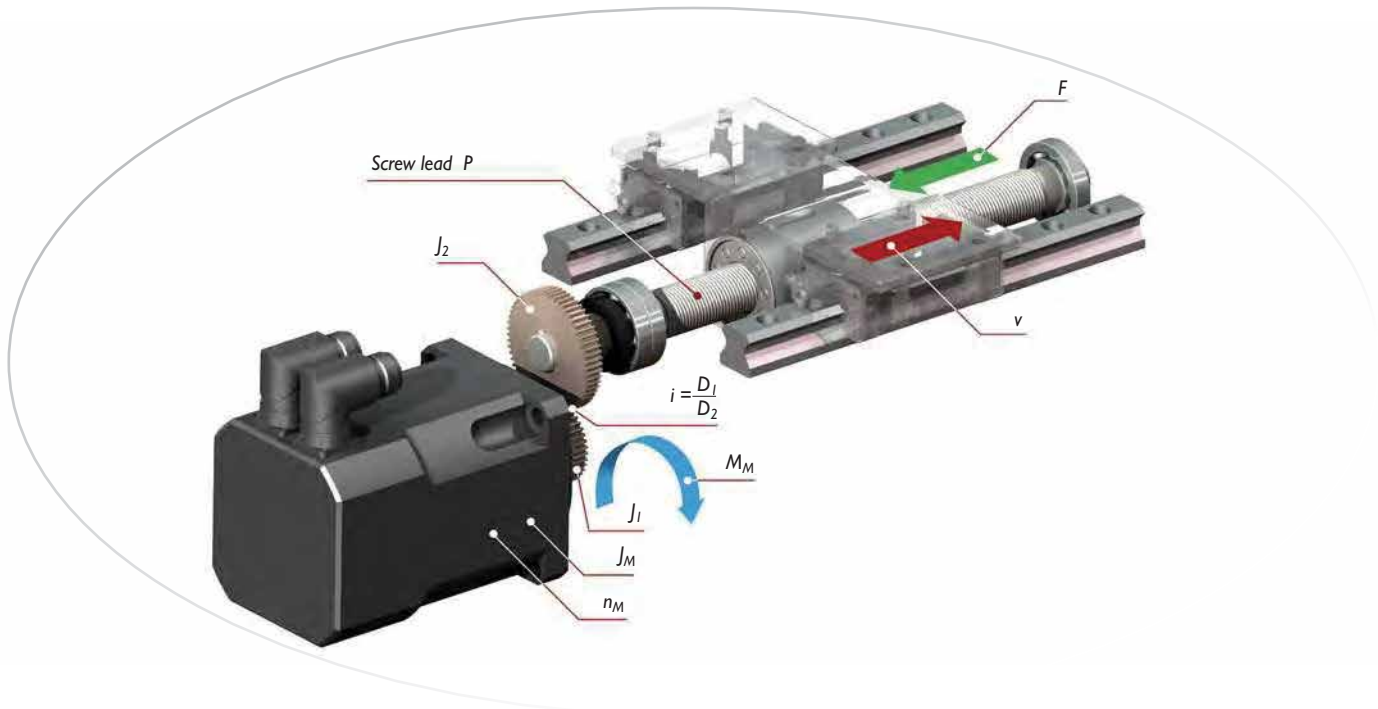

Driving torque

All the values for motor rating can be calculated with the formulas below.

Note that the load-free torque M_v must be taken into account for preloaded nuts (based on the preload force F_v).

For single nuts with backlash, the formula is: $M_v = 0$ [Nm]

Motor driving torque M_M at constant speed

Load-free torque

$$M_v = \frac{F_v \cdot P \cdot i \cdot c}{2000 \cdot \pi} \quad [\text{Nm}]$$

Direct torque («ascent load torque»)

$$M_{L1} = \frac{P \cdot i \cdot F}{2000 \cdot \pi \cdot \eta_1} \quad [\text{Nm}]$$

Indirect torque («Descent load torque»)

The frictional forces of the guide slideway must be taken into account in feed force F .
Corresponds to the braking torque

$$M_{L2} = \frac{P \cdot i \cdot F \cdot \eta_2}{2000 \cdot \pi} \quad [\text{Nm}]$$

Motor driving torque

If, as is possible in «Descent» mode, the motor driving torque is negative, the motor must have a brake.

$$M_M = (M_v + M_{L1,2} + M_R \cdot i) \quad [\text{Nm}]$$

Motor driving power

$$P_M = \frac{M_M \cdot n_M}{9,55} \quad [\text{W}]$$

d [mm] : external diameter of screw
 d_0 [mm] : nominal diameter of the screw
 d_b [mm] : diameter of the bore of the screw shaft
 d_2 [mm] : core diameter of screw
 P [mm] : screw lead
 L [mm] : length of satellite roller screw
 m_T [kg] : mass to move
 D_1 [mm] : diameter of driving wheel
 D_2 [mm] : diameter of driven wheel
 i [-] : reduction ratio
 F [N] : feed force

F_v [N] : preloading force
 F_a [N] : acceleration force
 M_v [Nm] : load-free torque
 M_{L1} [Nm] : «ascent» load torque at constant speed
 M_{L2} [Nm] : «descent» load torque at constant speed
 M_M [Nm] : motor driving torque
 M_{La} [Nm] : load torque on acceleration
 M_B [Nm] : acceleration torque
 M_{Ma} [Nm] : motor driving torque on acceleration
 M_R [Nm] : frictional torque of screw bearings

Motor driving torque M_{Ma} with acceleration

The rotary moment of inertia of screw J_R can be approximated with the formulae below.
Please contact Rollvis Engineering if you need exact figures of roller screw moment of inertia.

Load torque	$M_{La} = \frac{P \cdot i \cdot (F + F_a)}{2000 \cdot \pi \cdot \eta_1}$	[Nm]
Moment of inertia (translation)	$J_T = m_T \cdot \left(\frac{P}{2 \cdot \pi} \right)^2 \cdot 10^{-6}$	[kgm ²]
Screw moment of inertia (rotation)	$J_R = 7.66 \cdot L \cdot (d_0^4 - d_B^4) \cdot 10^{-13}$	[kgm ²] (for steel)
Sum of reduced moments of inertia	$J = J_M + J_1 + i^2 (J_R + J_T + J_2)$	[kgm ²]
Motor speed	$n_M = \frac{v \cdot 6 \cdot 10^4}{P \cdot i}$	[Min ⁻¹]
Acceleration torque $M_B = f(n_M)$	$M_B = \frac{n_M \cdot J}{9.55 \cdot t_B \cdot \eta}$	[Nm]
Acceleration torque $M_B = f(s_B)$	$M_B = \frac{4 \cdot \pi \cdot s_B \cdot J}{P \cdot i \cdot t_B^2 \cdot \eta}$	[Nm]
Acceleration time $t_B = f(n_M)$	$t_B = \frac{n_M \cdot J}{9.55 \cdot M_B \cdot \eta}$	[s]
Acceleration time $t_B = f(s_B)$	$t_B = \sqrt{\frac{4 \cdot \pi \cdot s_B \cdot J}{P \cdot i \cdot M_B \cdot \eta}}$	[s]
Rotation speed reached after acceleration	$n_M = \frac{120 \cdot s_B}{P \cdot i \cdot t_B}$	[Min ⁻¹]
Linear stroke travelled during acceleration	$s_B = \frac{n_M \cdot t_B \cdot P \cdot i}{120}$	[mm]
Motor driving torque	$M_{Ma} = (M_v + M_{vR} + M_{vR} \cdot i + M_B)$	[Nm]
Motor driving power	$P_{Ma} = \frac{M_{Ma} \cdot n_M}{9.55}$	[W]

J_M [kgm²] : moment of inertia of motor

J_R [kgm²] : rotary moment of inertia of screw

J_T [kgm²] : translatory moment of inertia of screw

J [kgm²] : moment of inertia

J_1 [kgm²] : moment of inertia of driving wheel

J_2 [kgm²] : moment of inertia of driven wheel

P_M [W] : driving power of motor at constant speed

P_{Ma} [W] : driving power of motor on acceleration

s_B [mm] : acceleration path

t_B [s] : acceleration time

v [m/s] : speed rate

n_M [min⁻¹] : rotation speed of motor

η [-] : mechanical efficiency of gearing

η_1 [-] : mechanical efficiency of satellite roller screw
for « ascent » $\eta_1 = 0,71 \dots 0,89$

η_2 [-] : mechanical efficiency of satellite roller screw
for « descent » $\eta_2 = 0,61 \dots 0,85$

c [-] : coefficient of friction referred to preloading
 $c = 0,1 \dots 0,5$

(for efficiencies $\eta_1 + \eta_2$ see page 6)

Calculation example

Satellite roller screws RV 20 x 5

Nominal diameter : $d_0 = 20$ mm
 Lead : $P = 5$ mm
 Nut : split nut (EF), preloaded
 Mounting position : horizontal
 Load direction : both sides
 Rapid mode : one side, opposite to working load

N°	Operating mode	Time percentage q [%]	Rotation speed n [min ⁻¹]	Axial load F _n [N]
1	Peak load	q ₁ = 5	n ₁ = 15	F ₁ = 8300
2	Roughing feed	q ₂ = 40	n ₂ = 110	F ₂ = 4500
3	Finishing feed	q ₃ = 50	n ₃ = 70	F ₃ = 4200
4	Rapid	q ₄ = 5	n ₄ = 1700	F ₄ = 1150

Mean speed

$$n_m = \frac{5}{100} \cdot 15 + \frac{40}{100} \cdot 110 + \frac{50}{100} \cdot 70 + \frac{5}{100} \cdot 1700 = 165 \text{ min}^{-1}$$

Preloading

For instance, preload is 1484 kN for this nut.
 (This level of preload has been defined by Rollvis engineering department as a function of the application conditions)

$$F_v = \frac{4200}{2.83} = 1484 \text{ N}$$

Load on nut half 1

Nut half 1 is loaded in operating modes 1, 2 and 3.
 As F_1, F_2 and $F_3 \geq 2.83 F_v$;

$$F_{1v} = F_n \text{ et ainsi } \begin{matrix} F_{1v} = 8300 \text{ N} \\ F_{2v} = 4500 \text{ N} \\ F_{3v} = 4200 \text{ N} \end{matrix}$$

Nut half 1 is only partly loaded in operating mode 4.
 As $F_4 = 1150 \text{ N} < 2.83 F_v$;

$$F_{4v} = 1484 - 0.35 \cdot 1150 = 1082 \text{ N}$$

Load on nut half 2

Half nut 2 is loaded in operating mode 4.
 Half nut 2 is not loaded in operating modes 1, 2 and 3.

$$F_{1v} = F_{2v} = F_{3v} = 0$$

As $F_4 < 2.83 \cdot F_v$, on a :

$$F_{4v} = 1484 + 0.65 \cdot 1150 = 2232 \text{ N}$$

Charge Mean load

$$\text{Nut 1 } F_{ma(1)} = \sqrt[3]{8300^5 \cdot \frac{15}{165} \cdot \frac{5}{100} + 4500^5 \cdot \frac{110}{165} \cdot \frac{40}{100} + 4200^5 \cdot \frac{70}{165} \cdot \frac{50}{100} + 1082^5 \cdot \frac{1700}{165} \cdot \frac{5}{100}} = 3511 \text{ N}$$

$$\text{Nut 2 } F_{ma(2)} = \sqrt[3]{2232^5 \cdot \frac{1700}{165} \cdot \frac{5}{100}} = 1789 \text{ N}$$

Lifespan

Dynamic load capacity of a nut C = 23 400 N

$$\text{Half nut 1 } L_{10(1)} = \left(\frac{23400}{3511} \right)^3 \cdot 10^6 = 296 \cdot 10^6 \text{ revolutions}$$

$$\text{Half nut 2 } L_{10(2)} = \left(\frac{23400}{1789} \right)^3 \cdot 10^6 = 2237 \cdot 10^6 \text{ revolutions}$$

Total lifespan

$$L_{10} = [(296 \cdot 10^6)^{-10/9} + (2237 \cdot 10^6)^{-10/9}]^{-9/10}$$
$$L_{10} = 270 \cdot 10^6 \text{ revolutions}$$

Lifespan in hours (with utilisation factor $f_N = 0.6$)

$$L_{hN} = \frac{270 \cdot 10^6}{165 \cdot 0,6 \cdot 60} = 45\,450 \text{ h}$$

Satellite roller screw rigidity

Free length between fixed bearing and nut $l = 1000 \text{ mm}$
Nominal diameter of screw $d_1 = 20 \text{ mm}$

$$C_5 = 164 \cdot \frac{20^2}{1000} = 66 \text{ N}/\mu\text{m}$$

Bearing rigidity

$$C_1 = 850 \text{ N}/\mu\text{m} \text{ ("refer to bearing catalogs")}$$

Driving torque

Driving torque MM is calculated for the peak load of $F_1 = 8300 \text{ N}$.

The screw is directly driven by the motor ($i = 1$):

Load-free torque: $M_v = \frac{1484 \cdot 5 \cdot 1 \cdot 0,43}{2000 \cdot \pi} = 0,5 \text{ Nm}$

Load torque: $M_{L1} = \frac{5 \cdot 1 \cdot 8300}{2000 \cdot \pi \cdot 0,87} = 7,6 \text{ Nm}$

Frictional torque of bearings: $M_R = 0,2 \text{ Nm (admitted)}$

Peak driving torque of motor at constant speed: $M_{Mmax} = 0,5 + 7,6 + 0,2 = 8,3 \text{ Nm}$

Motor driving power reaches its peak in rapid mode with $F_4 = 1150 \text{ N}$.

Moment en Load torque: $M_{L4} = \frac{5 \cdot 1 \cdot 1150}{2000 \cdot \pi \cdot 0,87} = 1,05 \text{ Nm}$

Peak driving power of motor at constant speed: $P_{Mmax} = \frac{(1,05 + 0,5 + 0,2) \cdot 1700}{9,55} = 312 \text{ W}$

Lubricants used for satellite roller screws are generally the same as for ball bearings. Oil or grease can both be used, depending on the application conditions and how maintenance is managed. Without specific request from customer, Rollvis use its standard grease. As a function of customer's application, we are able to define and offer the most appropriate lubricant.

Oil lubrication

Circulating mineral oils with EP additives to enhance resistance to aging and corrosion in compliance with CL based on DIN 51517, part 2, are especially suitable for the lubrication of satellite roller screws. Speed, ambient temperature and operating temperature are determining factors in the choice of viscosity.

The amount of oil required depends on the screw diameter; the number of supporting rollers and the amount of heat to dissipate. 1 cm³/h (for small screw diameters) to 30 cm³/h (for large screw diameters) can be used as reference values. Rollvis Engineering can support to calculate the power to be dissipated by the screw and make recommendation on the flow of oil to cool down the screw.

The shortest possible lubrication intervals (...5 minutes) are recommended for high loads and longer intervals (5 minutes to 1 hr) for low loads. Automatic lubrication is recommended for high loads and speeds.

For immersion lubrication, the oil level should be such that the bottommost roller is completely submerged in the oil. The amount of oil and the oil-change intervals depend on the loading and installation.

The viscosity of the oil should be chosen to enable an adequate film of lubricant to form on the contact surfaces.

Figure a shows the operating viscosity \mathbf{V}_k to achieve for the mean speed of the satellite roller screw and screw diameter.

Viscosity \mathbf{V}_k ensures a state of lubrication to fulfil the nominal lifespan provided the lubrication system is free of foreign bodies.

Nominal viscosity can be calculated on the basis of viscosity \mathbf{V}_k with the viscosity-temperature diagram (diagram **V-t**, **figure b**) and the operating temperature. Nominal viscosity is the viscosity of oil at 40°C. Viscosity classes **ISO VG (DIN 51519)** are plotted in diagram **V-t**.

Figure a shows the nominal diameters of RV satellite roller screws. The diameters of RVR satellite roller screws are slightly different. The required operating viscosity values can be obtained by interpolation.

Intermediate values can be obtained from the steps. These must be rounded up to the nearest viscosity value.

The operating temperature must be known or estimated to calculate nominal viscosity. The operating temperature must be measured on the nut after stabilisation. A suitable oil can be found in oil suppliers' lists with the nominal viscosity at 40°C. In general, an operating temperature of 30°C* can be taken as a basis for selecting a lubricant.

Example: Satellite roller screw RV 39 x 10
Mean operating speed: $n_m = 1400 \text{ min}^{-1}$
Operating temperature (estimated): $t = 25 \text{ }^\circ\text{C}$

In **figure a**, for a number of revolutions $n_m = 1400 \text{ min}^{-1}$ and a nominal diameter of 39mm, the nominal viscosity is $\mathbf{V}_k = 33 \text{ mm}^2/\text{s}$.

After the nominal viscosity has been defined, we recommend to apply a viscosity factor that can be estimated as the function of the loading conditions (**Figure a**).

For instance if for this application the mean load is 56kN, then the ratio is about 30% which gives a factor of 3.

The corrected nominal viscosity is then 100 cst.

In diagram **V-t** (**figure b**), the 25°C temperature and 100 mm²/s viscosity lines intersect with line ISO VG 46. The oil to select must have at least this viscosity if operating temperature is stabilized at 25°C. Note that a higher viscosity would also be possible but we do not recommend to choose a lower one.

A suitable CLP (DIN 51517) or HLP (DIN 51525) oil can be selected from this class.

* In case operating conditions are not known, Rollvis recommends using an oil with about 150 cst viscosity at 40°C.

Grease lubrication

For satellite roller screw, grease is usually preferred as a lubricant. Grease with lithium, barium or calcium thickeners are preferred. The chosen grease must have a viscosity at least 100 to 150 cst at 40°C, grade II and with specific additives. Lubrication recommendation are different when an automatic lubrication system is used.

Lubrication intervals depend on the screw arrangement, size and operating conditions. Rollvis can provide recommendations for any type of application.

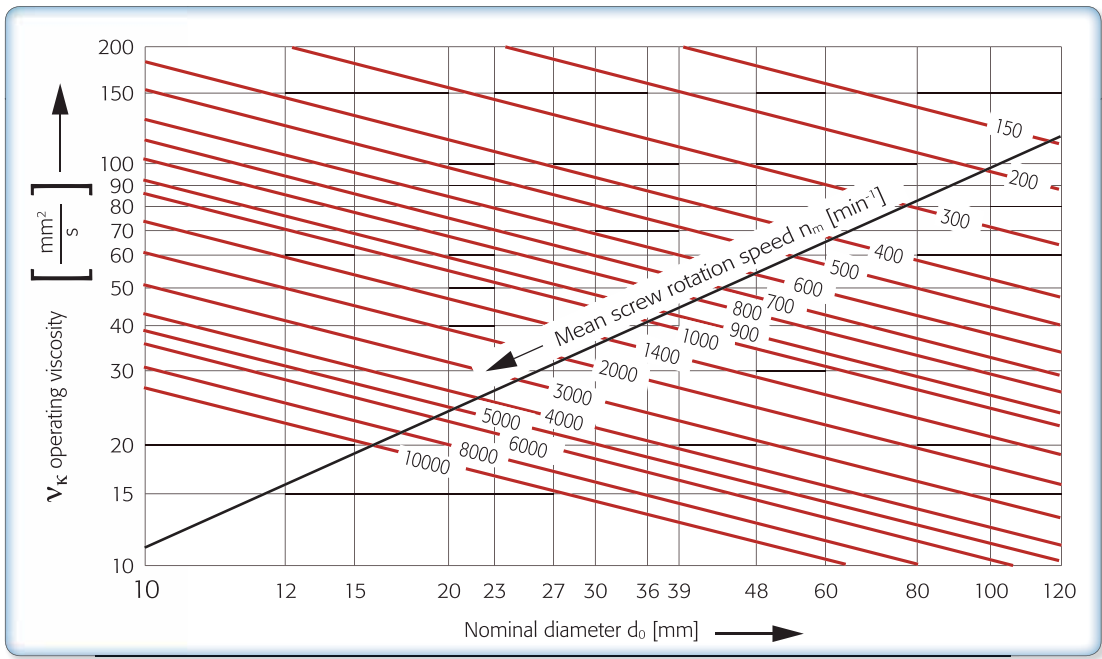

Figure a

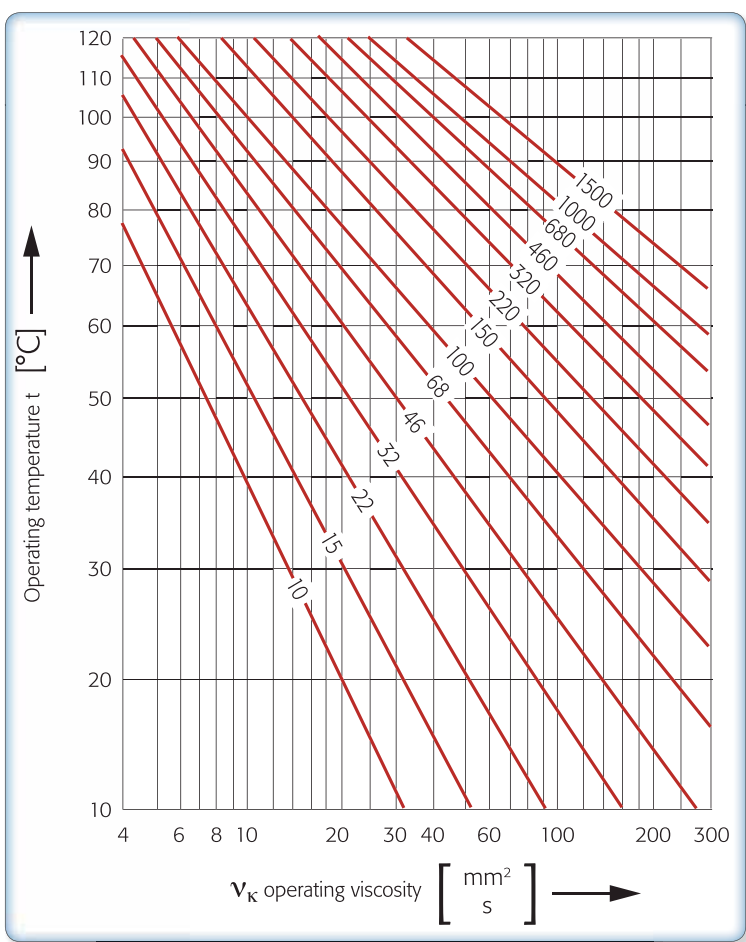

Figure b

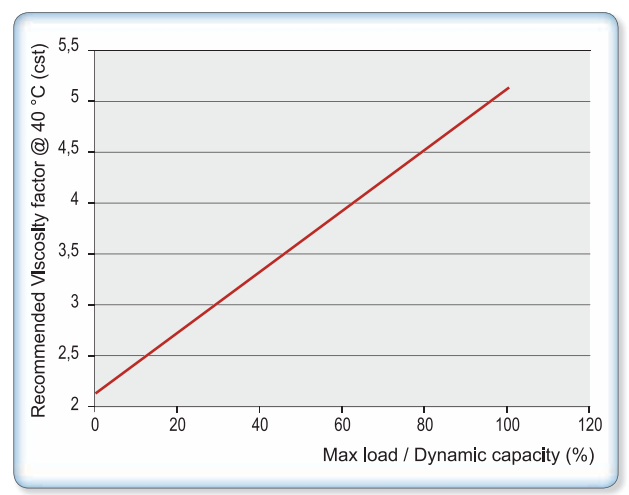

Figure a'

Handling advice

Assembly

If possible, the nut should not be removed from the screw shaft. However, should this be necessary, an assembly sleeve must be used. External diameter of assembly sleeve:

External diameter of the assembly sleeve $d_3 = d_2 + 0,05$
(d_2 = screw core diameter)

Screw assembly

Montage de la vis

The following points must be followed when assembling the screw:

- 1 • Align the screw and slide guideways axially parallel.
- 2 • Fix the nut in housing.
- 3 • Run the nut along the entire length of the thread and check the screw for ease of movement

CAUTION

RV screws always have a multiple-start thread. If the friction torque is slightly different after the nut is reassembled, the nut can be taken off again and reinstalled on the next thread start until friction torque is back to the original level !

Handling

Please heed strictly the following instructions to ensure optimal an operation and a long lifetime of the satellite roller screw.

Please, feel free to contact Rollvis for more **information or if you have any question.**

Lubrication



Satellite roller screws are greased prior to shipment (unless oil lubrication is requested).

Do not remove this grease. **Only use this type of grease for relubrication.**

Transport



Handle screws with care: do not let boxes or crates drop. Lift and handle so that the thread does not get damaged.

Installation



Do not remove the nut from the shaft (or only with an assembly sleeve). Carefully align satellite roller screws parallel to the guideways.

Alignment errors may generate side loads, create additional friction or noise and may damage the screw.

Storage









Only remove satellite roller screws from their original packing just before installation.

Bending



Design and installation must prevent radial forces or tilting moments on the nut.

	pages		
RV Screws	from 22 to 39		RV Range →
HRV Screws	from 40 to 45		HRV Range →
RVI Screws	from 46 to 51		RVI Range →
RVR Screws	from 52 to 57		RVR Range →
RVD Screws	from 58 to 63		RVD Range →
Bearing units for roller screws BU	from 64 to 68		Bearing units BU →

Preferred range



RV Range – Table of the standard available dimensions

Screw diameter (D)	Number of starts (N)	Lead (P)																			
		1	2	3	4	5	6	8	10	12	15	18	20	24	25	30	35	36	40	42	50
3,5	3	X	X																		
5	3	X	X	X																	
7	4	X	X	X	X																
8	4	X	X	X	X																
10	4	X																			
10	5		X	X	X																
12	4	X																			
12	5		X	X	X	X	X	X													
15	5		X	X	X	X	X	X													
18	5		X	X	X	X	X	X	X												
20	5		X	X	X	X	X	X	X	X											
21	5		X	X	X	X	X	X	X	X											
23	5		X	X	X	X	X	X	X	X											
25	6			X						X											
25	5		X		X	X	X	X	X	X	X										
27	5		X		X	X	X	X	X	X	X	X									
30	5		X		X	X	X	X	X	X	X	X	X								
36	6				X					X				X							
36	5		X		X	X	X	X	X	X	X	X	X	X							
39	5		X		X	X	X	X	X	X	X	X	X	X	X						
44	6				X					X				X							
48	6				X	X	X	X	X	X	X	X	X	X	X						
48	5				X					X				X							
51	5				X					X				X							
56	6				X					X				X							X
60	6				X					X				X							X
60	5				X					X				X							X
64	6				X					X				X							X
70	6				X					X				X							X
75	5				X					X				X							X
80	6				X					X				X							X
87	5				X					X				X							X
92	6				X					X				X							X
100	6				X					X				X							X
100	5				X					X				X							X
120	6				X					X				X							X
120	5				X					X				X							X

X N = 3
 X N = 4
 X N = 5
 X N = 6



RV 12 x 8



RV 30 x 30



RV 39 x 10

Dynamic capacities (Ca) diagram for roller screws as a function of the standard dimensions for standard RV and HRV roller screws range

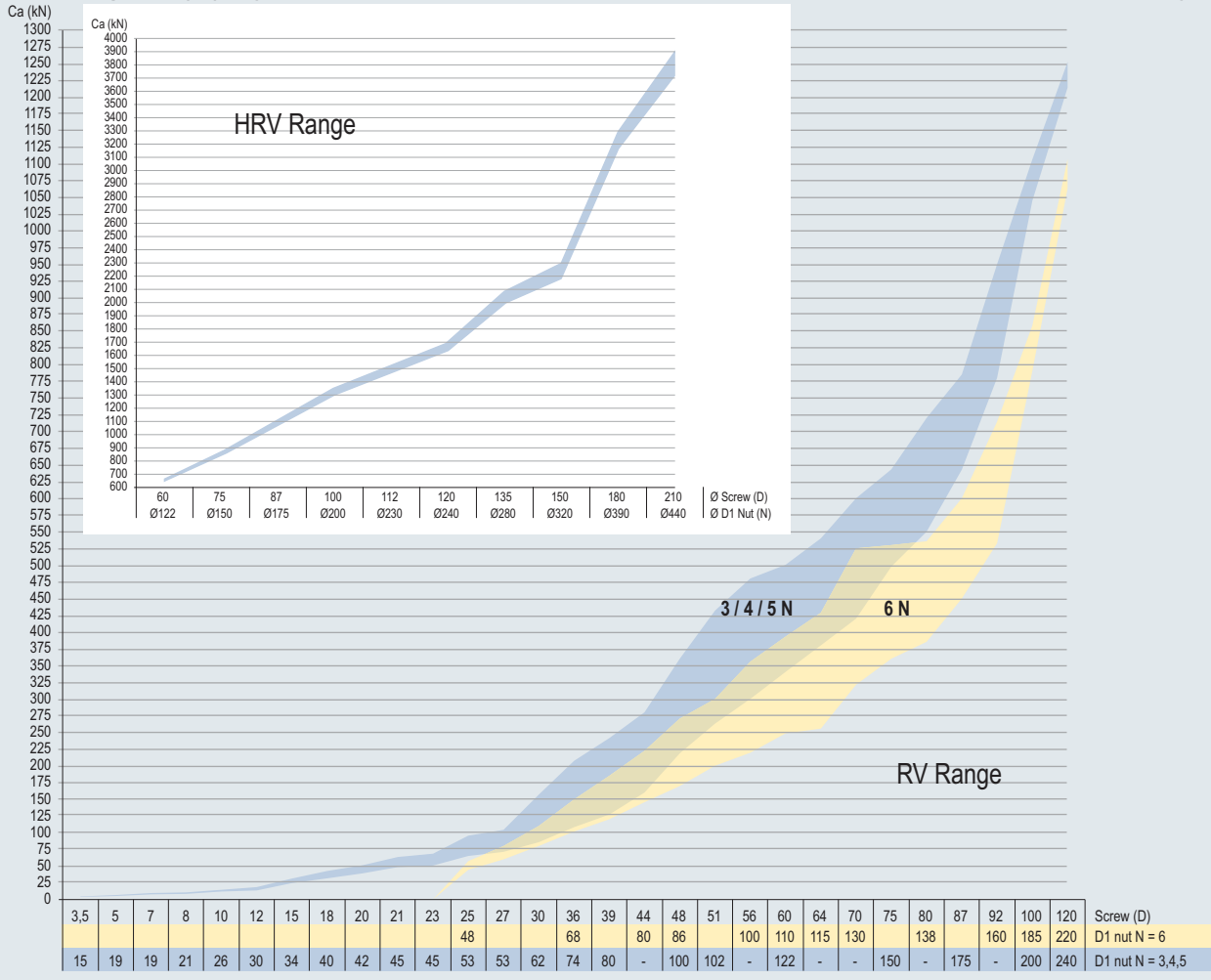



Dimensions	pages
● RV 3,5 / 5 / 7 / 8 / 10 / 12 / 15	24 et 25
● RV 18 / 20 / 21 / 23	26 et 27
● RV 25 / 27 / 30	28 et 29
● RV 36 / 39 / 44	30 et 31
● RV 48 / 51 / 56	32 et 33
● RV 60 / 64 / 70	34 et 35
● RV 75 / 80 / 87 / 92	36 et 37
● RV 100 / 120	38 et 39

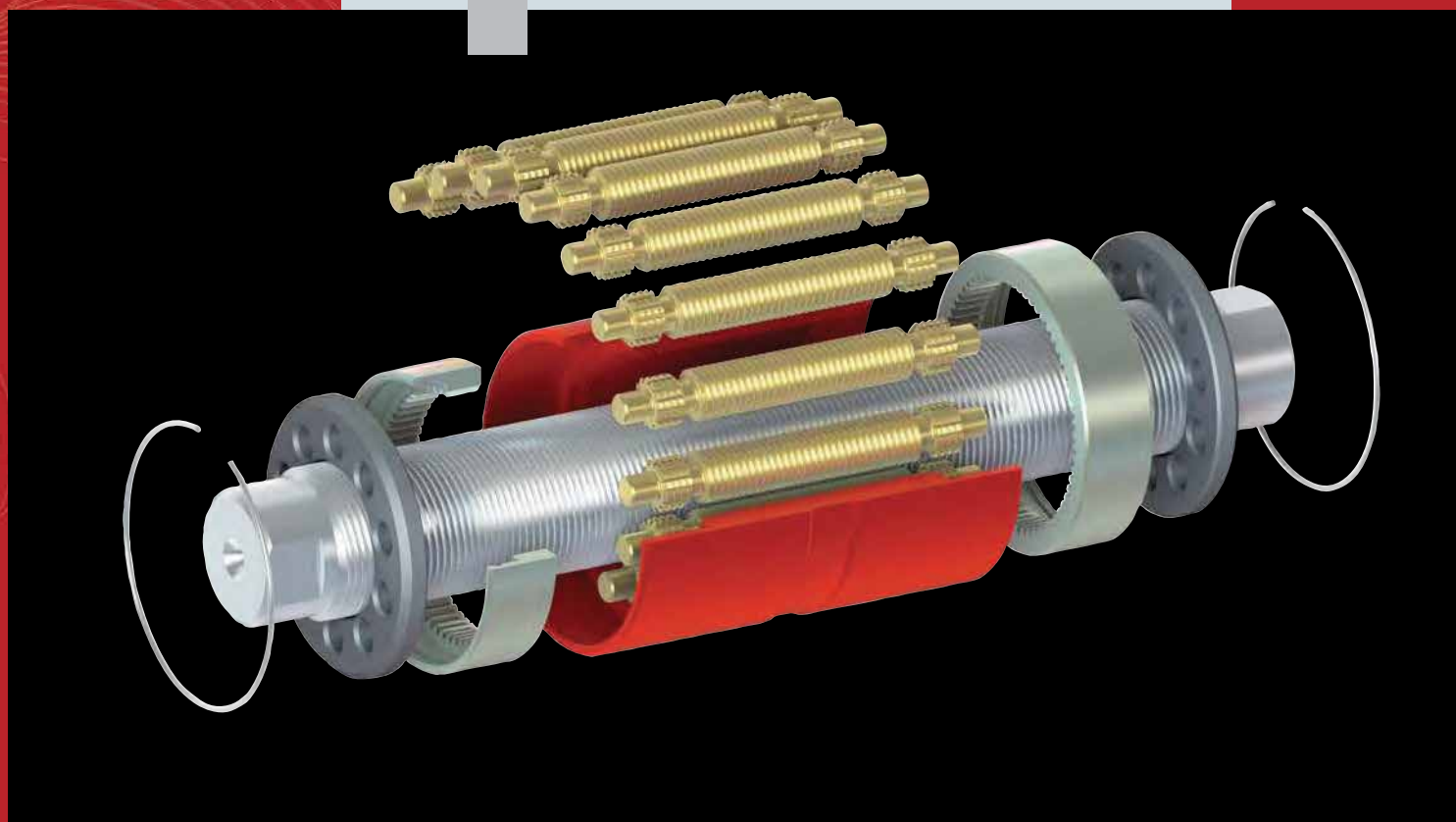

RV Range - Satellite roller screws

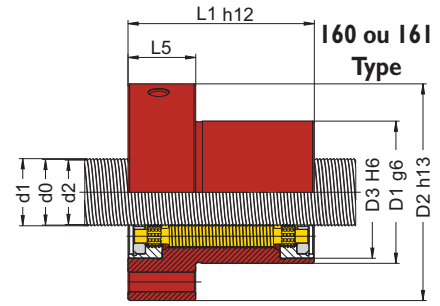
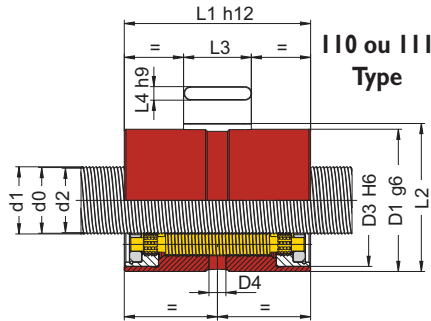

Types		TECHNICAL CHARACTERISTICS																		
		SINGLE NUT							DOUBLE NUT					SPLIT NUT						DIRECT efficiency
D x P	N	Helix angle [°]	Ca [kN]	C0a [kN]	Fk [N2/3µm]	Max axial backlash *	Ca [kN]	C0a [kN]	Fk [N2/3µm]	Fv [N]	Mv [Nm]	Ca [kN]	C0a [kN]	Fk [N2/3µm]	Fv [N]	Mv [Nm]	DIRECT efficiency	INDIRECT efficiency		
RV	3,5 x	1	3	5,20	3,9	8,4	28,6	0,01	3,9	8,4	42,9	561	0,03	2,2	4,2	18,0	561	0,03	0,89	0,87
		2	10,31	4,6	8,5	20,2	0,02	4,6	8,5	30,3	252	0,03	2,5	4,2	12,7	252	0,03	0,88	0,86	
RV	5 x	1	3	4,05	5,2	11,7	33,0	0,02	5,2	11,7	49,5	679	0,04	2,9	5,9	20,8	679	0,04	0,88	0,86
		2	8,05	6,2	11,8	23,0	0,02	6,2	11,8	34,5	390	0,04	3,4	5,9	14,5	390	0,04	0,89	0,87	
		3	11,98	6,7	11,9	18,8	0,02	6,7	11,9	28,2	193	0,04	3,7	6,0	11,8	193	0,04	0,86	0,83	
RV	7 x	1	4	2,60	7,7	18,7	50,6	0,02	7,7	18,7	76,0	519	0,04	4,2	9,3	31,9	519	0,04	0,84	0,81
		2	5,20	8,3	16,4	32,3	0,03	8,3	16,4	48,4	377	0,04	4,6	8,2	20,3	377	0,04	0,89	0,87	
		3	7,77	9,0	16,2	26,2	0,04	9,0	16,2	39,3	260	0,04	4,9	8,1	16,5	260	0,04	0,89	0,88	
		4	10,31	9,7	16,6	22,9	0,05	9,7	16,6	34,3	168	0,04	5,3	8,3	14,4	168	0,04	0,88	0,86	
RV	8 x	1	4	2,28	8,4	20,2	52,3	0,02	8,4	20,2	78,4	581	0,05	4,6	10,1	32,9	581	0,05	0,83	0,79
		2	4,55	10,0	20,3	36,3	0,02	10,0	20,3	54,5	453	0,05	5,5	10,2	22,9	453	0,05	0,88	0,87	
		3	6,81	9,9	17,5	26,7	0,04	9,9	17,5	40,1	329	0,05	5,4	8,8	16,8	329	0,05	0,89	0,88	
		4	9,04	10,7	18,0	23,4	0,05	10,7	18,0	35,1	232	0,05	5,9	9,0	14,8	232	0,05	0,88	0,87	
RV	10 x	1	4	1,82	12,0	22,8	54,7	0,02	12,0	22,8	82,1	587	0,06	6,6	11,4	34,5	587	0,06	0,80	0,75
		2	3,47	13,3	24,8	46,4	0,02	13,3	24,8	69,6	475	0,06	7,3	12,4	29,2	475	0,06	0,87	0,85	
		3	5,20	14,3	24,1	36,9	0,03	14,3	24,1	55,4	378	0,06	7,9	12,0	23,3	378	0,06	0,89	0,87	
		4	6,91	14,6	22,6	30,4	0,04	14,6	22,6	45,6	297	0,06	8,0	11,3	19,1	297	0,06	0,89	0,88	
RV	12 x	1	4	1,52	13,6	25,0	56,4	0,02	13,6	25,0	84,6	673	0,08	7,5	12,5	35,5	673	0,08	0,78	0,71
		2	3,04	14,6	26,9	47,6	0,02	14,6	26,9	71,3	578	0,08	8,0	13,4	30,0	578	0,08	0,86	0,83	
		3	4,55	15,7	26,1	37,9	0,02	15,7	26,1	56,8	485	0,08	8,7	13,0	23,8	485	0,08	0,88	0,87	
		4	6,06	17,2	27,2	33,3	0,03	17,2	27,2	50,0	392	0,08	9,5	13,6	21,0	392	0,08	0,89	0,88	
		5	7,55	18,1	27,3	29,8	0,05	18,1	27,3	44,7	313	0,08	9,9	13,6	18,8	313	0,08	0,89	0,88	
		6	9,04	18,4	26,5	26,7	0,05	18,4	26,5	40,1	246	0,08	10,1	13,2	16,8	246	0,08	0,88	0,87	
		8	11,98	18,6	24,9	22,0	0,05	18,6	24,9	33,1	146	0,08	10,2	12,5	13,9	146	0,08	0,86	0,83	
RV	15 x	2	5	2,43	24,6	55,4	66,7	0,02	24,6	55,4	100,1	617	0,10	13,6	27,7	42,0	617	0,10	0,84	0,80
		3	3,64	25,5	50,5	50,9	0,02	25,5	50,5	76,3	540	0,10	14,0	25,3	32,0	540	0,10	0,87	0,85	
		4	4,85	26,8	49,5	43,3	0,03	26,8	49,5	64,9	466	0,10	14,8	24,7	27,3	466	0,10	0,88	0,87	
		5	6,06	28,9	51,5	39,4	0,04	28,9	51,5	59,1	394	0,10	15,9	25,7	24,8	394	0,10	0,89	0,88	
		6	7,26	29,9	51,0	35,8	0,05	29,9	51,0	53,7	330	0,10	16,5	25,5	22,5	330	0,10	0,89	0,88	
		8	9,63	31,4	50,1	30,6	0,05	31,4	50,1	45,9	223	0,10	17,3	25,1	19,3	223	0,10	0,88	0,86	

* Axial backlash can be reduced on demand.

Terms used in tables	N Number of starts	F_k Rigidity factor
P Lead (travel per revolution)	Ca Dynamic load capacity	F_v Preloading force
D Reference diameter	C0a Static load capacity	M_v Preload torque

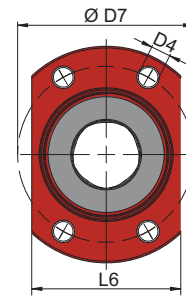
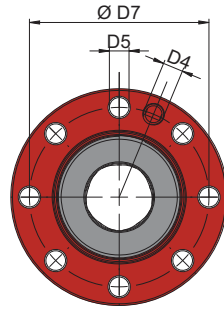
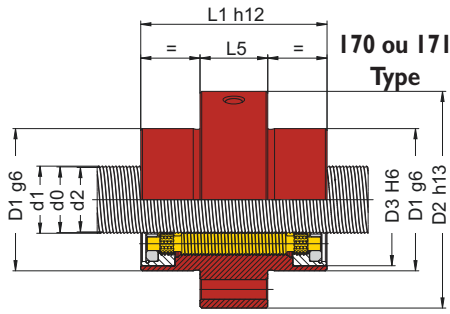

Types	SCREW										NUT								
	D x P	[mm]	[mm]	[mm]	[mm]	[mm]	[mm]	[mm]	[mm]	[mm]	Without wiper	With wipers	[mm]	[mm]	[mm]	[mm]	[mm]		
		Ø d1	Ø d0	Ø d2	Ø D1	Ø D2	Ø D3	D4	Ø D5	Ø D7	L1	L2	L3	L4	L5	L6			
RV	3,5 x	1	3,63	3,5	3,35	15	35	13,5	/	/	4,8	25	28	38	16	10	2	13	17
		2	3,75		3,20														
RV	5 x	1	4,63	4,5	4,35	19	39	17	3	/	4,8	29	30	40	20,3	10	3	13	21
		2	4,75		4,20														
		3	4,88		4,06														
RV	7 x	1	7,09	7	6,89	19	41	17	3	/	4,8	31	31	41	20,3	10	3	13	21
		2	7,19		6,78														
		3	7,28		6,67														
		4	7,38		6,56														
RV	8 x	1	8,09	8	7,89	21	41	19	5	M5	4,8	31	31	41	22,3	10	3	13	23
		2	8,19		7,78														
		3	8,28		7,67														
		4	8,38		7,56														
RV	10 x	1	10,09	10	9,89	26	48	24	5	M5	4,8	36	31	41	25,3	10	3	13	26
		2	10,65		10,32														
		3	10,73		10,23														
		4	10,80		10,14														
RV	12 x	1	12,09	12	11,89	30	50	28	5	M5	4,8	40	31	41	31,3	10	3	13	32
		2	12,15		11,82														
		3	12,23		11,73														
		4	12,30		11,64														
		5	12,38		11,56														
		6	12,45		11,47														
		8	12,60		11,29														
		RV	15 x		2														
3	15,23			14,73															
4	15,30			14,64															
5	15,38			14,56															
6	15,45			14,47															
8	15,60			14,29															

Terms used in tables
D Reference diameter **d0** Nominal diameter
P Lead (travel per revolution) **d1** External diameter **d2** Thread root diameter

RV Range - Satellite roller screws

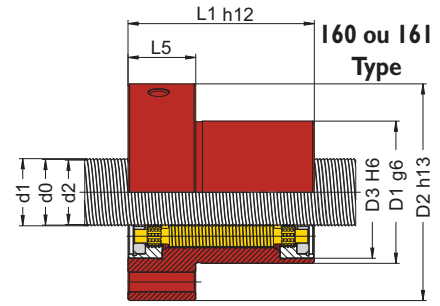
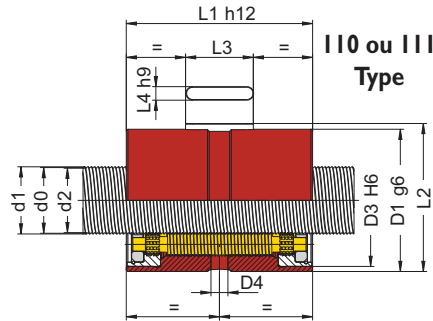

Types		TECHNICAL CHARACTERISTICS																		
		D x P	N	Helix angle [°]	SINGLE NUT				DOUBLE NUT					SPLIT NUT					DIRECT efficiency	INDIRECT efficiency
					Ca [kN]	C0a [kN]	Fk [N2/3µm]	Max axial backlash *	Ca [kN]	C0a [kN]	Fk [N2/3µm]	Fv [N]	Mv [Nm]	Ca [kN]	C0a [kN]	Fk [N2/3µm]	Fv [N]	Mv [Nm]		
RV	18 x	5	2	2,03	31,7	75,8	76,5	0,02	31,7	75,8	114,7	803	0,15	17,5	37,9	48,2	803	0,15	0,82	0,77
			3	3,04	35,0	76,1	61,8	0,02	35,0	76,1	92,7	722	0,15	19,3	38,0	38,9	722	0,15	0,86	0,83
			4	4,05	37,5	76,3	53,2	0,02	37,5	76,3	79,8	645	0,15	20,6	38,1	33,5	645	0,15	0,88	0,86
			5	5,05	39,0	74,9	46,9	0,03	39,0	74,9	70,4	564	0,15	21,5	37,4	29,6	564	0,15	0,89	0,87
			6	6,06	38,7	69,7	40,6	0,04	38,7	69,7	61,0	490	0,15	21,3	34,9	25,6	490	0,15	0,89	0,88
			8	8,05	40,2	67,2	34,5	0,05	40,2	67,2	51,7	361	0,15	40,2	33,6	21,7	361	0,15	0,89	0,87
			10	10,03	42,7	69,1	31,2	0,05	42,7	69,1	46,8	260	0,15	23,5	34,5	19,6	260	0,15	0,88	0,86
RV	20 x	5	2	1,87	39,1	102,1	87,8	0,02	39,1	102,1	131,7	1002	0,20	21,5	51,1	55,3	1002	0,20	0,81	0,76
			3	2,80	42,7	100,6	70,1	0,02	42,7	100,6	105,1	911	0,20	23,5	50,3	44,1	911	0,20	0,85	0,82
			4	3,74	45,7	100,8	60,4	0,02	45,7	100,8	90,6	821	0,20	25,2	50,4	38,1	821	0,20	0,87	0,85
			5	4,67	48,0	100,2	53,5	0,03	48,0	100,2	80,3	733	0,20	26,4	50,1	33,7	733	0,20	0,88	0,87
			6	5,59	50,3	101,3	49,0	0,04	50,3	101,3	73,5	645	0,20	27,7	50,7	30,9	645	0,20	0,89	0,88
			8	7,44	49,3	89,3	39,2	0,05	49,3	89,3	58,8	492	0,20	27,2	44,7	24,7	492	0,20	0,89	0,88
			10	9,27	51,2	88,1	34,7	0,05	51,2	88,1	52,1	364	0,20	28,2	44,1	21,9	364	0,20	0,88	0,87
RV	21 x	5	2	1,74	48,4	106,9	89,2	0,02	48,4	106,9	133,7	1175	0,25	26,7	53,4	56,2	1175	0,25	0,80	0,74
			3	2,60	52,9	105,3	70,9	0,02	52,9	105,3	106,4	1082	0,25	29,1	52,6	44,7	1082	0,25	0,84	0,81
			4	3,47	56,7	105,5	61,3	0,02	56,7	105,5	91,9	983	0,25	31,2	52,8	38,6	983	0,25	0,87	0,85
			5	4,33	59,4	104,8	54,2	0,03	59,4	104,8	81,3	886	0,25	32,7	52,4	34,2	886	0,25	0,88	0,86
			6	5,20	62,4	106,0	49,6	0,03	62,4	106,0	74,4	791	0,25	34,4	53,0	31,2	791	0,25	0,89	0,87
			8	6,91	61,2	93,5	39,7	0,04	61,2	93,5	59,6	619	0,25	33,7	46,7	25,0	619	0,25	0,89	0,88
			10	8,62	63,5	92,2	35,1	0,05	63,5	92,2	52,7	472	0,25	35,0	46,1	22,1	472	0,25	0,89	0,87
RV	23 x	5	2	1,62	50,8	111,4	90,4	0,02	50,8	111,4	135,6	1330	0,30	28,0	55,7	57,0	1330	0,30	0,79	0,73
			3	2,43	55,5	109,7	71,8	0,02	55,5	109,7	107,7	1230	0,30	30,6	54,8	45,2	1230	0,30	0,84	0,80
			4	3,24	59,5	109,9	62,1	0,02	59,5	109,9	93,1	1130	0,30	32,8	55,0	39,1	1130	0,30	0,86	0,84
			5	4,05	62,4	109,2	54,9	0,03	62,4	109,2	82,4	1028	0,30	34,4	54,6	34,6	1028	0,30	0,88	0,86
			6	4,85	65,5	110,5	50,2	0,03	65,5	110,5	75,3	928	0,30	36,1	55,3	31,6	928	0,30	0,88	0,87
			8	6,46	68,5	107,1	42,8	0,04	68,5	107,1	64,2	741	0,30	37,7	53,6	27,0	741	0,30	0,89	0,88
			10	8,05	66,8	96,1	35,6	0,05	66,8	96,1	53,4	580	0,30	36,8	48,1	22,4	580	0,30	0,89	0,87

* Axial backlash can be reduced on demand.

Terms used in tables	N Number of starts	F_k Rigidity factor
P Lead (travel per revolution)	Ca Dynamic load capacity	F_v Preloading force
D Reference diameter	C0a Static load capacity	M_v Preload torque

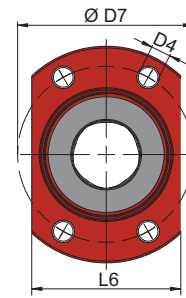
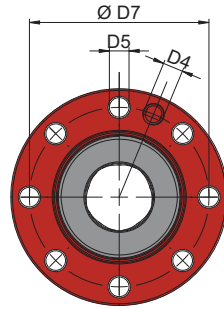
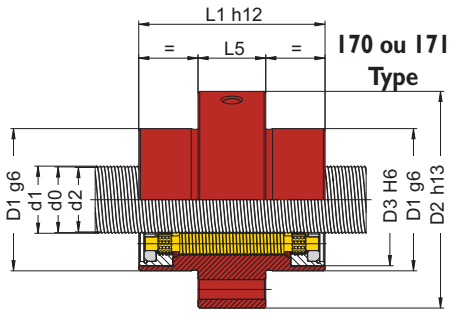

Types	D x P	SCREW					NUT												
		[mm]	[mm]	[mm]	[mm]	[mm]	[mm]	[mm]	[mm]	[mm]	Without wiper	With wipers	[mm]	[mm]	[mm]	[mm]	[mm]		
		Ø d1	Ø d0	Ø d2	Ø D1	Ø D2	Ø D3	D4	Ø D5	Ø D7	L1	L2	L3	L4	L5	L6			
RV	18 x	2	18,15	18	17,82	40	62	35	5	M6	5,8	51	48	58	41,7	18	4	18	42
		3	18,23		17,73														
		4	18,30		17,64														
		5	18,38		17,56														
		6	18,45		17,47														
		8	18,60		17,29														
		10	18,75		17,11														
RV	20 x	2	19,65	19,5	19,32	42	64	39	5	M6	5,8	53	55	65	43,7	20	4	20	44
		3	19,73		19,23														
		4	19,80		19,14														
		5	19,88		19,06														
		6	19,95		18,97														
		8	20,10		18,79														
		10	20,25		18,61														
RV	21 x	2	21,15	21	20,82	45	67	41	5	M6	5,8	56	55	65	47	20	5	18	47
		3	21,23		20,73														
		4	21,30		20,64														
		5	21,38		20,56														
		6	21,45		20,47														
		8	21,60		20,29														
		10	21,75		20,11														
RV	23 x	2	22,65	22,5	22,32	45	68	42	5	M6	7,0	56	55	65	46,7	20	4	20	47
		3	22,73		22,23														
		4	22,80		22,14														
		5	22,88		22,06														
		6	22,95		21,97														
		8	23,10		21,79														
		10	23,25		21,61														

Terms used in tables
D Reference diameter **d0** Nominal diameter
P Lead (travel per revolution) **d1** External diameter **d2** Thread root diameter

RV Range - Satellite roller screws

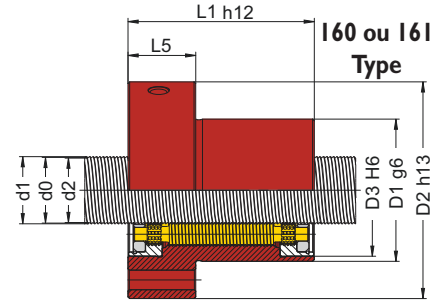
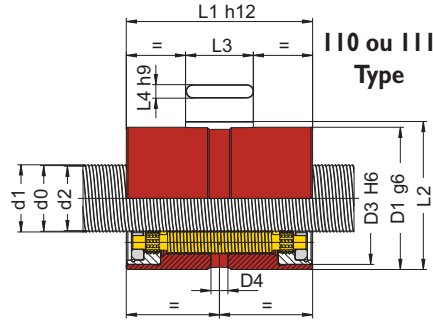

Types		TECHNICAL CHARACTERISTICS																		
		D x P	N	Helix angle [°]	SINGLE NUT				DOUBLE NUT					SPLIT NUT					DIRECT efficiency	INDIRECT efficiency
					Ca [kN]	C0a [kN]	Fk [N2/3µm]	Max axial backlash *	Ca [kN]	C0a [kN]	Fk [N2/3µm]	Fv [N]	Mv [Nm]	Ca [kN]	C0a [kN]	Fk [N2/3µm]	Fv [N]	Mv [Nm]		
RV	25 x	3	6	2,28	44,4	89,9	76,0	0,02	44,4	89,9	114,0	1366	0,35	24,5	44,9	47,9	1366	0,35	0,83	0,79
		6	4,55	49,0	81,8	49,9	0,03	49,0	81,8	74,8	1055	0,35	27,0	40,9	31,4	1055	0,35	0,88	0,87	
		12	9,04	57,4	83,1	35,3	0,05	57,4	83,1	53,0	538	0,35	31,6	41,6	22,2	538	0,35	0,88	0,87	
	5	2	1,52	65,1	160,6	107,1	0,02	65,1	160,6	160,7	1465	0,35	35,9	80,3	67,5	1465	0,35	0,78	0,71	
		4	3,04	77,0	161,2	74,1	0,02	77,0	161,2	111,2	1265	0,35	42,4	80,6	46,7	1265	0,35	0,86	0,83	
		5	3,79	81,3	161,5	66,0	0,03	81,3	161,5	99,0	1160	0,35	44,8	80,8	41,6	1160	0,35	0,87	0,85	
		6	4,55	84,2	159,6	59,6	0,03	84,2	159,6	89,4	1055	0,35	46,4	79,8	37,5	1055	0,35	0,88	0,87	
		8	6,06	90,8	162,4	51,9	0,04	90,8	162,4	77,8	860	0,35	50,0	81,2	32,7	860	0,35	0,89	0,88	
		10	7,55	89,6	148,1	43,6	0,05	89,6	148,1	65,4	686	0,35	49,4	74,1	27,5	686	0,35	0,89	0,88	
RV	27 x	2	5	1,35	71,3	175,1	110,2	0,02	71,3	175,1	165,3	1508	0,40	39,3	87,5	69,4	1508	0,40	0,76	0,68
		4	2,70	83,6	173,4	75,6	0,02	83,6	173,4	113,4	1332	0,40	46,1	86,7	47,6	1332	0,40	0,85	0,82	
		5	3,37	88,3	173,7	67,5	0,03	88,3	173,7	101,2	1238	0,40	48,6	86,8	42,5	1238	0,40	0,86	0,84	
		6	4,05	91,4	171,6	60,9	0,03	91,4	171,6	91,3	1143	0,40	50,4	85,8	38,3	1143	0,40	0,88	0,86	
		8	5,39	98,7	174,7	52,8	0,03	98,7	174,7	79,2	960	0,40	54,4	87,3	33,3	960	0,40	0,89	0,87	
		10	6,72	103,9	175,3	47,4	0,04	103,9	175,3	71,1	793	0,40	57,2	87,7	29,8	793	0,40	0,89	0,88	
		15	10,03	104,2	155,4	35,7	0,05	104,2	155,4	53,5	461	0,40	57,4	77,7	22,5	461	0,40	0,88	0,86	
RV	30 x	2	5	1,22	85,7	223,6	123,1	0,02	85,7	223,6	184,6	1715	0,50	47,2	111,8	77,5	1715	0,50	0,74	0,65
		4	2,43	100,8	221,6	84,0	0,02	100,8	221,6	126,1	1540	0,50	55,5	110,8	52,9	1540	0,50	0,84	0,80	
		5	3,04	107,2	224,7	75,5	0,03	107,2	224,7	113,3	1446	0,50	59,0	112,3	47,6	1446	0,50	0,86	0,83	
		6	3,64	111,1	222,4	68,3	0,03	111,1	222,4	102,4	1350	0,50	61,2	111,2	43,0	1350	0,50	0,87	0,85	
		8	4,85	117,2	217,7	58,1	0,03	117,2	217,7	87,1	1160	0,50	64,6	108,9	36,6	1160	0,50	0,88	0,87	
		10	6,06	126,3	226,5	52,9	0,04	126,3	226,5	79,3	983	0,50	69,6	113,3	33,3	983	0,50	0,89	0,88	
		15	9,04	127,3	201,5	39,9	0,05	127,3	201,5	59,8	615	0,50	70,1	100,7	25,1	615	0,50	0,88	0,87	
		20	11,98	156,8	229,8	35,2	0,05	156,8	229,8	52,9	363	0,50	86,4	114,9	22,2	363	0,50	0,86	0,83	
		25	14,86	166,2	238,7	32,1	0,05	166,2	238,7	48,1	206	0,50	91,6	119,3	20,2	206	0,50	0,81	0,77	
30	17,66	160,7	219,4	28,0	0,05	160,7	219,4	42,0	113	0,50	88,5	109,7	17,7	113	0,50	0,74	0,64			

* Axial backlash can be reduced on demand.

Terms used in tables	N Number of starts	F_k Rigidity factor
P Lead (travel per revolution)	Ca Dynamic load capacity	F_v Preloading force
D Reference diameter	C0a Static load capacity	M_v Preload torque

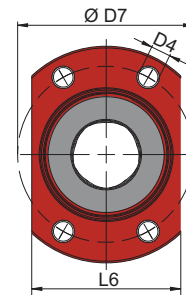
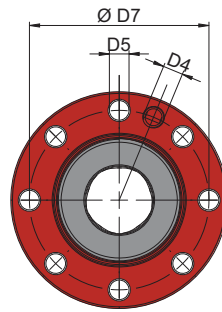
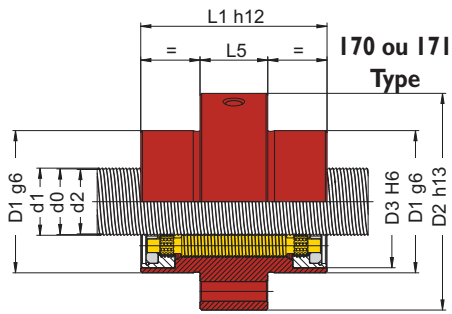

Types	D x P	SCREW			NUT														
		[mm]	[mm]	[mm]	[mm]	[mm]	[mm]	[mm]	[mm]	[mm]	Without wiper	With wipers	[mm]	[mm]	[mm]	[mm]	[mm]		
		Ø d1	Ø d0	Ø d2	Ø D1	Ø D2	Ø D3	D4	Ø D5	Ø D7	L1	L2	L3	L4	L5	L6			
RV	25 x	3	24,19		23,78	48	71	44	5	M6	7,0	59	48	58	49,7	18	4	20	50
		6	24,38	24	23,56														
		12	24,75		23,11														
	25 x	2	24,15		23,82	53	84	48	5	M6	7,0	70	64	78	55,5	25	6	20	55
		4	24,30		23,64														
		5	24,38		23,56														
		6	24,45	24	23,47														
		8	24,60		23,29														
		10	24,75		23,11														
		15	25,13		22,67														
RV	27 x	2	27,15		26,82	53	83	50	5	M6	7,0	68	65	79	55,2	20	5	22	55
		4	27,30		26,64														
		5	27,38		26,56														
		6	27,45	27	26,47														
		8	27,60		26,29														
		10	27,75		26,11														
		15	28,13		25,67														
RV	30 x	2	30,15		29,82	62	92	58	5	M6	9,0	77	71	85	64,7	20	6	27	64
		4	30,30		29,64														
		5	30,38		29,56														
		6	30,45		29,47														
		8	30,60	30	29,29														
		10	30,75		29,11														
		15	31,13		28,67														
		20	31,50		28,22														
		25	31,88		27,78														
		30	32,25		27,33														

Terms used in tables
D Reference diameter **d0** Nominal diameter
P Lead (travel per revolution) **d1** External diameter **d2** Thread root diameter

RV Range - Satellite roller screws

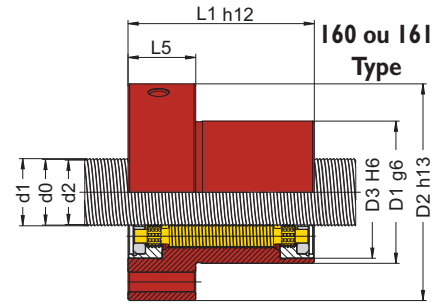
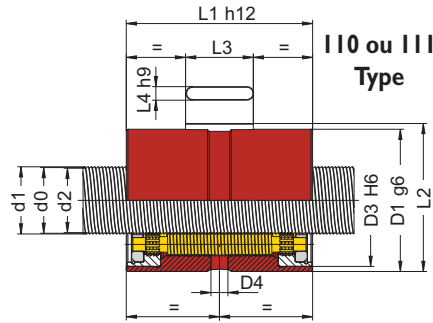

Types		TECHNICAL CHARACTERISTICS																			
		D x P	N	Helix angle [°]	SINGLE NUT				DOUBLE NUT					SPLIT NUT					DIRECT efficiency	INDIRECT efficiency	
					Ca [kN]	C0a [kN]	Fk [N/3µm]	Max axial backlash *	Ca [kN]	C0a [kN]	Fk [N/3µm]	Fv [N]	Mv [Nm]	Ca [kN]	C0a [kN]	Fk [N/3µm]	Fv [N]	Mv [Nm]			
RV	36 x	6	6	3,04	101,6	212,6	76,7	0,03	101,6	212,6	115,1	1 565	0,65	56,0	106,3	48,3	1 565	0,65	0,86	0,83	
		12	6	6,06	114,0	199,4	51,2	0,04	114,0	199,4	76,8	1 065	0,65	62,8	99,7	32,3	1 065	0,65	0,89	0,88	
		18	6	9,04	119,1	187,0	40,4	0,05	119,1	187,0	60,6	666	0,65	65,6	93,5	25,5	666	0,65	0,88	0,87	
		24	6	11,98	149,6	220,4	36,2	0,05	149,6	220,4	54,3	394	0,65	82,4	110,2	22,8	394	0,65	0,86	0,83	
		2	5	1,01	108,2	296,0	138,7	0,02	108,2	296,0	208,0	1 886	0,65	59,6	148,0	87,4	1 886	0,65	0,71	0,58	
		4	5	2,03	128,1	296,9	95,4	0,02	128,1	296,9	143,1	1 734	0,65	70,6	148,4	60,1	1 734	0,65	0,82	0,77	
	RV	39 x	5	5	2,53	135,2	297,4	84,5	0,03	135,2	297,4	126,7	1 651	0,65	74,5	148,7	53,2	1 651	0,65	0,84	0,81
			6	5	3,04	140,4	294,6	76,7	0,03	140,4	294,6	115,1	1 566	0,65	77,3	147,3	48,3	1 566	0,65	0,86	0,83
			8	5	4,05	149,4	292,3	65,6	0,04	149,4	292,3	98,5	1 393	0,65	82,3	146,2	41,3	1 393	0,65	0,88	0,86
			10	5	5,05	159,6	299,6	59,1	0,04	159,6	299,6	88,7	1 225	0,65	88,0	149,8	37,2	1 225	0,65	0,89	0,87
			15	5	7,55	172,3	293,8	47,7	0,05	172,3	293,8	71,6	850	0,65	94,9	146,9	30,1	850	0,65	0,89	0,88
			20	5	10,03	207,3	322,4	40,3	0,05	207,3	322,4	60,5	562	0,65	114,2	161,2	25,4	562	0,65	0,88	0,86
			2	5	0,94	127,1	368,8	152,8	0,02	127,1	368,8	229,2	2 153	0,80	70,0	184,4	96,3	2 153	0,80	0,69	0,55
4			5	1,87	149,7	366,2	104,9	0,02	149,7	366,2	157,4	2 000	0,80	82,5	183,1	66,1	2 000	0,80	0,81	0,76	
RV	44 x	6	6	2,49	145,5	341,5	94,2	0,03	145,5	341,5	141,3	2 089	1,00	80,2	170,8	59,3	2 089	1,00	0,84	0,81	
		12	6	4,96	168,8	334,6	65,0	0,03	168,8	334,6	97,5	1 560	1,00	93,0	167,3	40,9	1 560	1,00	0,89	0,87	
		18	6	7,42	176,3	313,1	50,5	0,05	176,3	313,1	75,7	1 092	1,00	97,1	156,6	31,8	1 092	1,00	0,89	0,88	
		24	6	9,85	222,4	368,1	45,1	0,05	222,4	368,1	67,7	730	1,00	122,5	184,0	28,4	730	1,00	0,88	0,86	
		30	6	12,24	219,8	339,8	38,9	0,05	219,8	339,8	58,3	472	1,00	121,1	169,9	24,5	472	1,00	0,85	0,83	

* Axial backlash can be reduced on demand.

Terms used in tables	N Number of starts	F_k Rigidity factor
P Lead (travel per revolution)	Ca Dynamic load capacity	F_v Preloading force
D Reference diameter	C0a Static load capacity	M_v Preload torque

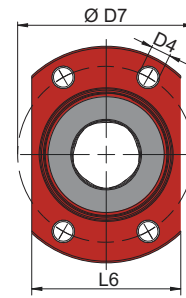
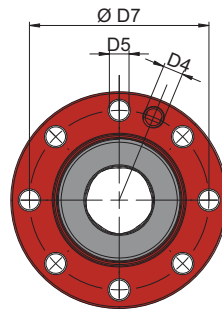
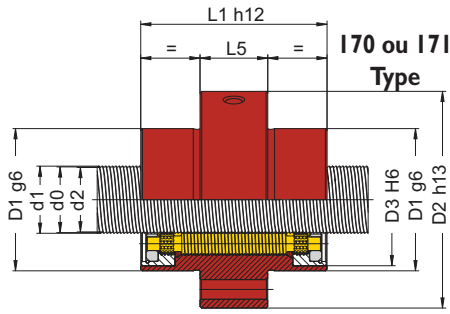

Types	D x P	SCREW							NUT																								
		[mm]	[mm]	[mm]	[mm]	[mm]	[mm]	[mm]	[mm]	[mm]	Without wiper	With wipers	[mm]	[mm]	[mm]	[mm]	[mm]																
		Ø d1	Ø d0	Ø d2	Ø D1	Ø D2	Ø D3	D4	Ø D5	Ø D7	L1	L2	L3	L4	L5	L6																	
RV 36 x	6	30,38	36	35,56	68	102	62	5	M6	9,0	85	68	80	70,2	25	5	27	70															
	12	30,75		35,11																													
	18	31,13		34,67																													
	24	31,50		34,22																													
	2	36,15	36	35,82	74	110	68	5	M6	9,0	92	82	96	76,7	28	6	25	76															
	4	36,30		35,64																													
	5	36,38		35,56																													
	6	36,45		35,47																													
	8	36,60		35,29																													
	10	36,75		35,11																													
	15	37,13		34,67																													
20	37,50	34,22																															
RV 39 x	2	39,15		39															38,82	80	116	72	5	M6	11,0	98	90	100	82,7	28	6	25	82
	4	39,30																	38,64														
	5	39,38	38,56																														
	6	39,45	38,47																														
	8	39,6	38,29																														
	10	39,75	38,11																														
	15	40,13	37,67																														
	25	40,88	36,78																														
RV 44 x	6	44,38	44	43,56	80	118	73	5	M6	11,0	100	80	90	82,7	28	6	25	84															
	12	44,75		43,11																													
	18	45,13		42,67																													
	24	45,50		42,22																													
	30	45,88		41,78																													

Terms used in tables
D Reference diameter **d0** Nominal diameter
P Lead (travel per revolution) **d1** External diameter **d2** Thread root diameter

RV Range - Satellite roller screws

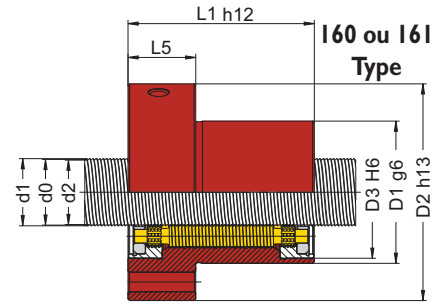
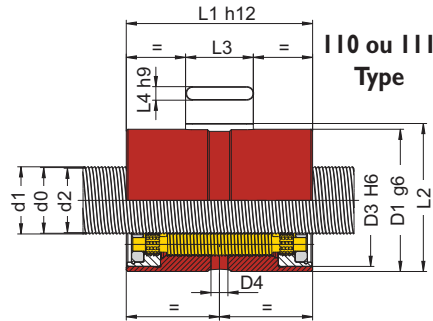

Types		TECHNICAL CHARACTERISTICS																DIRECT efficiency	INDIRECT efficiency	
		D x P	N	Helix angle [°]	SINGLE NUT				DOUBLE NUT					SPLIT NUT						
					Ca [kN]	C0a [kN]	Fk [N2/3µm]	Max axial backlash *	Ca [kN]	C0a [kN]	Fk [N2/3µm]	Fv [N]	Mv [Nm]	Ca [kN]	C0a [kN]	Fk [N2/3µm]	Fv [N]			Mv [Nm]
RV	48 x	5	6	1,90	169,7	448,8	117,3	0,03	169,7	448,8	176,0	2 430	1,20	93,5	224,4	73,9	2 430	1,20	0,81	0,76
		6	2,28	178,7	454,7	107,1	0,03	178,7	454,7	160,7	2 345	1,20	98,5	227,3	67,5	2 345	1,20	0,83	0,79	
		8	3,04	189,7	448,5	91,7	0,03	189,7	448,5	137,5	2 168	1,20	104,5	224,2	57,8	2 168	1,20	0,86	0,83	
		10	3,79	198,2	442,3	81,0	0,04	198,2	442,3	121,5	1 989	1,20	109,2	221,1	51,0	1 989	1,20	0,87	0,85	
		12	4,55	211,2	457,6	74,9	0,04	211,2	457,6	112,4	1 811	1,20	116,3	228,8	47,2	1 811	1,20	0,88	0,87	
		15	5,68	220,8	453,6	66,5	0,04	220,8	453,6	99,8	1 555	1,20	121,7	226,8	41,9	1 555	1,20	0,89	0,88	
		18	6,81	217,5	417,5	57,5	0,05	217,5	417,5	86,2	1 320	1,20	119,8	208,8	36,2	1 320	1,20	0,89	0,88	
		20	7,55	221,6	415,1	54,3	0,05	221,6	415,1	81,4	1 176	1,20	122,1	207,6	34,2	1 176	1,20	0,89	0,88	
		24	9,04	270,6	478,6	50,6	0,05	270,6	478,6	76,0	923	1,20	149,1	239,3	31,9	923	1,20	0,88	0,87	
	5	1,90	218,6	556,2	111,6	0,03	218,6	556,2	167,4	2 430	1,20	120,4	278,1	70,3	2 430	1,20	0,81	0,76		
	10	3,79	258,5	559,1	77,5	0,03	258,5	559,1	116,2	1 989	1,20	142,4	279,6	48,8	1 989	1,20	0,87	0,85		
	15	5,68	284,5	562,1	62,9	0,03	284,5	562,1	94,3	1 555	1,20	156,7	281,0	39,6	1 555	1,20	0,89	0,88		
	20	7,55	360,1	659,2	55,9	0,05	360,1	659,2	83,8	1 176	1,20	198,4	329,6	35,2	1 176	1,20	0,89	0,88		
	25	9,41	354,1	637,6	49,2	0,05	354,1	637,6	73,7	867	1,20	195,1	318,8	31,0	867	1,20	0,88	0,87		
	30	11,25	340,6	605,2	43,1	0,05	340,6	605,2	64,7	625	1,20	187,6	302,6	27,2	625	1,20	0,87	0,85		
RV	51 x	5	5	1,79	263,0	725,9	126,3	0,03	263,0	725,9	189,4	2 695	1,40	144,9	362,9	79,6	2 695	1,40	0,80	0,75
		10	3,57	308,0	717,3	86,9	0,03	308,0	717,3	130,3	2 241	1,40	169,7	358,7	54,7	2 241	1,40	0,87	0,85	
		15	5,35	339,0	720,4	70,3	0,04	339,0	720,4	105,5	1 788	1,40	186,8	360,2	44,3	1 788	1,40	0,89	0,87	
		20	7,12	425,8	844,0	62,6	0,05	425,8	844,0	93,9	1 383	1,40	234,6	422,0	39,4	1 383	1,40	0,89	0,88	
		25	8,87	432,0	861,1	56,5	0,05	432,0	861,1	84,8	1 044	1,40	238,0	430,5	35,6	1 044	1,40	0,89	0,87	
RV	56 x	6	6	1,95	219,5	584,9	119,0	0,03	219,5	584,9	178,5	2 763	1,60	120,9	292,5	75,0	2 763	1,60	0,81	0,77
		12	3,90	256,1	575,9	82,2	0,03	256,1	575,9	123,4	2 243	1,60	141,1	288,0	51,8	2 243	1,60	0,87	0,86	
		18	5,84	277,9	566,9	66,2	0,04	277,9	566,9	99,4	1 737	1,60	153,1	283,5	41,7	1 737	1,60	0,89	0,88	
		24	7,77	339,4	631,2	56,7	0,05	339,4	631,2	85,1	1 300	1,60	187,0	315,6	35,7	1 300	1,60	0,89	0,88	
		30	9,68	355,7	648,1	51,4	0,05	355,7	648,1	77,1	946	1,60	195,9	324,0	32,4	946	1,60	0,88	0,86	
		36	11,56	332,0	584,9	44,7	0,05	332,0	584,9	67,0	674	1,60	182,9	292,5	28,2	674	1,60	0,86	0,84	

* Axial backlash can be reduced on demand.

Terms used in tables	N Number of starts	F_k Rigidity factor
P Lead (travel per revolution)	Ca Dynamic load capacity	F_v Preloading force
D Reference diameter	C0a Static load capacity	M_v Preload torque

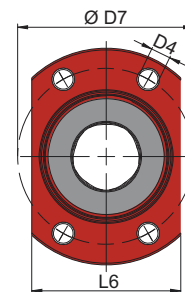
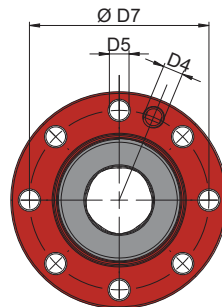
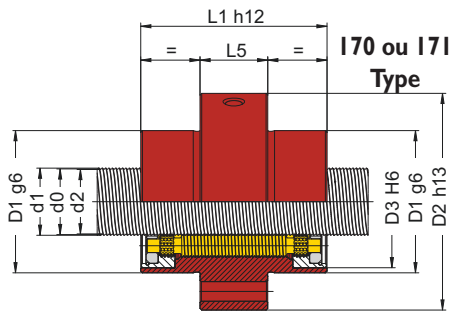

Types	D x P	SCREW			NUT																
		[mm]	[mm]	[mm]	[mm]	[mm]	[mm]	[mm]	[mm]	[mm]	[mm]	Without wiper	With wipers	[mm]	[mm]	[mm]	[mm]	[mm]			
		Ø d1	Ø d0	Ø d2	Ø D1	Ø D2	Ø D3	D4	Ø D5	Ø D7	L1	L2	L3	L4	L5	L6					
RV	48 x	5	48,31		47,63																
		6	48,38		47,56																
		8	48,50		47,41																
		10	48,63		47,26																
		12	48,75	48	47,11	86	122	80	7	M8 x 1	11,0	104	87	99	88,7	45	6	35	88		
		15	48,94		46,89																
		18	49,13		46,67																
	20	49,25		46,52																	
	24	49,50		46,22																	
	5	48,38		47,56																	
	10	48,75	48	47,11	100	150	94	7	M8 x 1	13,5	127	115	127	103	45	8	37	102			
	15	49,13		46,67																	
	20	49,50		46,22																	
	25	49,88		45,78																	
30	50,25		45,33																		
RV	51 x	5	51,38		50,56																
		10	51,75		50,11																
		15	52,13	51	49,67	102	147	94	7	M8 x 1	13,5	124	125	139	105	50	8	35	104		
		20	52,50		49,22																
		25	52,88		48,78																
RV	56 x	6	56,38		55,56																
		12	56,75		55,11																
		18	57,13	56	54,67	100	150	93	7	M8 x 1	13,5	127	100	112	103	40	8	37	102		
		24	57,50		54,22																
		30	57,88		53,78																
		36	58,25		53,33																

Terms used in tables
D Reference diameter **d0** Nominal diameter
P Lead (travel per revolution) **d1** External diameter **d2** Thread root diameter

RV Range - Satellite roller screws

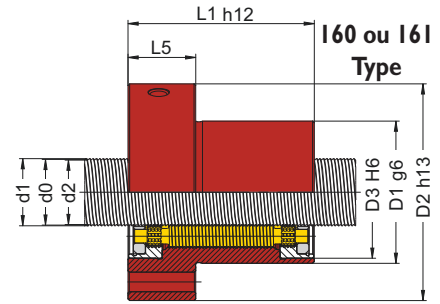
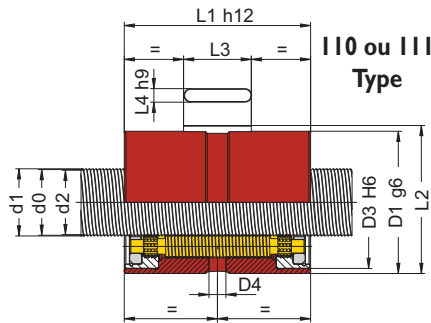

Types		TECHNICAL CHARACTERISTICS																			
		D x P	N	Helix angle [°]	SINGLE NUT				DOUBLE NUT					SPLIT NUT					DIRECT efficiency	INDIRECT efficiency	
					Ca [kN]	C0a [kN]	Fk [N2/3µm]	Max axial backlash *	Ca [kN]	C0a [kN]	Fk [N2/3µm]	Fv [N]	Mv [Nm]	Ca [kN]	C0a [kN]	Fk [N2/3µm]	Fv [N]	Mv [Nm]			
RV	60 x	6	6	1,82	248,5	689,4	128,2	0,04	248,5	689,4	192,4	2 936	1,80	136,9	344,7	80,8	2 936	1,80	0,80	0,75	
		10	6	3,04	277,8	678,4	97,2	0,04	277,8	678,4	145,9	2 601	1,80	153,1	339,2	61,3	2 601	1,80	0,86	0,83	
		12	6	3,64	290,3	679,7	88,3	0,04	290,3	679,7	132,5	2 429	1,80	159,9	339,8	55,6	2 429	1,80	0,87	0,85	
		18	6	5,45	315,6	669,9	71,2	0,04	315,6	669,9	106,7	1 926	1,80	173,9	335,0	44,8	1 926	1,80	0,89	0,87	
		20	6	6,06	327,4	684,4	68,2	0,04	327,4	684,4	102,3	1 769	1,80	180,4	342,2	43,0	1 769	1,80	0,89	0,88	
		30	6	9,04	393,2	747,8	54,6	0,07	393,2	747,8	81,8	1 108	1,80	216,6	373,9	34,4	1 108	1,80	0,88	0,87	
		42	6	12,56	393,0	755,2	46,4	0,07	393,0	755,2	69,6	586	1,80	216,5	377,6	29,3	586	1,80	0,85	0,82	
	60 x	5	5	1,52	340,4	1 005,9	147,9	0,04	340,4	1 005,9	221,8	3 014	1,80	187,5	502,9	93,1	3 014	1,80	0,78	0,71	
		10	5	3,04	380,1	925,8	96,5	0,04	380,1	925,8	144,8	2 601	1,80	209,4	462,9	60,8	2 601	1,80	0,86	0,83	
		15	5	4,55	415,0	915,9	77,5	0,04	415,0	915,9	116,3	2 173	1,80	228,6	458,0	48,9	2 173	1,80	0,88	0,87	
		20	5	6,06	500,4	1 057,1	68,4	0,04	500,4	1 057,1	102,6	1 769	1,80	275,7	528,5	43,1	1 769	1,80	0,89	0,88	
		25	5	7,55	494,0	1 029,9	60,2	0,05	494,0	1 029,9	90,3	1 412	1,80	272,2	515,0	37,9	1 412	1,80	0,89	0,88	
		30	5	9,04	495,5	1 034,1	55,1	0,07	495,5	1 034,1	82,6	1 108	1,80	273,0	517,1	34,7	1 108	1,80	0,88	0,87	
		35	5	10,52	470,0	958,1	48,4	0,07	470,0	958,1	72,5	857	1,80	258,9	479,0	30,5	857	1,80	0,87	0,85	
RV	64 x	6	6	1,71	255,5	802,2	137,3	0,04	255,5	802,2	206,0	3 089	2,00	142,7	401,1	86,5	3 089	2,00	0,79	0,74	
		12	6	3,42	303,1	791,8	94,5	0,04	303,1	791,8	141,8	2 598	2,00	169,3	395,9	59,5	2 598	2,00	0,87	0,84	
		18	6	5,12	332,8	781,4	76,0	0,04	332,8	781,4	114,0	2 101	2,00	185,9	390,7	47,9	2 101	2,00	0,89	0,87	
		24	6	6,81	428,8	932,6	68,2	0,04	428,8	932,6	102,3	1 650	2,00	239,6	466,3	42,9	1 650	2,00	0,89	0,88	
		30	6	8,49	408,9	854,6	57,7	0,06	408,9	854,6	86,6	1 266	2,00	228,4	427,3	36,4	1 266	2,00	0,89	0,87	
		36	6	10,15	397,3	812,6	51,4	0,07	397,3	812,6	77,2	953	2,00	221,9	406,3	32,4	953	2,00	0,88	0,86	
RV	70 x	6	6	1,59	321,2	1 120,0	160,5	0,04	-	-	-	-	-	-	-	-	-	-	0,78	0,72	
		12	6	3,17	381,9	1 108,2	110,5	0,04	-	-	-	-	-	-	-	-	-	-	-	0,86	0,84
		18	6	4,75	420,4	1 096,4	89,0	0,04	-	-	-	-	-	-	-	-	-	-	-	0,88	0,87
		24	6	6,32	525,1	1 265,4	78,4	0,04	-	-	-	-	-	-	-	-	-	-	-	0,89	0,88
		30	6	7,88	518,6	1 230,5	68,4	0,05	-	-	-	-	-	-	-	-	-	-	-	0,89	0,88
		36	6	9,43	498,8	1 149,4	60,3	0,07	-	-	-	-	-	-	-	-	-	-	-	0,88	0,87

* Axial backlash can be reduced on demand.

Terms used in tables	N Number of starts	F_k Rigidity factor
P Lead (travel per revolution)	Ca Dynamic load capacity	F_v Preloading force
D Reference diameter	C0a Static load capacity	M_v Preload torque



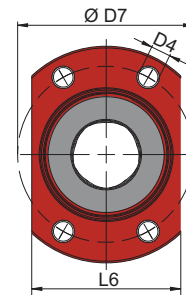
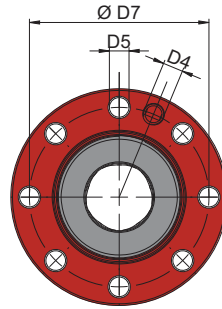
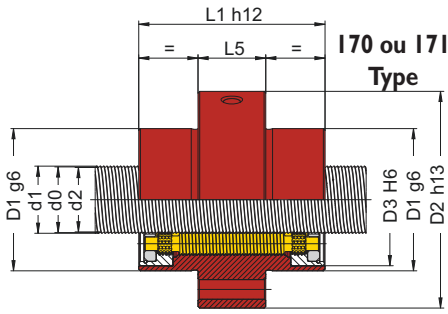

Types	D x P	SCREW			NUT														
		[mm]	[mm]	[mm]	[mm]	[mm]	[mm]	[mm]	[mm]	[mm]	[mm]	Without wiper [mm]	With wipers [mm]	[mm]	[mm]	[mm]	[mm]	[mm]	
		Ø d1	Ø d0	Ø d2	Ø D1	Ø D2	Ø D3	D4	Ø D5	Ø D7	L1	L2	L3	L4	L5	L6			
RV	60 x	6	60,38	60	59,56	110	150	100	10,5	M8 x 1	13,5	130	106	124	113,2	40	8	30	112
		10	60,63		59,26														
		12	60,75		59,11														
		18	61,13		58,67														
		20	61,25		58,52														
		30	61,88		57,78														
	42	62,63	56,89																
	5	60,38	60	59,56	122	180	110	10,5	M8 x 1	17,5	150	140	152	125,7	45	10	40	124	
	10	60,75		59,11															
	15	61,13		58,67															
	20	61,50		58,22															
	25	61,88		57,78															
	30	62,25		57,33															
	35	62,63		56,89															
RV	64 x	6		64,38															64
		12	64,75	63,11															
		18	65,13	62,67															
		24	65,50	62,22															
		30	65,88	61,78															
		36	66,25	61,33															
RV	70 x	6	69,38	69	68,56	130	172	115	9	M8 x 1	13,5	152	140	170	133,7	50	10	45	132
		12	69,75		68,11														
		18	70,13		67,67														
		24	70,50		67,22														
		30	70,88		66,78														
		36	71,25		66,33														

Terms used in tables
D Reference diameter **d0** Nominal diameter
P Lead (travel per revolution) **d1** External diameter **d2** Thread root diameter

RV Range - Satellite roller screws

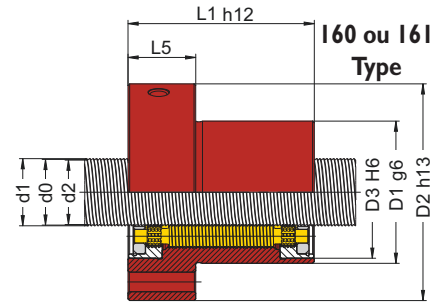
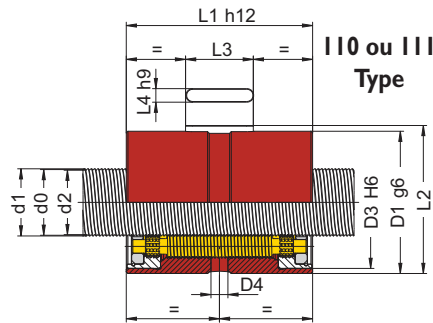
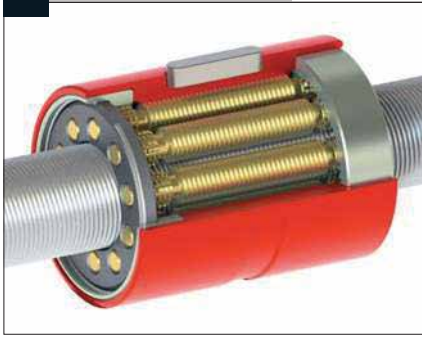

Types		TECHNICAL CHARACTERISTICS																		
		D x P	N	Helix angle [°]	SINGLE NUT				DOUBLE NUT					SPLIT NUT					DIRECT efficiency	INDIRECT efficiency
					Ca [kN]	C0a [kN]	Fk [N2/3µm]	Max axial backlash *	Ca [kN]	C0a [kN]	Fk [N2/3µm]	Fv [N]	Mv [Nm]	Ca [kN]	C0a [kN]	Fk [N2/3µm]	Fv [N]	Mv [Nm]		
RV	75 x	10	5	2,43	497,8	1 452,7	116,7	0,04	-	-	-	-	-	-	-	-	-	-	0,84	0,80
		15	5	3,64	549,5	1 440,4	94,3	0,04	-	-	-	-	-	-	-	-	-	-	0,87	0,85
		20	5	4,85	639,5	1 666,1	82,7	0,04	-	-	-	-	-	-	-	-	-	-	0,88	0,87
		25	5	6,06	642,4	1 651,7	73,7	0,04	-	-	-	-	-	-	-	-	-	-	0,89	0,88
		30	5	7,26	643,2	1 637,3	66,8	0,05	-	-	-	-	-	-	-	-	-	-	0,89	0,88
RV	80 x	12	6	2,73	385,3	1 040,9	105,3	0,04	-	-	-	-	-	-	-	-	-	-	0,85	0,82
		18	6	4,10	428,2	1 045,8	85,4	0,04	-	-	-	-	-	-	-	-	-	-	0,88	0,86
		24	6	5,45	524,6	1 225,8	75,7	0,04	-	-	-	-	-	-	-	-	-	-	0,89	0,87
		30	6	6,81	535,7	1 251,7	68,2	0,04	-	-	-	-	-	-	-	-	-	-	0,89	0,88
		36	6	8,15	508,8	1 148,6	59,0	0,06	-	-	-	-	-	-	-	-	-	-	0,89	0,87
RV	87 x	10	5	2,10	642,8	2 026,2	137,6	0,04	-	-	-	-	-	-	-	-	-	-	0,82	0,78
		15	5	3,14	656,7	1 862,8	105,1	0,04	-	-	-	-	-	-	-	-	-	-	0,86	0,84
		20	5	4,19	768,0	2 179,5	92,5	0,04	-	-	-	-	-	-	-	-	-	-	0,88	0,86
		25	5	5,23	767,8	2 140,3	81,9	0,04	-	-	-	-	-	-	-	-	-	-	0,89	0,87
		30	5	6,26	785,1	2 191,9	75,6	0,04	-	-	-	-	-	-	-	-	-	-	0,89	0,88
RV	92 x	12	6	2,38	532,8	1 646,7	129,1	0,04	-	-	-	-	-	-	-	-	-	-	0,83	0,80
		18	6	3,56	583,3	1 611,2	103,4	0,04	-	-	-	-	-	-	-	-	-	-	0,87	0,85
		24	6	4,75	695,3	1 886,2	91,5	0,04	-	-	-	-	-	-	-	-	-	-	0,88	0,87
		30	6	5,93	714,6	1 940,4	82,9	0,04	-	-	-	-	-	-	-	-	-	-	0,89	0,88
		36	6	7,10	709,8	1 898,9	74,8	0,05	-	-	-	-	-	-	-	-	-	-	0,89	0,88

* Axial backlash can be reduced on demand.

Terms used in tables	N Number of starts	F_k Rigidity factor
P Lead (travel per revolution)	Ca Dynamic load capacity	F_v Preloading force
D Reference diameter	C0a Static load capacity	M_v Preload torque

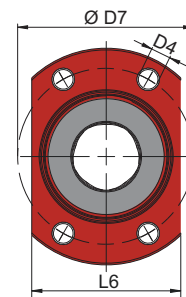
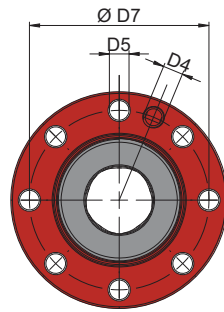
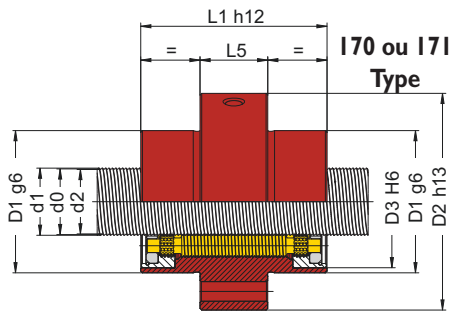

Types	SCREW				NUT														
		[mm]	[mm]	[mm]							Without wiper	With wipers							
	D x P	Ø d1	Ø d0	Ø d2	Ø D1	Ø D2	Ø D3	D4	Ø D5	Ø D7	L1	L2	L3	L4	L5	L6			
RV	75 x	10	75,75	75	74,11	150	210	140	10,5	M8 x l	17,5	180	175	191	153	63	10	45	152
		15	76,13		73,67														
		20	76,50		73,22														
		25	76,88		72,78														
		30	77,25		72,33														
RV	80 x	12	80,75	80	79,11	138	180	130	10,5	M8 x l	13,5	160	130	158	141,7	50	10	35	140
		18	81,13		78,67														
		24	81,50		78,22														
		30	81,88		77,78														
		36	82,25		77,33														
RV	87 x	10	87,75	87	86,11	175	235	162	10,5	M8 x l	17,5	200	190	215	178	63	10	45	177
		15	88,13		85,67														
		20	88,50		85,22														
		25	88,88		84,78														
		30	89,25		84,33														
RV	92 x	12	92,75	92	91,11	160	220	146	10,5	M8 x l	17,5	190	155	179	163	63	10	45	162
		18	93,13		90,67														
		24	93,50		90,22														
		30	93,88		89,78														
		36	94,25		89,33														

Terms used in tables
D Reference diameter **d0** Nominal diameter
P Lead (travel per revolution) **d1** External diameter **d2** Thread root diameter

RV Range - Satellite roller screws

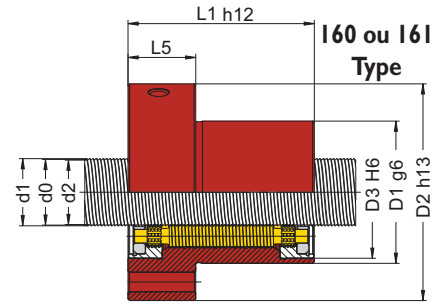
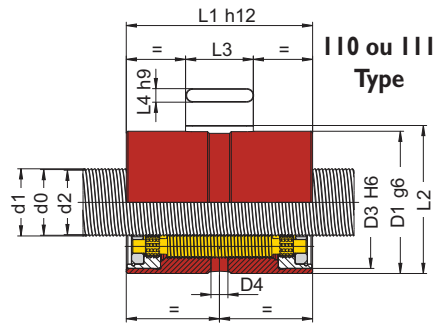

Types		TECHNICAL CHARACTERISTICS																			
		D x P	N	Helix angle [°]	SINGLE NUT				DOUBLE NUT					SPLIT NUT					DIRECT efficiency	INDIRECT efficiency	
					Ca [kN]	C0a [kN]	Fk [N2/3µm]	Max axial backlash *	Ca [kN]	C0a [kN]	Fk [N2/3µm]	Fv [N]	Mv [Nm]	Ca [kN]	C0a [kN]	Fk [N2/3µm]	Fv [N]	Mv [Nm]			
RV	100 x	12	6	2,19	790,2	2 649,7	153,2	0,05	-	-	-	-	-	-	-	-	-	-	-	0,82	0,79
		18	6	3,28	843,7	2 603,3	123,0	0,05	-	-	-	-	-	-	-	-	-	-	-	0,86	0,84
		24	6	4,37	858,2	2 610,2	106,0	0,05	-	-	-	-	-	-	-	-	-	-	-	0,88	0,86
		30	6	5,45	857,8	2 563,9	94,0	0,05	-	-	-	-	-	-	-	-	-	-	-	0,89	0,87
	15	5	2,76	1 044,9	3 598,6	135,4	0,05	-	-	-	-	-	-	-	-	-	-	-	-	0,85	0,82
	20	5	3,68	1 063,3	3 605,5	116,4	0,05	-	-	-	-	-	-	-	-	-	-	-	-	0,87	0,85
	25	5	4,60	1 077,2	3 612,3	103,8	0,05	-	-	-	-	-	-	-	-	-	-	-	-	0,88	0,87
	30	5	5,51	1 088,0	3 619,1	95,0	0,05	-	-	-	-	-	-	-	-	-	-	-	-	0,89	0,87
		35		6,42	1 106,7	3 679,6	88,6	0,05	-	-	-	-	-	-	-	-	-	-	-	0,89	0,88
RV	120 x	18	6	2,73	1 063,2	3 667,3	142,3	0,05	-	-	-	-	-	-	-	-	-	-	-	0,85	0,82
		24	6	3,64	1 082,0	3 675,6	122,6	0,05	-	-	-	-	-	-	-	-	-	-	-	0,87	0,85
		30	6	4,55	1 090,3	3 652,0	108,8	0,05	-	-	-	-	-	-	-	-	-	-	-	0,88	0,87
		36	6	5,45	1 107,2	3 692,0	99,9	0,05	-	-	-	-	-	-	-	-	-	-	-	0,89	0,87
	15	5	2,28	1 252,5	4 634,6	151,7	0,05	-	-	-	-	-	-	-	-	-	-	-	-	0,83	0,79
	20	5	3,04	1 214,1	4 320,3	124,4	0,05	-	-	-	-	-	-	-	-	-	-	-	-	0,86	0,83
	25	5	3,79	1 214,0	4 234,2	109,5	0,05	-	-	-	-	-	-	-	-	-	-	-	-	0,87	0,85
	30	5	4,55	1 232,5	4 274,3	100,0	0,05	-	-	-	-	-	-	-	-	-	-	-	-	0,88	0,87
		35		5,30	1 220,6	4 157,0	91,4	0,05	-	-	-	-	-	-	-	-	-	-	-	0,89	0,87

* Axial backlash can be reduced on demand.

Terms used in tables	N Number of starts	F_k Rigidity factor
P Lead (travel per revolution)	Ca Dynamic load capacity	F_v Preloading force
D Reference diameter	C0a Static load capacity	M_v Preload torque

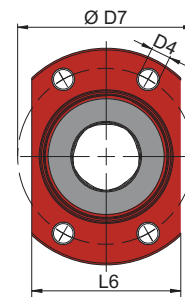
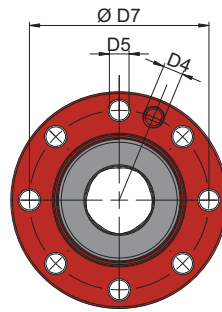
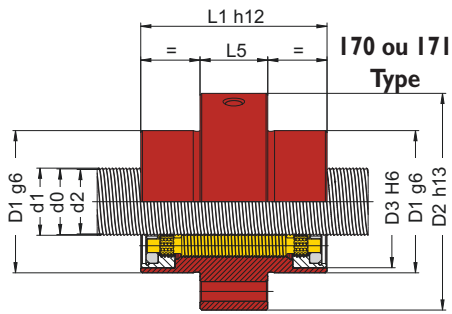

Types	D x P	SCREW			NUT														
		[mm]	[mm]	[mm]	[mm]	[mm]	[mm]	[mm]	[mm]	[mm]	[mm]	Without wiper	With wipers	[mm]	[mm]	[mm]	[mm]	[mm]	
		Ø d1	Ø d0	Ø d2	Ø D1	Ø D2	Ø D3	D4	Ø D5	Ø D7	L1	L2	L3	L4	L5	L6			
RV	100 x	12	100,75	100	99,11	185	260	172	10,5	M8 x l	17,5	225	200	220	188	63	10	50	187
		18	101,13		98,67														
		24	101,50		98,22														
		30	101,88		97,78														
	100 x	15	100,13	99	97,67	200	275	186	15	M8 x l	17,5	240	250	271	203	63	10	50	202
		20	100,50		97,22														
		25	100,88		96,78														
		30	101,25		96,33														
RV	120 x	18	121,13	120	118,67	220	260	200	15	M10 x l	17,5	240	230	260	223	100	10	50	222
		24	121,50		118,22														
		30	121,88		117,78														
		36	122,25		117,33														
	120 x	15	121,13	120	118,67	240	300	220	15	M10 x l	17,5	270	280	300	243	100	10	55	242
		20	121,50		118,22														
		25	121,88		117,78														
		30	122,25		117,33														
		35	122,63		116,89														

Terms used in tables
D Reference diameter **d0** Nominal diameter
P Lead (travel per revolution) **d1** External diameter **d2** Thread root diameter

HRV Range – Table of the standard available dimensions

Screw diameter (D)	Number of starts (N)	Lead (P)											
		15	18	20	24	25	30	35	36	40	42	50	
60	5	X		X		X	X						
75	5	X		X		X	X						
87	5	X		X		X	X						
100	5	X		X		X	X	X					
112	5	X		X		X	X	X					
120	5	X		X		X	X	X		X			
135	5	X		X		X	X	X		X		X	
150	5	X		X		X	X	X		X		X	
180	5			X			X			X		X	
210	5						X			X		X	



HRV 75 x 15

Dynamic capacities (Ca) diagram for roller screws as a function of the standard dimensions for standard HRV roller screws range

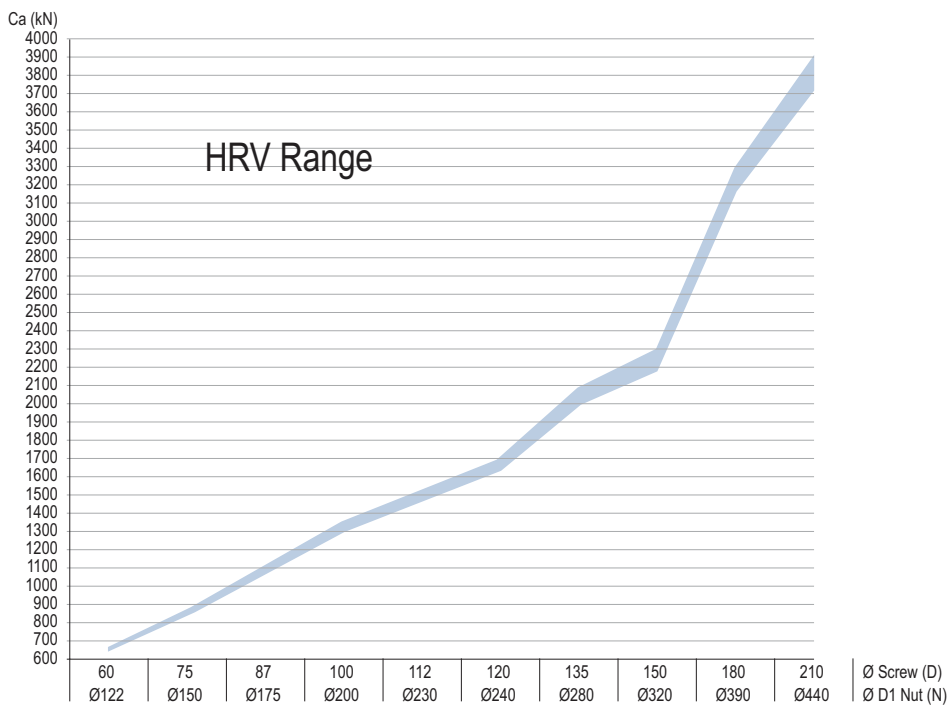

HRV Range - High Capacity satellite roller screws



HRV Range

Dimensions

pages

● HRV 60 / 75 / 87 / 100 / 112 / 120	42 et 43
● HRV 135 / 150 / 180 / 210	44 et 45

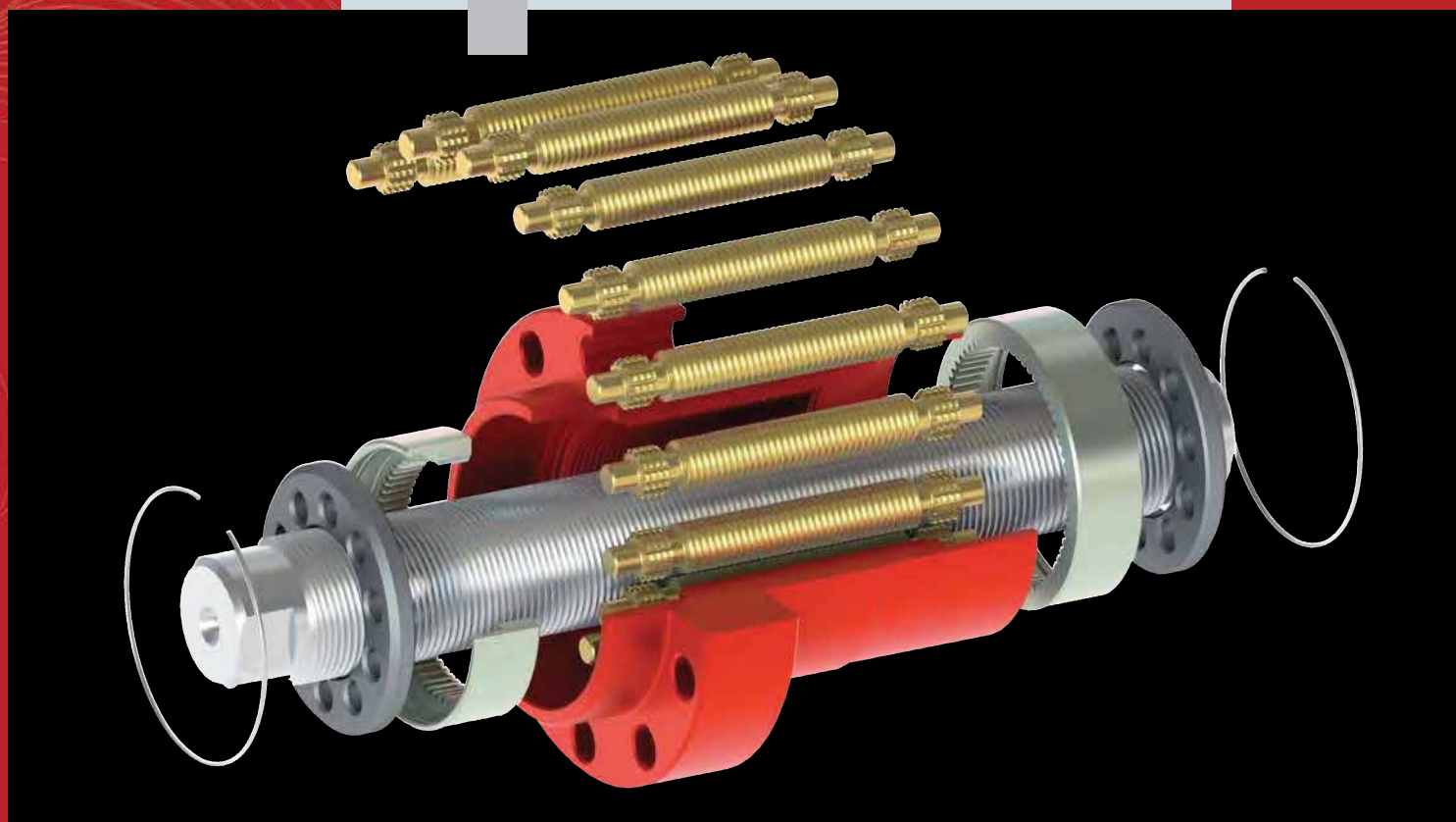

HRV Range - High Capacity satellite roller screws

HRV Range



Types			TECHNICAL CHARACTERISTICS						
			SINGLE NUT				Max axial backlash *	DIRECT efficiency	INDIRECT efficiency
D x P	N	Helix angle	Ca [kN]	C0a [kN]	Fk [Nz/3µm]				
HRV	60 x	15	4,55	654,9	1 512,4	88,9	0,04	0,88	0,87
		20	6,06	655,8	1 498,0	76,4	0,04	0,89	0,88
		25	7,55	665,2	1 522,3	68,9	0,04	0,89	0,88
		30	9,04	650,9	1 469,2	62,0	0,04	0,88	0,87
HRV	75 x	15	3,64	842,5	2 449,6	108,9	0,04	0,87	0,85
		20	4,85	862,0	2 480,3	95,0	0,04	0,88	0,87
		25	6,06	866,9	2 462,0	84,4	0,04	0,89	0,88
		30	7,26	858,0	2 395,2	76,0	0,04	0,89	0,88
HRV	87 x	15	3,14	1 074,0	3 531,7	127,9	0,04	0,86	0,84
		20	4,19	1 087,0	3 510,3	110,2	0,04	0,88	0,86
		25	5,23	1 106,3	3 545,9	99,1	0,04	0,89	0,87
		30	6,26	1 099,7	3 467,5	89,1	0,04	0,89	0,88
HRV	100 x	15	2,76	1 301,0	4 708,0	145,1	0,05	0,85	0,82
		20	3,68	1 323,9	4 716,1	124,9	0,05	0,87	0,85
		25	4,60	1 329,5	4 658,9	111,2	0,05	0,88	0,87
		30	5,51	1 354,7	4 732,1	102,2	0,05	0,89	0,87
		35	6,42	1 347,3	4 642,4	93,4	0,05	0,89	0,88
HRV	112x	15	2,43	1 526,9	5 937,5	162,5	0,05	0,84	0,80
		20	3,24	1 460,5	5 415,6	131,4	0,05	0,86	0,84
		25	4,05	1 480,1	5 425,0	117,3	0,05	0,88	0,86
		30	4,85	1 483,0	5 361,5	106,6	0,05	0,88	0,87
		35	5,66	1 482,6	5 298,0	98,0	0,05	0,89	0,88
HRV	120 x	15	2,28	1 694,4	6 949,4	174,1	0,05	0,83	0,79
		20	3,04	1 634,0	6 419,5	141,6	0,05	0,86	0,83
		25	3,79	1 656,2	6 429,5	126,3	0,05	0,87	0,85
		30	4,55	1 648,2	6 283,1	114,1	0,05	0,88	0,87
		35	5,30	1 668,7	6 332,0	106,0	0,05	0,89	0,87
		40	6,06	1 673,8	6 302,8	98,7	0,05	0,89	0,88

* Axial backlash can be reduced on demand.

Terms used in tables

P Lead (travel per revolution)
D Reference diameter

N Number of starts
Ca Dynamic load capacity
C0a Static load capacity

F_k Rigidity factor
F_v Preloading force
M_v Preload torque

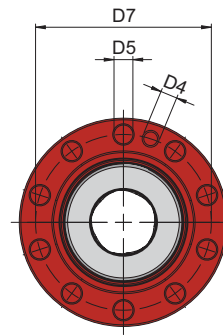
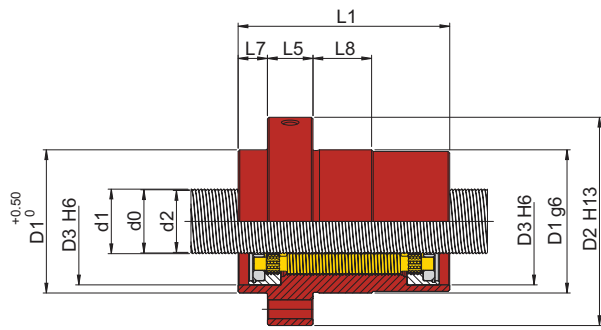

Types	SCREW							NUT						
		[mm]	[mm]	[mm]	[mm]	[mm]	[mm]	[mm]	[mm]	[mm]	[mm]	[mm]	[mm]	[mm]
	D x P	Ø d1	Ø d0	Ø d2	Ø D1	Ø D2	Ø D3	D4	Ø D5	Ø D7	L1	L5	L7	L8
HRV 60 x	15	61,13	60	58,67	122	180	110	M8 x l	17,5	150	171	30	20	40
	20	61,50		58,22										
	25	61,88		57,78										
	30	62,25		57,33										
HRV 75 x	15	76,13	75	73,67	150	210	140	M8 x l	17,5	180	213	35	25	40
	20	76,50		73,22										
	25	76,88		72,78										
	30	77,25		72,33										
HRV 87 x	15	88,13	87	85,67	175	235	162	M8 x l	17,5	200	245	40	25	40
	20	88,50		85,22										
	25	88,88		84,78										
	30	89,25		84,33										
HRV 100 x	15	100,13	99	97,67	200	245	186	M8 x l	17,5	224	280	50	25	40
	20	100,50		97,22										
	25	100,88		96,78										
	30	101,25		96,33										
	35	101,63		95,89										
HRV 112x	15	113,63	112,50	111,17	230	285	210	M10 x l	17,5	260	300	50	30	60
	20	114,00		110,72										
	25	114,38		110,28										
	30	114,75		109,83										
	35	115,13		109,39										
HRV 120 x	15	121,13	120	118,67	240	300	220	M10 x l	17,5	270	346	55	40	60
	20	121,50		118,22										
	25	121,88		117,78										
	30	122,25		117,33										
	35	122,63		116,89										
	40	123,00		116,44										

Terms used in tables
D Reference diameter **d0** Nominal diameter
P Lead (travel per revolution) **d1** External diameter **d2** Thread root diameter

HRV Range - High Capacity satellite roller screws

HRV Range

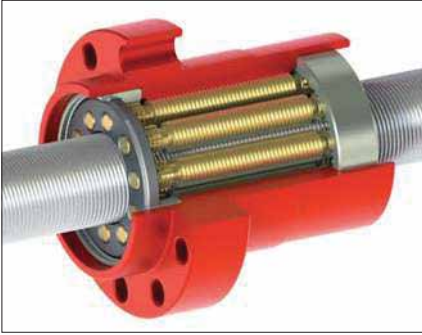

Types			TECHNICAL CHARACTERISTICS							
			SINGLE NUT				Max axial backlash *	DIRECT efficiency	INDIRECT efficiency	
D x P	N	Helix angle	Ca [kN]	C0a [kN]	Fk [Nz/3µm]					
HRV	135 x	5	15	2,03	2 061,7	9 351,8	198,3	0,07	0,82	0,77
			20	2,70	2 085,6	9 267,2	170,0	0,07	0,85	0,82
			25	3,37	1 988,6	8 461,7	142,4	0,07	0,86	0,84
			30	4,05	2 030,1	8 605,9	130,8	0,07	0,88	0,86
			35	4,72	2 054,8	8 661,2	121,7	0,07	0,88	0,87
			40	5,39	2 049,7	8 539,1	112,9	0,07	0,89	0,87
			50	6,72	2 031,9	8 295,8	99,3	0,07	0,89	0,88
HRV	150 x	5	15	1,82	2 235,9	10 488,5	206,4	0,07	0,80	0,75
			20	2,43	2 284,1	10 555,5	178,8	0,07	0,84	0,80
			25	3,04	2 294,1	10 410,0	157,7	0,07	0,86	0,83
			30	3,64	2 181,9	9 506,5	135,2	0,07	0,87	0,85
			35	4,25	2 215,7	9 616,2	125,9	0,07	0,88	0,86
			40	4,85	2 218,4	9 531,5	117,3	0,07	0,88	0,87
			50	6,06	2 216,3	9 362,4	103,7	0,07	0,89	0,88
HRV	180 x	5	20	2,03	3 204,3	17 663,4	225,0	0,10	0,82	0,77
			30	3,04	3 286,4	17 695,4	182,1	0,10	0,86	0,83
			40	4,05	3 155,2	16 249,9	148,4	0,10	0,88	0,86
			50	5,05	3 195,3	16 278,8	133,0	0,10	0,89	0,87
HRV	210 x	5	30	2,60	3 893,4	22 704,7	202,0	0,10	0,84	0,81
			40	3,47	3 723,7	20 709,1	163,5	0,10	0,87	0,85
			50	4,33	3 773,0	20 743,4	146,3	0,10	0,88	0,86

* Axial backlash can be reduced on demand.

Terms used in tables

P Lead (travel per revolution)
D Reference diameter

N Number of starts
Ca Dynamic load capacity
C0a Static load capacity

F_k Rigidity factor
F_v Preloading force
M_v Preload torque

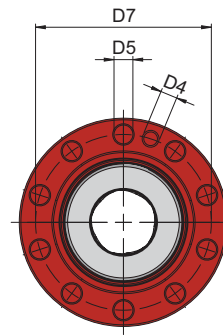
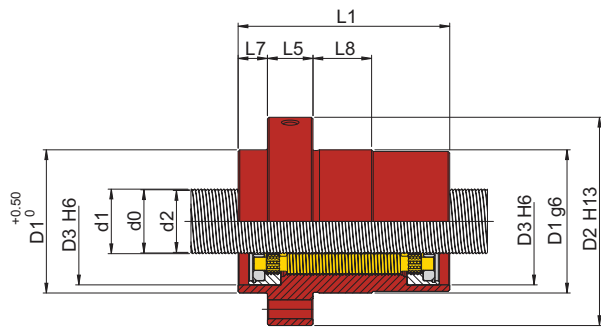

Types	D x P	SCREW			NUT										
		[mm]	[mm]	[mm]	[mm]	[mm]	[mm]	[mm]	[mm]	[mm]	[mm]	[mm]	[mm]	[mm]	[mm]
		Ø d1	Ø d0	Ø d2	Ø D1	Ø D2	Ø D3	D4	Ø D5	Ø D7	L1	L5	L7	L8	
HRV 135 x	15	136,13	135	133,67	280	345	260	M12	20,0	315	370	60	35	80	
	20	136,50		133,22											
	25	136,88		132,78											
	30	137,25		132,33											
	35	137,63		131,89											
	40	138,00		131,44											
	50	138,75		130,55											
HRV 150 x	15	151,13	150	148,67	320	385	280	M12	20,0	355	412	70	50	80	
	20	151,50		148,22											
	25	151,88		147,78											
	30	152,25		147,33											
	35	152,63		146,89											
	40	153,00		146,44											
	50	153,75		145,55											
HRV 180 x	20	181,50	180	178,22	390	470	330	M12	24,0	433	528	90	55	100	
	30	182,25		177,33											
	40	183,00		176,44											
	50	183,75		175,55											
HRV 210 x	30	212,25	210	207,33	440	530	398	M12	26,0	490	570	100	55	100	
	40	213,00		206,44											
	50	213,75		205,55											

Terms used in tables
D Reference diameter **d0** Nominal diameter
P Lead (travel per revolution) **d1** External diameter **d2** Thread root diameter

RVI Range – Table of the standard available dimensions

Screw diameter (D)	Number of starts (N)	Lead (P)															
		1	2	3	4	5	6	7	8	9	10	12	14	15	16		
10,5	3		x														
12	3	x	x														
13,5	3	x	x														
15	3	x	x	x													
18	3	x	x	x													
21	3		x	x	x												
24	3		x	x	x	x											
27	3		x	x	x	x											
28	4		x	x	x	x	x										
30	3		x	x	x	x	x										
36	4		x	x	x	x	x	x									
39	3			x	x	x	x	x	x								
44	4			x	x	x	x	x	x	x							
48	3			x	x	x	x	x	x	x	x						
51	3			x	x	x	x	x	x	x	x						
56	4				x	x	x	x	x	x	x	x					
60	4				x	x	x	x	x	x	x	x					
64	4				x	x	x	x	x	x	x	x	x				
70	5						x		x		x	x	x	x			
75	5						x		x		x	x	x	x			
80	4						x		x		x	x	x		x		

RVI Range



RVI 8 x 0.5



RVI 39 x 6

RVI Range - Inverted satellite roller screws



RVI Range

<i>Dimensions</i>	<i>pages</i>
● RVI 10,5 / 12 / 13,5 / 15 / 18 / 21 / 24 / 27 / 28	58
● RVI 30 / 36 / 39 / 44 / 48	49
● RVI 51 / 56 / 60	50
● RVI 64 / 70 / 75 / 80	51



RVI Range - Inverted satellite roller screws

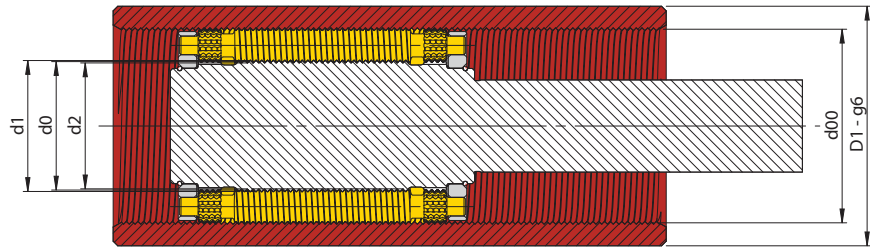
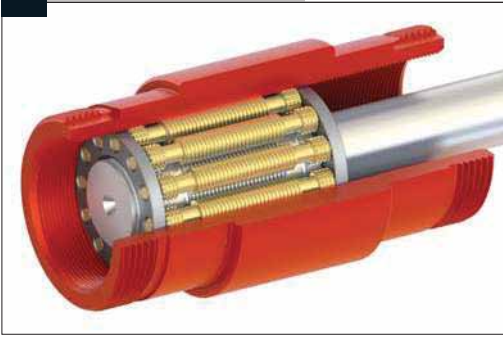

RVI Range

Types				TECHNICAL CHARACTERISTICS						SCREW			NUT	
	D x P	N	Helix angle	Ca [kN]	C0a [kN]	Fk [N2/3µm]	Max axial backlash *	DIRECT efficiency	INDIRECT efficiency	Ø d1 [mm]	Ø d0 [mm]	Ø d2 [mm]	Ø d00 [mm]	Ø DI [mm]
RVI	10,5 x 2,0	3	3,47	13,4	20,8	32,6	0,02	0,87	0,85	10,75	10,50	10,20	17,50	24
RVI	12 x	1,0	1,52	13,9	26,8	52,1	0,02	0,78	0,71	12,13	12,00	11,85	20	26
		2,0	3,04	16,5	27,1	36,5	0,02	0,86	0,83	12,25		11,70		
RVI	13,5 x	1,0	1,35	16,1	31,5	56,8	0,02	0,76	0,68	13,63	13,50	13,35	22,50	30
		2,0	2,70	17,9	28,9	37,2	0,02	0,85	0,82	13,75		13,20		
RVI	15 x	1,0	1,22	23,7	56,0	74,1	0,02	0,74	0,65	15,13	15,00	14,85	25	32
		2,0	2,43	26,0	50,2	47,9	0,02	0,84	0,80	15,25		14,70		
		3,0	3,64	29,1	51,5	39,4	0,03	0,87	0,85	15,38		14,56		
RVI	18 x	1,0	1,01	30,6	76,8	85,1	0,02	0,71	0,58	18,13	18,00	17,85	30	38
		2,0	2,03	36,2	77,2	59,0	0,02	0,82	0,77	18,25		17,70		
		3,0	3,04	39,1	74,9	46,9	0,03	0,86	0,83	18,38		17,56		
RVI	21 x	2,0	1,74	54,5	106,0	67,5	0,02	0,80	0,74	21,25	21,00	20,70	35	45
		3,0	2,60	59,6	104,8	54,2	0,03	0,84	0,81	21,38		20,56		
		4,0	3,47	63,3	103,7	46,5	0,03	0,87	0,85	21,50		20,41		
RVI	24 x	2,0	1,52	73,8	161,0	81,2	0,02	0,78	0,71	24,25	24,00	23,70	40	50
		3,0	2,28	81,4	161,5	66,0	0,03	0,83	0,79	24,38		23,56		
		4,0	3,04	87,3	162,0	56,8	0,03	0,86	0,83	24,50		23,41		
		5,0	3,79	92,1	162,5	50,9	0,03	0,87	0,85	24,63		23,26		
RVI	27 x	2,0	1,35	80,1	173,1	83,1	0,02	0,76	0,68	27,25	27,00	26,70	45	55
		3,0	2,03	88,4	173,7	67,5	0,03	0,82	0,77	27,38		26,56		
		4,0	2,70	94,8	174,3	58,0	0,03	0,85	0,82	27,50		26,41		
		5,0	3,37	100,0	174,8	51,8	0,03	0,86	0,84	27,63		26,26		
RVI	28 x	2,0	1,30	61,4	140,0	92,5	0,02	0,75	0,67	28,19	28,00	27,78	42	52
		3,0	1,95	67,8	140,5	75,0	0,02	0,81	0,77	28,28		27,67		
		4,0	2,60	71,7	137,8	63,9	0,03	0,84	0,81	28,38		27,56		
		5,0	3,25	72,5	129,8	54,5	0,03	0,86	0,84	28,47		27,44		
		6,0	3,90	76,3	131,6	50,0	0,03	0,87	0,86	28,56		27,33		

* Axial backlash can be reduced on demand.

Terms used in tables	Ca Dynamic load capacity	d0 Nominal diameter
P Lead (travel per revolution)	C0a Static load capacity	d2 Thread root diameter
D Reference diameter	Fk Rigidity factor	d00 Nominal diameter nut
N Number of starts	d1 External diameter	DI Mini external diameter

RVI Range - Inverted satellite roller screws

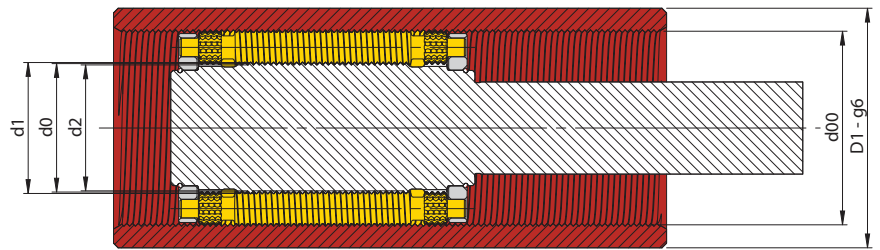
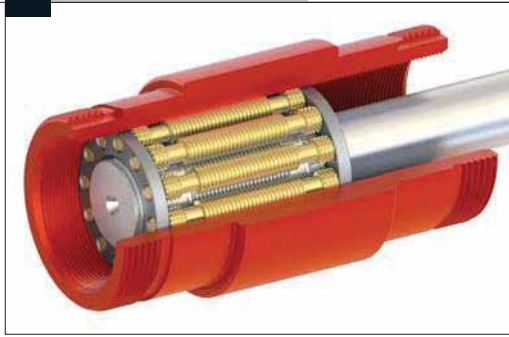

RVI Range

Types	D x P	N	[°] Helix angle	TECHNICAL CHARACTERISTICS						SCREW			NUT		
				[kN] Ca	[kN] C0a	[Nz/3µm] Fk	Max axial backlash *	DIRECT efficiency	INDIRECT efficiency	[mm] Ø d1	[mm] Ø d0	[mm] Ø d2	[mm] Ø d00	[mm] Ø D1	
RVI	30 x	2	3	1,22	97,2	224,1	93,4	0,02	0,74	0,65	30,25	30	29,70	50	60
		3		1,82	107,3	224,7	75,5	0,03	0,80	0,75	30,38		29,56		
		4		2,43	113,6	220,8	64,3	0,03	0,84	0,80	30,50		29,41		
		5		3,04	119,2	219,2	57,0	0,03	0,86	0,83	30,63		29,26		
		6		3,64	126,9	226,5	52,9	0,04	0,87	0,85	30,75		29,11		
RVI	36 x	2	4	1,01	86,9	215,4	111,7	0,02	0,71	0,58	36,19	36	35,78	54	64
		3		1,52	95,4	214,0	89,3	0,02	0,78	0,71	36,28		35,67		
		4		2,03	101,8	212,6	76,7	0,03	0,82	0,77	36,38		35,56		
		5		2,53	106,2	209,2	67,7	0,03	0,84	0,81	36,47		35,44		
		6		3,04	111,0	209,8	61,7	0,03	0,86	0,83	36,56		35,33		
		7		3,54	117,8	218,1	58,0	0,03	0,87	0,85	36,66		35,22		
RVI	39 x	3	3	1,40	159,5	372,0	93,2	0,03	0,76	0,69	39,38	39	38,56	65	75
		4		1,87	170,3	369,9	80,3	0,03	0,81	0,76	39,50		38,41		
		5		2,34	178,9	367,8	71,2	0,03	0,83	0,80	39,63		38,26		
		6		2,80	186,1	365,7	64,5	0,04	0,85	0,82	39,75		38,11		
		7		3,27	194,1	369,4	59,8	0,04	0,86	0,84	39,88		37,96		
		8		3,74	201,4	373,1	56,3	0,04	0,87	0,85	40,00		37,81		
RVI	44 x	3	4	1,24	135,1	338,4	109,3	0,02	0,74	0,65	44,28	44	43,67	66	76
		4		1,66	145,6	341,5	94,2	0,03	0,79	0,73	44,38		43,56		
		5		2,07	153,1	339,8	83,7	0,03	0,82	0,78	44,47		43,44		
		6		2,49	157,9	333,2	75,3	0,03	0,84	0,81	44,56		43,33		
		7		2,90	166,8	343,6	70,6	0,03	0,85	0,83	44,66		43,22		
		8		3,31	169,2	334,6	65,0	0,04	0,86	0,84	44,75		43,11		
		9		3,73	171,8	328,0	60,6	0,04	0,87	0,85	44,84		43,00		
		10		3,79	171,8	328,0	60,6	0,04	0,87	0,85	44,84		43,00		
RVI	48 x	3	3	1,14	218,7	556,2	111,6	0,03	0,73	0,63	48,38	48	47,56	80	90
		4		1,52	234,6	557,2	95,4	0,03	0,78	0,71	48,50		47,41		
		5		1,90	246,8	554,6	85,0	0,03	0,81	0,76	48,63		47,26		
		6		2,28	259,0	559,1	77,5	0,04	0,83	0,79	48,75		47,11		
		7		2,66	262,4	538,7	70,1	0,04	0,84	0,82	48,88		46,96		
		8		3,04	277,7	561,1	66,7	0,04	0,86	0,83	49,00		46,81		
		9		3,42	285,7	562,1	62,9	0,05	0,87	0,84	49,13		46,67		
		10		3,79	286,0	541,7	58,6	0,05	0,87	0,85	49,25		46,52		

* Axial backlash can be reduced on demand.

Terms used in tables	Ca Dynamic load capacity	d0 Nominal diameter
P Lead (travel per revolution)	C0a Static load capacity	d2 Thread root diameter
D Reference diameter	Fk Rigidity factor	d00 Nominal diameter nut
N Number of starts	d1 External diameter	D1 Mini external diameter

RVI Range - Inverted satellite roller screws

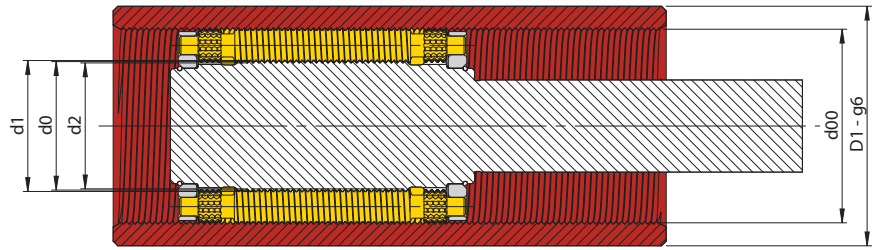
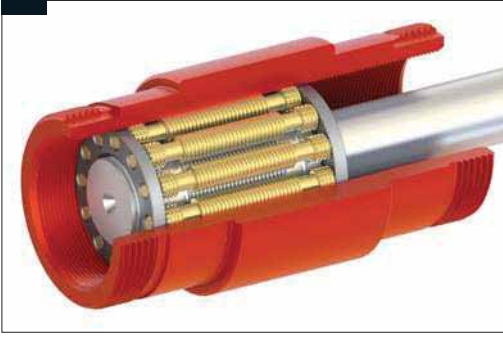

RVI Range

Types	TECHNICAL CHARACTERISTICS									SCREW			NUT		
	D x P	N	Helix angle [°]	[kN]	[kN]	[N2/3µm]	Max axial backlash *	DIRECT efficiency	INDIRECT efficiency	[mm]	[mm]	[mm]	[mm]	[mm]	
				Ca	C0a	Fk				Ø d1	Ø d0	Ø d2	Ø d00	Ø D1	
RVI	51 x	3	3	1,07	263,1	725,9	126,3	0,03	0,72	0,60	51,38	51	50,56	85	99
			4	1,43	279,5	715,2	106,6	0,03	0,77	0,70	51,50		50,41		
			5	1,79	298,1	727,9	96,2	0,03	0,80	0,75	51,63		50,26		
			6	2,14	308,5	717,3	86,9	0,04	0,82	0,78	51,75		50,11		
			7	2,50	320,2	718,3	80,0	0,04	0,84	0,81	51,88		49,96		
			8	2,86	326,2	703,9	74,0	0,04	0,85	0,83	52,00		49,81		
			9	3,22	340,3	720,4	70,3	0,05	0,86	0,84	52,13		49,67		
			10	3,57	346,6	713,7	66,5	0,05	0,87	0,85	52,25	49,52			
RVI	56 x	4	4	1,30	219,6	584,9	119,0	0,03	0,75	0,67	56,38	56	55,56	84	98
			5	1,63	231,9	585,8	105,9	0,03	0,79	0,73	56,47		55,44		
			6	1,95	240,8	580,4	96,0	0,03	0,81	0,77	56,56		55,33		
			7	2,28	250,8	584,4	88,8	0,03	0,83	0,79	56,66		55,22		
			8	2,60	256,5	575,9	82,2	0,04	0,84	0,81	56,75		55,11		
			9	2,93	260,4	564,4	76,6	0,04	0,85	0,83	56,84		55,00		
			10	3,25	274,4	590,0	74,1	0,04	0,86	0,84	56,94		54,89		
			12	3,90	279,0	566,9	66,2	0,05	0,87	0,86	57,13	54,67			
RVI	60 x	4	4	1,22	248,6	689,4	128,2	0,03	0,74	0,65	60,38	60	59,56	90	108
			5	1,52	259,3	676,9	112,7	0,03	0,78	0,71	60,47		59,44		
			6	1,82	272,7	684,5	103,1	0,03	0,80	0,75	60,56		59,33		
			7	2,13	281,4	678,7	94,8	0,03	0,82	0,78	60,66		59,22		
			8	2,43	290,7	679,7	88,3	0,04	0,84	0,80	60,75		59,11		
			9	2,73	298,2	677,2	83,0	0,04	0,85	0,82	60,84		59,00		
			10	3,04	306,9	681,5	78,9	0,04	0,86	0,83	60,94		58,89		
			12	3,64	316,7	669,9	71,2	0,05	0,87	0,85	61,13	58,67			

* Axial backlash can be reduced on demand.

Terms used in tables	Ca Dynamic load capacity	d0 Nominal diameter
P Lead (travel per revolution)	C0a Static load capacity	d2 Thread root diameter
D Reference diameter	Fk Rigidity factor	d00 Nominal diameter nut
N Number of starts	d1 External diameter	D1 Mini external diameter

RVI Range - Inverted satellite roller screws

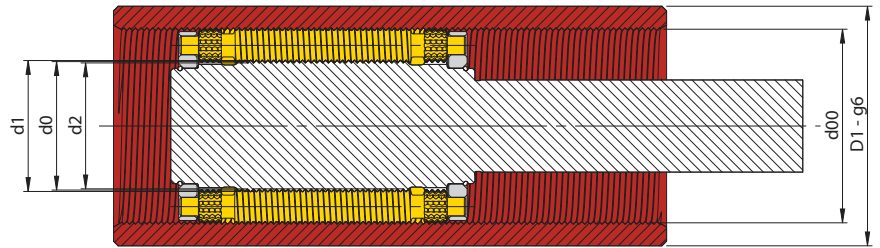
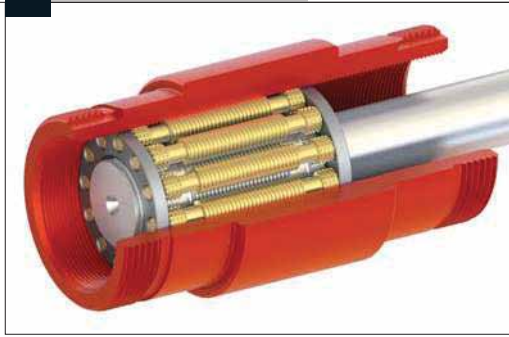

RVI Range

Types	D x P	N	β Helix angle	TECHNICAL CHARACTERISTICS						SCREW			NUT	
				Ca [kN]	C0a [kN]	Fk [Nz/3µm]	Max axial backlash *	DIRECT efficiency	INDIRECT efficiency	Ø d1 [mm]	Ø d0 [mm]	Ø d2 [mm]	Ø d00 [mm]	Ø D1 [mm]
RVI	64 x	4	1,14	278,7	802,2	137,3	0,03	0,73	0,63	64,38	64	63,56	96	114
			1,42	291,9	792,4	120,9	0,03	0,77	0,69	64,47		63,44		
			1,71	306,0	797,0	110,1	0,03	0,79	0,74	64,56		63,33		
			1,99	319,5	805,1	102,2	0,04	0,81	0,77	64,66		63,22		
			2,28	326,4	791,8	94,5	0,04	0,83	0,79	64,75		63,11		
			2,56	337,8	799,9	89,3	0,04	0,84	0,81	64,84		63,00		
			2,85	340,6	779,5	83,5	0,04	0,85	0,83	64,94		62,89		
			3,42	355,9	781,4	76,0	0,05	0,87	0,84	65,13		62,67		
			3,98	377,8	811,8	71,7	0,05	0,88	0,86	65,31		62,44		
RVI	70 x	5	1,56	260,3	722,7	123,1	0,02	0,78	0,72	70,45	70	69,47	98	120
			2,08	276,2	712,1	105,2	0,03	0,82	0,78	70,60		69,29		
			2,60	291,6	713,8	93,8	0,04	0,84	0,81	70,75		69,11		
			3,12	308,0	727,8	86,1	0,04	0,86	0,84	70,90		68,93		
			3,64	317,9	723,3	79,2	0,04	0,87	0,85	71,05		68,75		
			3,90	317,2	702,6	75,4	0,05	0,87	0,86	71,13		68,67		
RVI	75 x	5	1,46	294,7	851,9	132,4	0,03	0,77	0,70	75,45	75	74,47	105	127
			1,94	314,6	847,1	113,5	0,03	0,81	0,77	75,60		74,29		
			2,43	330,5	842,3	100,7	0,04	0,84	0,80	75,75		74,11		
			2,92	343,7	837,5	91,5	0,04	0,85	0,83	75,90		73,93		
			3,40	358,5	845,9	84,7	0,04	0,87	0,84	76,05		73,75		
			3,64	360,0	830,3	81,0	0,05	0,87	0,85	76,13		73,67		
RVI	80 x	4	1,37	387,4	1 038,4	121,9	0,03	0,76	0,68	80,56	80	79,33	120	142
			1,82	415,6	1 040,9	105,3	0,04	0,80	0,75	80,75		79,11		
			2,28	443,2	1 060,8	94,5	0,04	0,83	0,79	80,94		78,89		
			2,73	458,6	1 045,8	85,4	0,05	0,85	0,82	81,13		78,67		
			3,19	476,0	1 048,3	78,9	0,05	0,86	0,84	81,31		78,44		
			3,64	559,4	1 225,8	75,7	0,05	0,87	0,85	81,50		78,22		

* Axial backlash can be reduced on demand.

Terms used in tables

P Lead (travel per revolution)
D Reference diameter
N Number of starts

Ca Dynamic load capacity
C0a Static load capacity
Fk Rigidity factor
d1 External diameter

d0 Nominal diameter
d2 Thread root diameter
d00 Nominal diameter nut
D1 Mini external diameter

RVR Range – Table of the standard available dimensions

Screw diameter (D)	Lead (P)						
	0,25	0,5	1	2	3	4	5
8	X	X	X	X			
10	X	X	X	X			
12	X	X	X	X			
16		X	X	X			
20		X	X	X			
25			X	X			
32			X	X		X	
36			X	X			
40			X	X		X	
50			X	X	X	X	
63				X	X	X	
80				X	X	X	
100					X	X	X
125							X

RVR Range



RVR 12 x 1

RVR Range - Satellite roller screw - mechanism with recirculating rollers



Dimensions

	pages
RVR 8 / 10 / 12 / 16 / 20 / 25 / 32 / 36 / 40	54 et 55
RVR 50 / 63 / 80 / 100 / 125	56 et 57

RVR Range

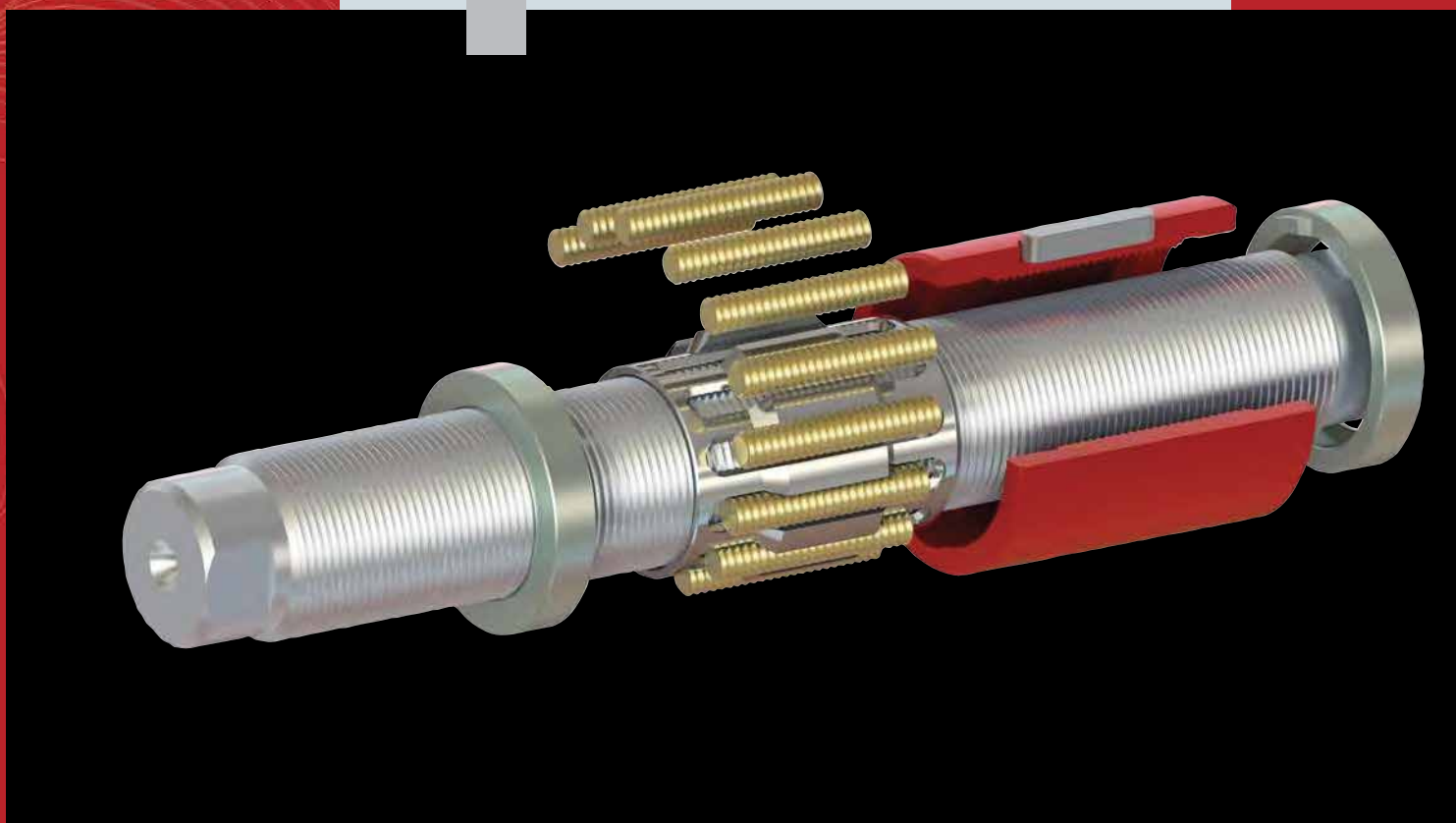

RVR Range - Satellite roller screw - mechanism with recirculating rollers

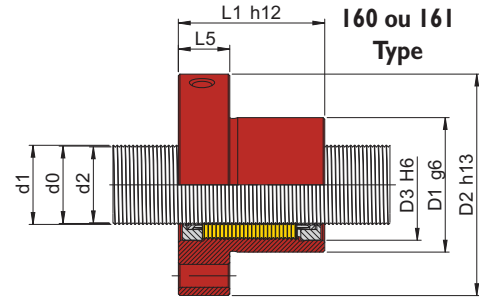
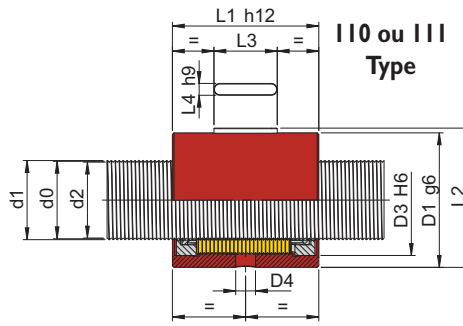
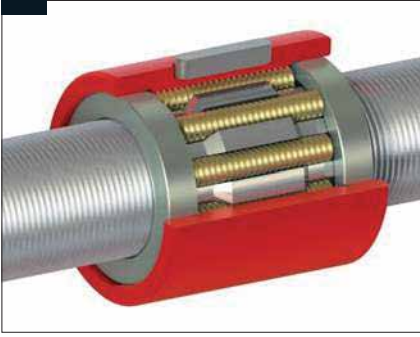

RVR Range

Types		TECHNICAL CHARACTERISTICS													DIRECT efficiency	INDIRECT efficiency
		D x P	N	Helix angle	SINGLE NUT				SPLIT NUT							
					Ca [kN]	C0a [kN]	Fk [N2/3µm]	Max axial backlash *	Ca [kN]	C0a [kN]	Fk [N2/3µm]	Fv [N]	Mv [Nm]			
RVR	8 x	0,25	1	0,58	7,3	14,3	40,5	0,02	4,2	7,1	25,5	820	0,06	0,58	0,29	
		0,5	1	1,17	8,7	13,5	27,4	0,02	5,0	6,8	17,3	790	0,06	0,73	0,63	
		1	1	2,39	11,8	14,3	18,9	0,03	6,8	7,2	11,9	730	0,06	0,83	0,80	
		2	2	4,77	11,8	14,3	18,9	0,03	6,8	7,2	11,9	550	0,06	0,88	0,87	
RVR	10 x	0,25	1	0,46	8,8	17,7	45,9	0,02	5,0	8,9	28,9	870	0,08	0,53	0,11	
		0,5	1	0,93	10,4	16,8	31,0	0,02	6,0	8,4	19,6	855	0,08	0,69	0,55	
		1	1	1,89	14,1	17,8	21,4	0,03	8,1	8,9	13,5	810	0,08	0,81	0,76	
		2	2	3,78	14,1	17,8	21,4	0,03	8,1	8,9	13,5	665	0,08	0,87	0,85	
RVR	12 x	0,25	1	0,38	10,1	21,2	51,0	0,02	5,8	10,6	32,1	910	0,10	0,51	0,02	
		0,5	1	0,77	11,9	20,1	34,5	0,02	6,8	10,0	21,7	895	0,10	0,65	0,46	
		1	1	1,57	16,1	21,3	23,8	0,03	9,3	10,6	15,0	860	0,10	0,78	0,72	
		2	2	3,13	16,1	21,3	23,8	0,03	9,3	10,6	15,0	740	0,10	0,86	0,84	
RVR	16 x	0,5	1	0,58	14,3	26,7	40,8	0,02	8,2	13,3	25,7	1 020	0,15	0,58	0,29	
		1	1	1,17	19,4	28,2	28,2	0,03	11,1	14,1	17,8	990	0,15	0,73	0,63	
		2	2	2,33	19,4	28,2	28,2	0,03	11,1	14,1	17,8	895	0,15	0,83	0,80	
RVR	20 x	0,5	1	0,46	19,5	45,5	53,6	0,02	11,2	22,7	33,8	1 090	0,20	0,53	0,11	
		1	1	0,93	27,1	49,7	37,5	0,03	15,6	24,8	23,7	1 070	0,20	0,69	0,55	
		2	2	1,86	27,1	49,7	37,5	0,03	15,6	24,8	23,7	995	0,20	0,80	0,76	
RVR	25 x	1	1	0,74	39,7	85,2	48,3	0,03	22,8	42,6	30,4	1 295	0,30	0,64	0,44	
		2	2	1,48	39,7	85,2	48,3	0,03	22,8	42,6	30,4	1 228	0,30	0,77	0,70	
RVR	32 x	1	1	0,58	60,8	148,9	61,0	0,03	34,9	74,4	38,4	1 698	0,50	0,58	0,29	
		2	1	1,15	60,8	148,9	61,0	0,03	34,9	74,4	38,4	1 635	0,50	0,73	0,63	
		4	2	2,33	73,5	144,7	42,6	0,03	42,2	72,4	26,8	1 493	0,50	0,83	0,80	
RVR	36 x	1	1	0,51	73,8	180,5	64,1	0,03	42,4	90,2	40,4	1 815	0,60	0,56	0,20	
		2	1	1,03	86,5	171,5	44,2	0,03	49,7	85,7	27,9	1 775	0,60	0,71	0,59	
RVR	40 x	1	1	0,46	79,8	206,9	69,5	0,03	45,8	103,5	43,8	1 908	0,70	0,53	0,11	
		2	1	0,92	79,8	206,9	69,5	0,03	45,8	103,5	43,8	1 857	0,70	0,69	0,54	
		4	2	1,86	97,3	199,0	47,7	0,03	55,9	99,5	30,0	1 740	0,70	0,80	0,76	

* Axial backlash can be reduced on demand.

Terms used in tables	N Number of starts	F_k Rigidity factor
P Lead (travel per revolution)	C_a Dynamic load capacity	F_v Preloading force
D Reference diameter	C_{0a} Static load capacity	M_v Preload torque

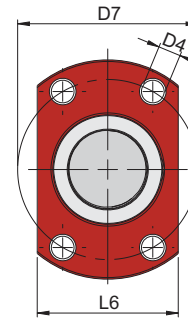
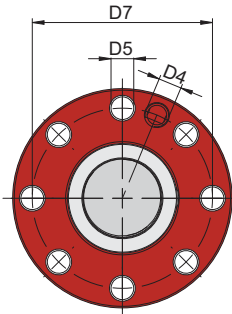
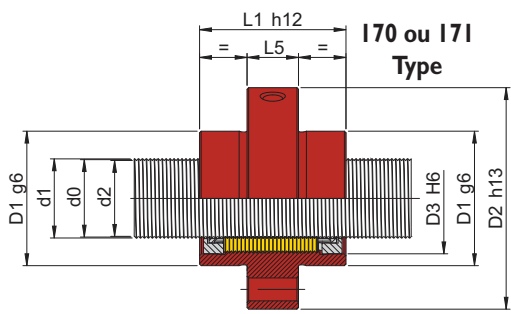
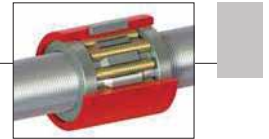

Types	SCREW						NUT											
		[mm]	[mm]	[mm]	[mm]	[mm]	[mm]	[mm]	[mm]	[mm]	Without wiper	With wipers	[mm]	[mm]	[mm]	[mm]	[mm]	
	D x P	Ø d1	Ø d0	Ø d2	Ø D1	Ø D2	Ø D3	D4	Ø D5	Ø D7	L1	L2	L3	L4	L5	L6		
RVR	8 x	0,25	7,91	7,80	20	43	17,0	5	M5	4,8	33	31	41	20,8	10	2	13	22
		0,5	7,82	7,60														
		1	7,63	7,19														
		2	7,63	7,19														
RVR	10 x	0,25	9,91	9,80	22	43	18,5	5	M5	4,8	33	31	41	22,8	12	2	13	24
		0,5	9,82	9,60														
		1	9,63	9,19														
		2	9,63	9,19														
RVR	12 x	0,25	11,91	11,80	24	46	20	5	M5	4,8	36	31	41	24,8	12	2	13	26
		0,5	11,82	11,60														
		1	11,63	11,19														
		2	11,63	11,19														
RVR	16 x	0,5	15,82	15,60	29	51	25	5	M6	4,8	41	31	41	30,2	12	3	13	31
		1	15,63	15,19														
		2	15,63	15,19														
RVR	20 x	0,5	19,82	19,60	34	58	28	5	M6	5,8	46	37	47	35,2	16	3	18	36
		1	19,63	19,19														
		2	19,63	19,19														
RVR	25 x	1	24,63	24,19	42	68	36	5	M6	5,8	56	44	54	43,5	20	4	18	44
		2	24,63	24,19														
RVR	32 x	1	31,63	31,19	53	83	46	5	M6	7,0	70	55	67	55,2	20	4	20	55
		2	31,63	31,19														
		4	31,26	30,38														
RVR	36 x	1	35,63	35,19	61	90	53	5	M6	9,0	75	62	75	63,7	28	6	17	63
		2	35,26	34,38														
RVR	40 x	1	39,63	39,19	70	104	58	5	M6	9,0	85	66	80	72,7	28	6	26	72
		2	39,63	39,19														
		4	39,26	38,38														

RVR Range

Terms used in tables
D Reference diameter **d0** Nominal diameter
P Lead (travel per revolution) **d1** External diameter **d2** Thread root diameter

RVR Range - Satellite roller screw - mechanism with recirculating rollers

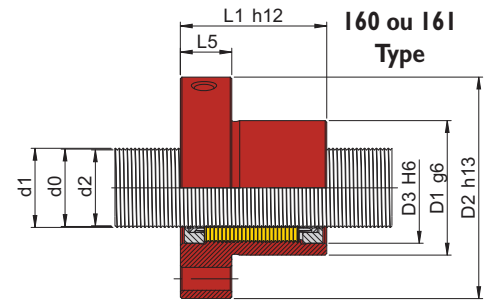
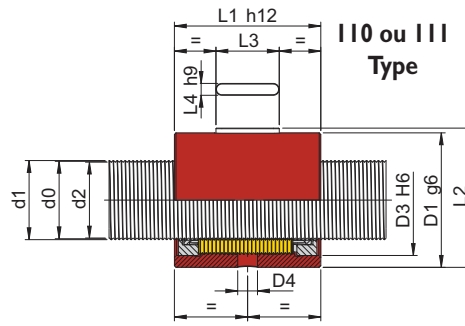
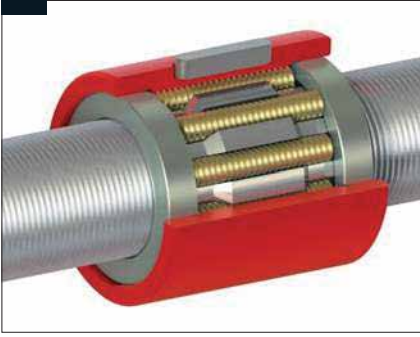

RVR Range

Types		TECHNICAL CHARACTERISTICS													
		SINGLE NUT							SPLIT NUT					DIRECT efficiency	INDIRECT efficiency
D x P	N	Helix angle	Ca [kN]	C0a [kN]	Fk [N2/3µm]	Max axial backlash *	Ca [kN]	C0a [kN]	Fk [N2/3µm]	Fv [N]	Mv [Nm]				
RVR	50 x	1	1	0,37	134,1	410,4	93,6	0,03	77,0	205,2	58,9	1969	0,90	0,52	0,06
		2		0,73	139,9	424,4	94,6	0,03	80,3	212,2	59,6	1930	0,90	0,64	0,44
		3	2	1,11	160,0	429,0	76,9	0,03	91,9	214,5	48,5	1888	0,90	0,72	0,62
		4		1,48	168,2	407,6	64,7	0,03	96,6	203,8	40,8	1842	0,90	0,77	0,70
RVR	63 x	2	1	0,59	219,6	563,0	73,6	0,03	126,1	281,5	46,3	2068	1,20	0,59	0,30
		3		0,88	241,4	534,1	58,2	0,03	138,7	267,0	36,7	2043	1,20	0,68	0,53
		4	2	1,17	219,6	563,0	73,6	0,03	126,1	281,5	46,3	1990	1,20	0,73	0,64
RVR	80 x	2	1	0,46	374,6	1393,4	115,8	0,05	215,2	696,7	73,0	/	/	0,53	0,11
		3		0,69	414,2	1361,1	93,4	0,05	237,9	680,5	58,8	/	/	0,63	0,40
		4		0,93	440,6	1326,1	80,5	0,05	253,0	663,1	50,7	/	/	0,69	0,55
RVR	100 x	3	1	0,55	512,0	1576,5	93,8	0,05	294,0	788,3	59,1	/	/	0,57	0,26
		4		0,74	523,3	1548,0	80,4	0,05	300,6	774,0	50,6	/	/	0,64	0,44
		5		0,93	527,5	1519,6	71,3	0,05	302,9	759,8	44,9	/	/	0,69	0,55
RVR	125 x	5	1	0,74	986,0	3972,5	111,5	0,05	566,3	1986,2	70,2	/	/	0,64	0,44

* Axial backlash can be reduced on demand.

Terms used in tables	N Number of starts	F_k Rigidity factor
P Lead (travel per revolution)	Ca Dynamic load capacity	F_v Preloading force
D Reference diameter	C0a Static load capacity	M_v Preload torque

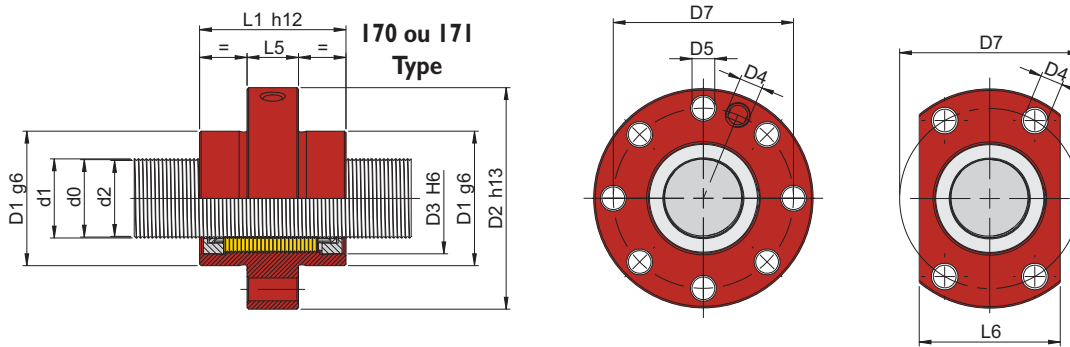
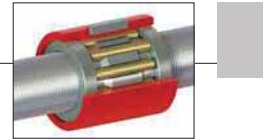

Types	D x P	SCREW					NUT												
		Ø d1	Ø d0	Ø d2	Ø D1	Ø D2	Ø D3	D4	Ø D5	Ø D7	Without wiper	With wipers	L2	L3	L4	L5	L6		
		[mm]	[mm]	[mm]	[mm]	[mm]	[mm]	[mm]	[mm]	[mm]	[mm]	[mm]	[mm]	[mm]	[mm]	[mm]	[mm]	[mm]	
RVR	50 x	1	50	49,63	49,19	82	124	74	8	M6	11,0	102	85	101	84,7	32	6	28	84
		2	49,63	49,19															
		3	49,45	48,79															
		4	49,26	48,38															
RVR	63 x	2	63	62,26	61,38	102	148	94	8	M8 x 1	13,5	127	110	124	104,7	40	6	32	104
		3	61,89	60,57															
		4	62,26	61,38															
RVR	80 x	2	80	79,26	78,38	140	198	115	10	M8 x 1	17,5	170	175	189	141,7	50	10	35	140
		3	78,89	77,57															
		4	78,52	76,76															
RVR	100 x	3	100	98,89	97,57	174	238	146	10	M8 x 1	17,5	210	180	196	173,7	56	12	40	172
		4	98,52	96,76															
		5	98,15	95,95															
RVR	125 x	5	125	123,15	120,95	220	310	188	15	M10 x 1	20,0	270	262	282	223	100	12	55	225

RVR Range

Terms used in tables
D Reference diameter **d0** Nominal diameter
P Lead (travel per revolution) **d1** External diameter **d2** Thread root diameter



RVD 42 x 0.1



RVD 60 x 0.6

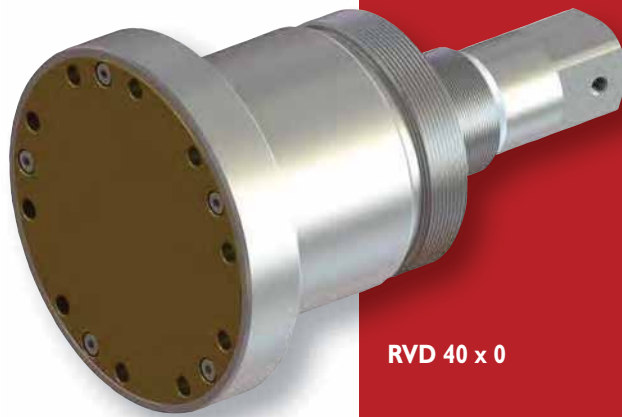

RVD 40 x 0

RVD Range - Differential roller screws



<i>Dimensions</i>	<i>pages</i>
● RVD 12 / 15 / 18	60
● RVD 21 / 24 / 27	61
● RVD 30 / 33	62
● RVD 36 / 39	63

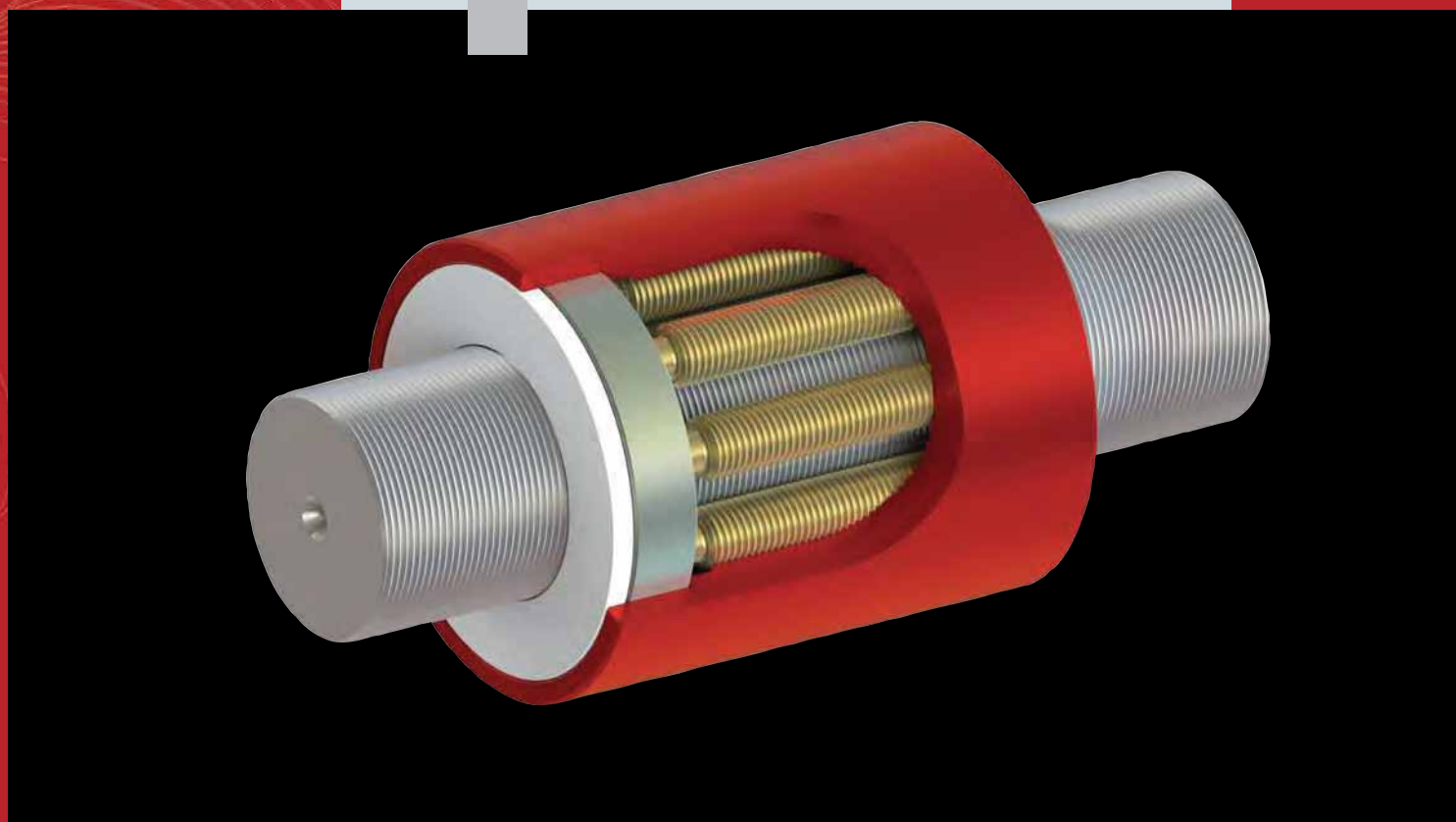

RVD Range

RVD Range - Differential roller screws

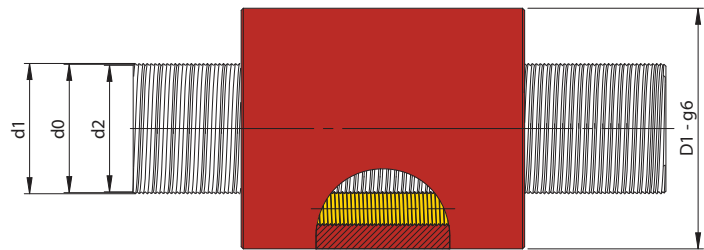
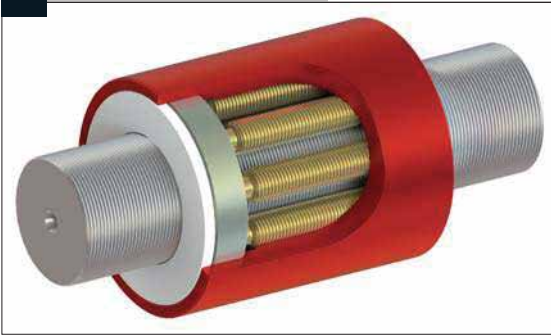

RVD Range

Types	TECHNICAL CHARACTERISTICS				SCREW			NUT
	D x P	SCREW			Ø d1	Ø d0	Ø d2	Ø DI
		Ca	C0a	Fk				
		[kN]	[kN]	[N2/3µm]	[mm]	[mm]	[mm]	[mm]
RVD	12 x	0,05	9,0	11,1	27,4	12,15	11,82	26
		0,10	14,2	22,2	43,5	12,15	11,82	
		0,15	15,6	21,9	34,9	12,23	11,73	
		0,20	16,6	21,6	29,9	12,30	11,64	
		0,25	18,0	22,6	27,3	12,38	11,56	
		0,30	13,1	15,1	23,6	12,30	11,64	
		0,35	15,2	24,4	46,4	12,15	11,82	
		0,40	12,3	17,8	37,5	12,15	11,82	
		0,45	12,6	17,7	35,2	12,17	11,80	
		0,50	15,5	19,4	27,9	12,30	11,64	
RVD	15 x	0,05	12,2	16,3	32,2	15,15	14,82	32
		0,10	19,4	32,6	51,1	15,15	14,82	
		0,15	21,6	32,8	41,5	15,23	14,73	
		0,20	23,2	33,0	35,7	15,30	14,64	
		0,25	24,9	33,7	32,2	15,38	14,56	
		0,30	18,3	23,1	28,2	15,30	14,64	
		0,35	20,6	35,9	54,4	15,15	14,82	
		0,40	16,7	26,1	44,0	15,15	14,82	
		0,45	17,1	25,8	41,2	15,17	14,80	
		0,50	21,7	29,7	33,3	15,30	14,64	
RVD	18 x	0,05	18,7	30,1	42,4	18,15	17,82	36
		0,10	29,7	60,3	67,4	18,15	17,82	
		0,15	33,0	60,5	54,4	18,23	17,73	
		0,20	35,6	60,7	46,8	18,30	17,64	
		0,25	37,8	60,9	41,7	18,38	17,56	
		0,30	28,1	42,5	36,9	18,30	17,64	
		0,35	31,6	66,3	71,8	18,15	17,82	
		0,40	25,6	48,2	58,1	18,15	17,82	
		0,45	26,3	47,8	54,1	18,17	17,80	
		0,50	33,2	54,6	43,7	18,30	17,64	

Terms used in tables

P Lead (travel per revolution)
D Reference diameter
Ca Dynamic load capacity

C0a Static load capacity
Fk Rigidity factor
d1 External diameter

d0 Nominal diameter
d2 Thread root diameter
DI Mini external diameter

RVD Range - Differential roller screws

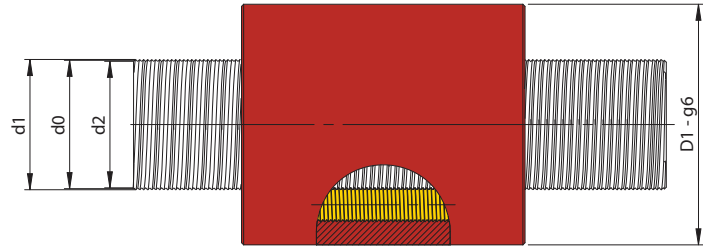
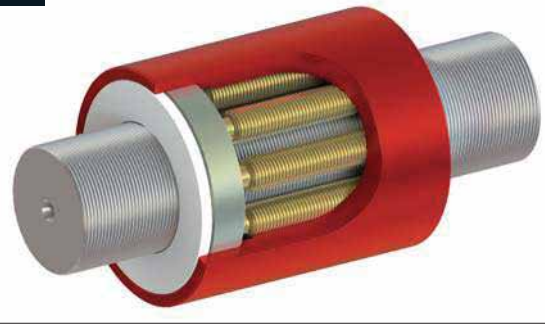

Types	TECHNICAL CHARACTERISTICS				SCREW			NUT
	D x P	[kN]	[kN]	[Nz/3µm]	[mm]	[mm]	[mm]	[mm]
		Ca	C0a	Fk	Ø d1	Ø d0	Ø d2	Ø DI
RVD	21 x	0,05	25,7	46,9	51,8	21,15	20,82	41
		0,10	40,8	93,7	82,2	21,15	20,82	
		0,15	45,1	93,1	65,7	21,23	20,73	
		0,20	48,4	92,5	56,5	21,30	20,64	
		0,25	52,2	95,3	50,9	21,38	20,56	
		0,30	38,2	64,8	44,6	21,30	20,64	
		0,35	43,4	103,1	87,6	21,15	20,82	
		0,40	35,1	75,0	70,9	21,15	20,82	
		0,45	36,0	74,4	66,2	21,17	20,80	
		0,50	45,1	83,3	52,7	21,30	20,64	
RVD	24 x	0,05	35,1	73,0	63,3	24,15	23,82	46
		0,10	55,7	146,0	100,5	24,15	23,82	
		0,15	61,5	144,3	80,0	24,23	23,73	
		0,20	66,9	146,6	69,5	24,30	23,64	
		0,25	70,9	146,8	61,9	24,38	23,56	
		0,30	52,8	102,6	54,8	24,30	23,64	
		0,35	59,4	160,6	107,1	24,15	23,82	
		0,40	48,0	116,8	86,6	24,15	23,82	
		0,45	49,1	115,3	80,8	24,17	23,80	
		0,50	62,4	131,9	64,8	24,30	23,64	
RVD	27 x	0,05	38,7	80,7	65,6	27,15	26,82	53
		0,10	61,5	161,4	104,1	27,15	26,82	
		0,15	68,4	161,7	83,8	27,23	26,73	
		0,20	73,8	162,0	71,9	27,30	26,64	
		0,25	78,6	163,4	64,4	27,38	26,56	
		0,30	58,2	113,4	56,7	27,30	26,64	
		0,35	65,5	177,5	110,9	27,15	26,82	
		0,40	53,0	129,1	89,7	27,15	26,82	
		0,45	54,8	129,8	84,6	27,17	26,80	
		0,50	68,8	145,8	67,0	27,30	26,64	

RVD Range

Terms used in tables	C0a Static load capacity	d0 Nominal diameter
P Lead (travel per revolution)	Fk Rigidity factor	d2 Thread root diameter
D Reference diameter	d1 External diameter	DI Mini external diameter
Ca Dynamic load capacity		

RVD Range - Differential roller screws

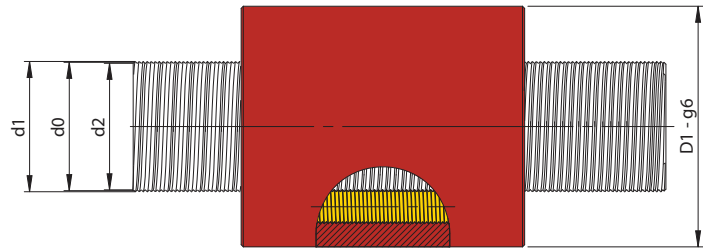
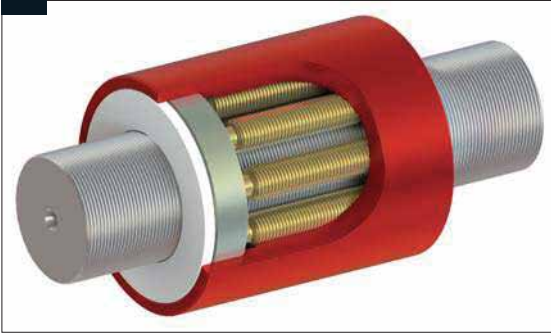

RVD Range

Types	TECHNICAL CHARACTERISTICS				SCREW			NUT
	D x P	[kN]	[kN]	[N2/3µm]	[mm]	[mm]	[mm]	[mm]
		Ca	C0a	Fk	Ø dI	Ø d0	Ø d2	Ø DI
RVD	30 x	0,05	46,8	104,1	73,6	30	29,82	60
		0,10	74,3	208,2	116,8		29,82	
		0,15	82,7	208,5	94,0		29,73	
		0,20	88,5	206,4	79,8		29,64	
		0,25	94,9	210,4	71,9		29,56	
		0,30	69,8	144,5	62,9		29,64	
		0,35	79,1	229,0	124,5		29,82	
		0,40	64,0	166,5	100,7		29,82	
		0,45	66,0	166,6	94,3		29,80	
		0,50	82,5	185,7	74,4		29,64	
RVD	33 x	0,05	42,7	84,3	66,3	33	32,82	67
		0,10	67,8	168,6	105,2		32,82	
		0,15	75,8	170,2	84,9		32,73	
		0,20	80,7	166,8	71,7		32,64	
		0,25	86,7	171,0	64,5		32,56	
		0,30	63,6	116,8	56,5		32,64	
		0,35	72,2	185,4	112,1		32,82	
		0,40	58,4	134,9	90,7		32,82	
		0,45	60,1	134,4	84,9		32,80	
		0,50	75,2	150,1	66,8		32,64	

Terms used in tables

P Lead (travel per revolution)
D Reference diameter
Ca Dynamic load capacity

C0a Static load capacity
Fk Rigidity factor
dI External diameter

d0 Nominal diameter
d2 Thread root diameter
DI Mini external diameter

RVD Range - Differential roller screws

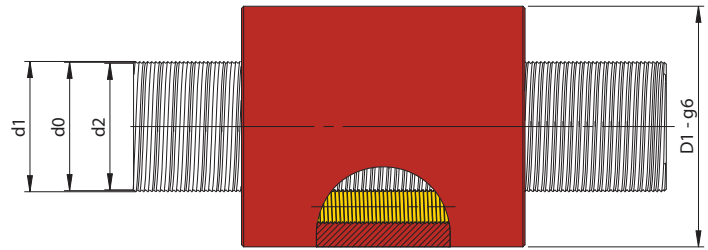
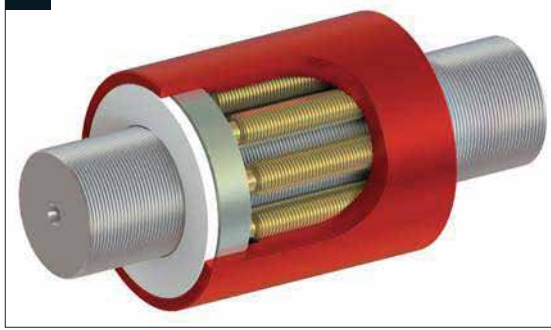

Types	TECHNICAL CHARACTERISTICS				SCREW			NUT	
	D x P	[kN]	[kN]	[Nz/3µm]	[mm]	[mm]	[mm]	[mm]	
		Ca	C0a	Fk	Ø d1	Ø d0	Ø d2	Ø DI	
RVD	36 x	0,05	45,4	88,3	67,4	36	35,82	74	
		0,10	72,0	176,6	107,1		35,82		
		0,15	80,5	178,3	86,4		36,23		35,73
		0,20	85,7	174,7	73,1		36,30		35,64
		0,25	92,1	179,2	65,5		36,38		35,56
		0,30	67,6	122,3	57,7		36,30		35,64
		0,35	76,7	194,2	114,1		36,15		35,82
		0,40	62,1	141,2	92,3		36,15		35,82
		0,45	63,9	140,8	86,5		36,17		35,80
		0,50	79,9	157,3	68,2		36,30		35,64
RVD	39 x	0,05	67,2	164,4	89,5	39	38,82	82	
		0,10	106,7	328,9	142,1		39,15		38,82
		0,15	118,1	326,2	113,4		39,23		38,73
		0,20	127,4	326,6	97,5		39,30		38,64
		0,25	136,0	330,2	86,4		39,38		38,56
		0,30	100,5	228,6	76,9		39,30		38,64
		0,35	113,7	361,8	151,4		39,15		38,82
		0,40	92,0	263,1	122,5		39,15		38,82
		0,45	94,3	260,7	114,6		39,17		38,80
		0,50	118,8	293,9	90,9		39,30		38,64

RVD Range

Terms used in tables	C0a Static load capacity	d0 Nominal diameter
P Lead (travel per revolution)	Fk Rigidity factor	d2 Thread root diameter
D Reference diameter	d1 External diameter	DI Mini external diameter
Ca Dynamic load capacity		

Bearing units for satellite roller screws - Standard types of assembly available

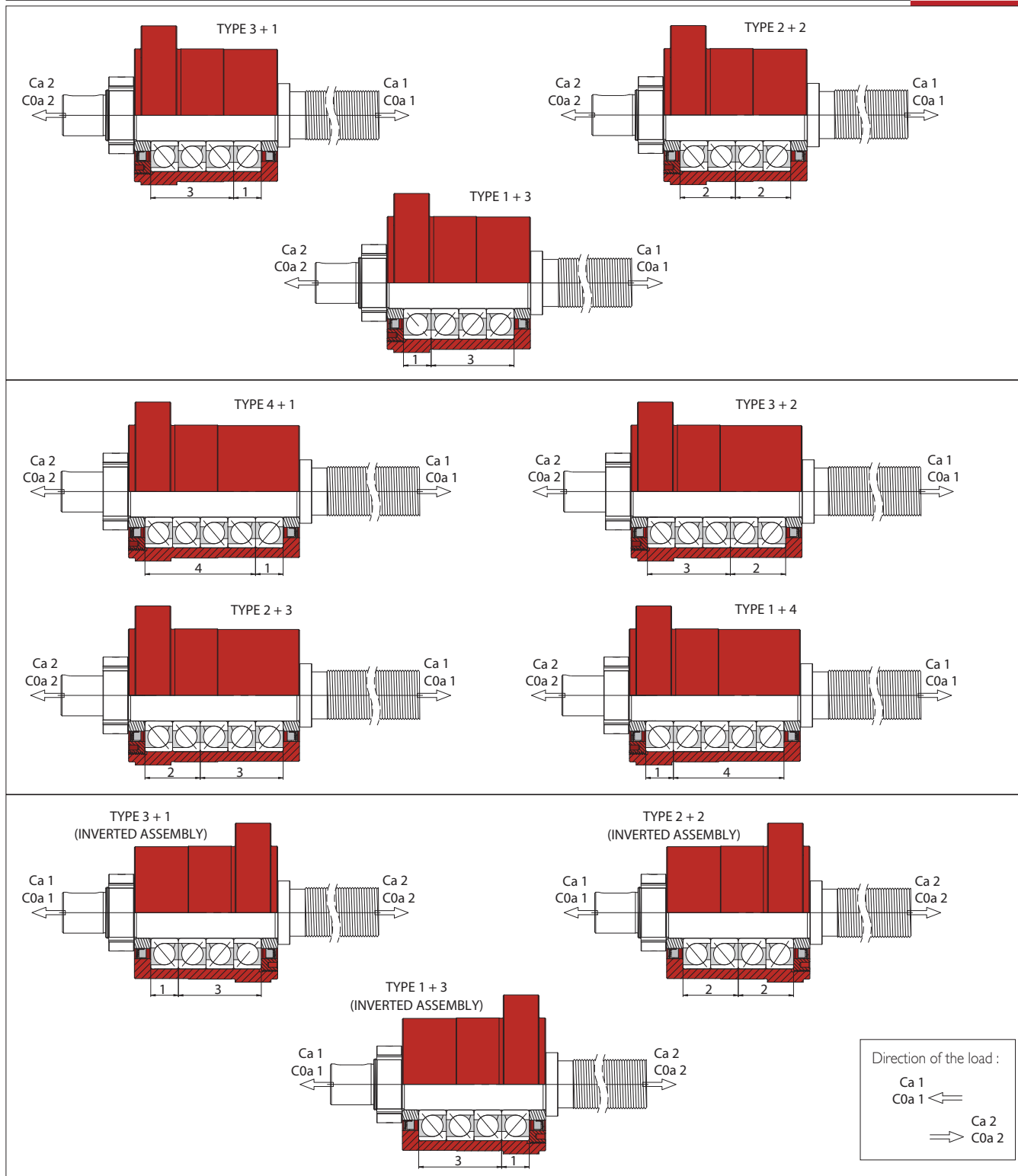

Nominal fatigue lifetime for axial loaded bearings:

$$L_{10} = \left(\frac{C_a}{F_m} \right)^3 \text{ revolutions} \quad \text{Respectively} \quad L_h = \frac{L_{10}}{n_m \cdot 60} [h]$$

Nominal fatigue lifetime for the bearing unit:

All bearing units are preloaded to ensure optimal support. When loads are applied in the two different axial directions, bearing unit lifetime calculation depends on average axial forces F_m (considering preload) and on the equivalent dynamic capacity of each set of bearings assembled in the same direction. As a result, with the two lifetime values $L_{10(1)}$ and $L_{10(2)}$ (revolutions), we can calculate the global bearing unit lifetime.

$$L_{10(1)} = \left(\frac{C_{a1}}{F_{ma(1)}} \right)^3 \cdot 10^6 \text{ revolutions} \quad L_{10(2)} = \left(\frac{C_{a2}}{F_{ma(2)}} \right)^3 \cdot 10^6 \text{ revolutions} \quad L_{10} = \left(L_{10(1)}^{-10/9} + L_{10(2)}^{-10/9} \right)^{-9/10} \text{ revolutions}$$

BU - Bearing units for roller screws



Type	pages
● BU 1 / 2 / 3 / 4 / 5 / 6 / 6L / 7 / 7L	66
● BU 8 / 8L / 9 / 9XL	67
● Shaft ends dimensions	68



Bearing units **BU**

BU - Bearing units for roller screws

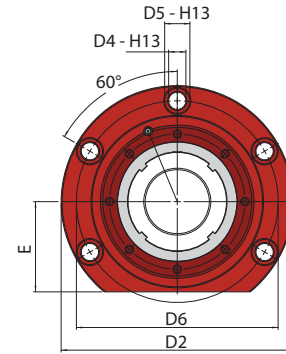
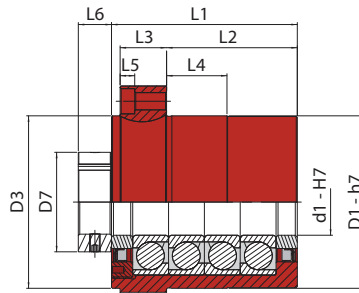

HOUSING		Bearings arrangement Types	DIMENSIONS														EQUIVALENT AXIAL LOAD RATINGS					
Family	n°		[mm]	[mm]	[mm]	[mm]	[mm]	[mm]	[mm]	[mm]	[mm]	[mm]	[mm]	[mm]	[mm]	[mm]	[mm]	[kN]	[kN]	[kN]	[kN]	[Nm]
			∅ d1	∅ D1	∅ D2	∅ D3	∅ D4	∅ D5	∅ D6	∅ D7	L1	L2	L3	L4	L5	L6	E	Capacities* depending on load direction				Mv
																	Ca 1	C0a 1	Ca 2	C0a 2		
BU	1	1 + 1	12	47	76	50	6,6	11	63	22	42	25	12	12	2	8	27	13,0	13,7	13,0	13,7	15
BU	2	1 + 1	17	60	90	62	6,6	11	76	28	46	32	12	18	2	10	32	24,9	27,7	24,9	27,7	22
BU	3	1 + 3	20	60	90	58	9	14	74	38	77	60	15	30	2	20	32	24,6	30,0	53,0	90,0	27
		2 + 2																39,9	60,0	39,9	60,0	
		3 + 1																53,0	90,0	24,6	30,0	
BU	4	1 + 3	25	80	120	80	11	17	100	45	89	68	19	36	3	20	44	49,1	60,8	106,0	182,3	38
		2 + 2																79,8	121,5	79,8	121,5	
		3 + 1																106,0	182,3	49,1	60,8	
BU	5	1 + 3	35	100	142	99	13	19	120	58	110	82	25	47	5	22	54	75,4	105,8	162,8	317,3	65
		2 + 2																122,6	211,5	122,6	211,5	
		3 + 1																162,8	317,3	75,4	105,8	
BU	6	1 + 3	50	130	175	130	13	19	152	75	140	98,5	37	58,5	12	25	67	131,6	192,3	283,9	576,9	110
		2 + 2																213,8	384,6	213,8	384,6	
		3 + 1																283,9	576,9	131,6	192,3	
	6L	1 + 4									131,6	192,3	347,2	769,2								
		2 + 3									213,8	384,6	283,9	576,9								
		3 + 2									283,9	576,9	213,8	384,6								
		4 + 1									347,2	769,2	131,6	192,3								
BU	7	1 + 3	65	170	227	170	17	25	198	105	180	133,5	42	53,5	12	32	87	193,0	315,4	416,4	946,2	200
		2 + 2																313,5	630,8	313,5	630,8	
		3 + 1																416,4	946,2	193,0	315,4	
	7L	1 + 4									193,0	315,4	509,3	1 261,5								
		2 + 3									313,5	630,8	416,4	946,2								
		3 + 2									416,4	946,2	313,5	630,8								
		4 + 1									509,3	1 261,5	193,0	315,4								

* See types of bearings arrangement and the legend, page 64

Terms used in tables	Mv Preload torque
Ca Dynamic load capacity	d1 Shaft diameter (bearing unit bore)
C0a Static load capacity	D1 Housing external diameter

BU - Bearing units for roller screws

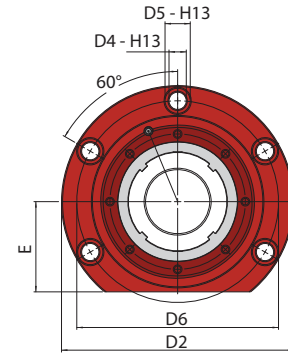
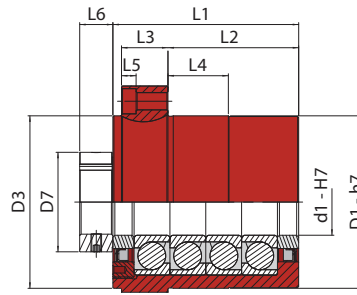

HOUSING		Bearings arrangement Types	DIMENSIONS													EQUIVALENT AXIAL LOAD RATINGS						
Family	n°		[mm]	[mm]	[mm]	[mm]	[mm]	[mm]	[mm]	[mm]	[mm]	[mm]	[mm]	[mm]	[mm]	[mm]	[mm]	[kN]	[kN]	[kN]	[kN]	[Nm]
			∅ dI	∅ DI	∅ D2	∅ D3	∅ D4	∅ D5	∅ D6	∅ D7	L1	L2	L3	L4	L5	L6	E	Ca 1	C0a 1	Ca 2	C0a 2	Mv
BU	8	1 + 3															315,8	596,2	681,4	1 788,5	300	
		2 + 2								235	179						513,0	1 192,3	513,0	1 192,3		
		3 + 1															681,4	1 788,5	315,8	596,2		
	8L	1 + 4	90	220	290	216	22	32	252	130			50	99	15	38	115	315,8	596,2	833,4		2 384,6
		2 + 3									278	222						513,0	1 192,3	681,4		1 788,5
		3 + 2																681,4	1 788,5	513,0		1 192,3
	4 + 1																833,4	2 384,6	315,8	596,2		
BU	9	1 + 3															375,4	757,7	810,1	2 273,1	400	
		2 + 2								253	195						609,9	1 515,4	609,9	1 515,4		
		3 + 1															810,1	2 273,1	375,4	757,7		
	9XL	1 + 5	100	250	327	243	25	38	285	140			52	115	16	38	130	375,4	757,7	1 158,3		3 788,5
		2 + 4																609,9	1 515,4	990,8		3 030,8
		3 + 3									347	289						810,1	2 273,1	810,1		2 273,1
		4 + 2																990,8	3 030,8	609,9		1 515,4
		5 + 1																1 158,3	3 788,5	375,4		757,7

* See types of bearings arrangement and the legend, page 64

Terms used in tables
Ca Dynamic load capacity
C0a Static load capacity
Mv Preload torque
dI Shaft diameter (bearing unit bore)
DI Housing external diameter

Bearing units BU

End shafts dimensions

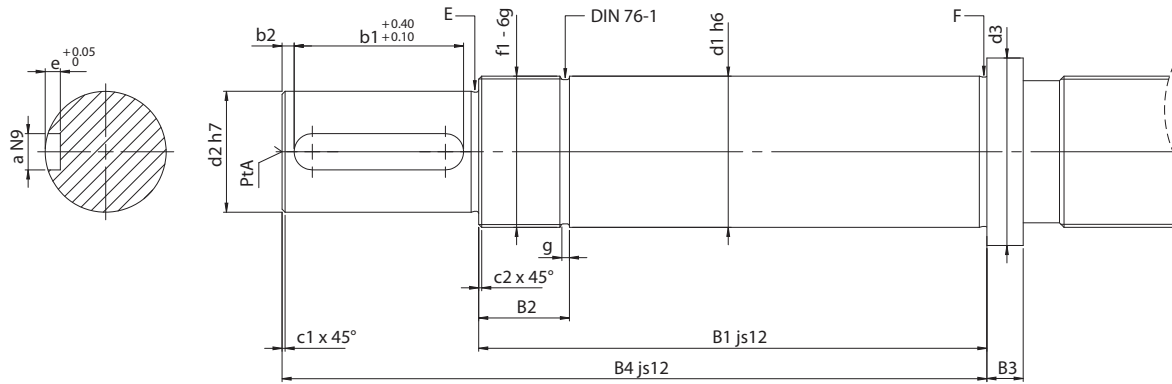

HOUSING		END SHAFTS DIMENSIONS																	
Family	n°	[mm]	[mm]	[mm]	[mm]	[mm]	[mm]	[mm]	[mm]	[mm]	[mm]	[mm]	[mm]	[mm]	[mm]	[mm]	[mm]	[mm]	[mm]
		∅ d1	∅ d2	∅ d3	B1	B2	B3	B4	∅ f1	c1	c2	g	E	F	b1	b2	a	e	Pta
BU	1	12	10	17	51	10	5	71	M12 x 1	0,5	0,7	1,5	0,4 x 0,2	0,4 x 0,3	16	1,5	3	1,8	1,6 - 3,35
BU	2	17	15	23	66	21	5	96	M17 x 1	0,5	0,7	1,5	0,6 x 0,2	0,6 x 0,2	25	2	5	3	2 - 4,25
BU	3	20	17	27	98	22	7	138	M20 x 1	0,5	0,7	1,5	0,6 x 0,2	0,6 x 0,2	32	3	5	3	2 - 4,25
BU	4	25	20	34	111	24	7	156	M25 x 1,5	0,5	1	2,5	0,6 x 0,2	0,6 x 0,2	40	2,5	6	3,5	2,5 - 5,3
BU	5	35	30	45	134	26	10	189	M35 x 1,5	1	1	2,5	0,6 x 0,2	0,6 x 0,2	45	2,5	8	4	3,15 - 6,7
BU	6	50	40	62	168	30	12	233	M50 x 1,5	1	1	2,5	0,8 x 0,3	0,8 x 0,3	56	4	12	5	3,15 - 6,7
	6L				195			260											
BU	7	65	60	78	215	37	18	315	M65 x 2	1	1,5	4	1 x 0,4	1,6 x 0,3	90	3	18	7	4 - 8,5
	7L				248			348											
BU	8	90	85	108	275	43	25	395	M90 x 2	1	1,5	4	1,6 x 0,3	1,6 x 0,3	100	8	25	9	6,3 - 13,2
	8L				318			438											
BU	9	100	95	120	293	43	25	433	M100 x 2	1	1,5	4	1,6 x 0,3	1,6 x 0,3	125	7	25	9	6,3 - 13,2
	9XL				387			527											

Bearing units BU



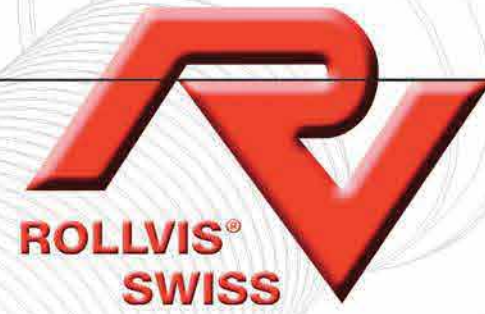

SATELLITE ROLLER SCREWS



After its founding in 1970, ROLLVIS SA soon began to focus on the manufacturing and marketing of satellite roller screws under the trademark « Rollvis swiss ». Now a benchmark in this highly specialised field, ROLLVIS SA has invested in the most powerful machines for the production of very high accuracy screws with low tolerance margins designed to applications specifications. Still a fast-growing company with lots of expertise qualified workforce, ROLLVIS SA owns ultra-modern premises near to Geneva, in the Plan-les Ouates' Business Park. It is organized to preserve its human scale and its capacity to listen and adapt perfectly to its customers' requirements. Almost five decades of skills and experience combined with the latest high-end techniques ensure its products comply with the most stringent and demanding standards, notably in the following applications:



Roller screw expertise for aeronautics, space and Defense industry



Optronics and Mechatronics
Lifting Equipment and positioning systems
Special machines



Aircrafts
Helicopters
Unmanned vehicles
Launchers
Flight controls



Satellites
Telescops
Landing gears
Actuators
Defense

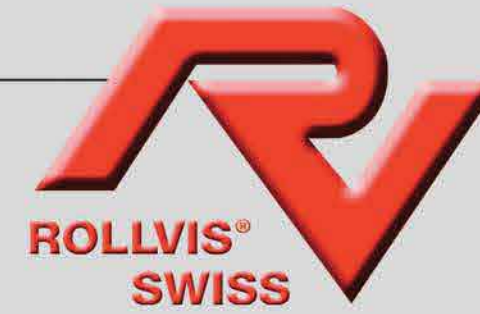

Today ROLLVIS is certified

ISO 9001 : 2015

EN 9100 : 2016

Certification



Application data list for roller screws

Operation conditions :

Number of screws supporting the lead :

Max static load :

Max. dynamic load :

Typical load chart (function of the stroke, forward and reverse stroke) :



Maximal linear speed of the application :

Stroke :

length of screw :

Main load : Compression

Tension

Rotation : Nut

Screw shaft

Positioning of the screw : Vertical

Horizontal

Specific limitations : Vibration :

Shocks :

Expected lifetime Nb of cycles :

Total time required - years-month :

Environnement : Humidity / Fluid / Dust :

Temperature range :

Geometric limitations : Nut/Shaft max diameter/Length :

Interfaces :

Motor torque :

Lubrication requirement :

Preload - Backlash - Accuracy - Stiffness :

Lead accuracy : G5 (23_m/300mm) G3 (12_m/300mm) G1 (6_m/300mm)

Manufacturing tolerances (ISO 3408-3) : Classe 5 Classe 3 Classe 1

Axial backlash : Standard Without backlash Preloading/Stiffness

Nut : Flange Cylindrical Double Specific design

Mounting conditions of the roller screw

Fixed - Free : XX —

Fixde - Supported : XX — X

Fixed - Fixed : XX — XX

Supported - Supported : X — X

Notes / Remarks / Sketch :



Conversion tables

LENGTH			
mm	m	inches	feet
1	0.001	0.0394	0.0033
1000	1	39.3701	3.2808
25.4	0.0254	1	0.0833
304.8	0.3048	12	1

SURFACE				
m ²	cm ²	mm ²	sq.in	sq.ft
1	10000	1000000	1550	10.76
0.0001	1	100	0.155	0.0011
0.000001	0.01	1	0.00155	1.076E-05
0.0006	6.4516	645.16	1	0.0069
0.0929	929.0304	92903.04	144	1

VOLUME							
m ³	dm ³ (liter)	cm ³	mm ³	in ³	ft ³	gallons (US)	fl oz
1	1000	1000000	1000000000	61.0237441	35.3147	264.1700	3381.37
0.001	1	1000	1000000	61.0237	0.0353	0.2642	33.8137
0.000001	0.001	1	1000	0.0610	3.53147E-05	0.0003	0.0338
0.000000001	0.000001	0.001	1	6.10237E-05	3.53147E-08	2.6417E-07	3.38137E-05
1.63871E-05	0.0164	16.3871	16.3870640	1	0.0006	0.0043	0.5541
0.028316847	28.3168	28.316	28.316.846.5920	1.12280000	1	7.4805	957.4974
0.003785441	3.7854	3.7854	3.785.441.2800	0.2310018	0.1337	1	127.9998
2.95738E-05	0.0296	29.57	29.573.8118	1.8047	0.0010	0.0078	1

LOAD				
N	kN	Tonf	kgf	Lbf
1	0.001	0.0001	0.1020	0.2248
1000	1	0.1020	101.9716	224.8090
9806.65	9.8067	1	1000	2.204.6234
9.8067	0.0098	0.001	1	2.2046
4.4482	0.0044	0.0005	0.4536	1

TORQUE							
Nm	Ncm	Nmm	daN.m	daN.cm	kgf.cm	in.lbf	ft.lbf
1	100	1000	0.1	10	10.1972	8.8507	0.7376
0.01	1	10	0.001	0.1	0.1020	0.0885	0.0074
0.001	0.1	1	0.0001	0.01	0.0102	0.0089	0.0007
10	1000	10000	1	100	101.9716	88.5075	7.3756
0.1	10	100	0.01	1	1.0197	0.8851	0.0738
0.0981	9.8067	98.0665	0.0098	0.9807	1	0.8680	0.0723
0.1130	11.2985	112.9848	0.0113	1.1298	1.1521	1	0.0833
1.3558	135.5817	1355.8175	0.1356	13.5582	13.8255	12	1

STIFFNESS		
N/mm	N/μm	lbf/in x 1E6
1	1000	5.7101
0.001	1	0.0057
0.1751	175.1268	1

LINEAR SPEED								
m/s	mm/s	m/min	km/h	in/s	in/min	ft/s	ft/min	mph
1	1000	60	3.6	39.3701	2.362.2047	3.2808	196.8504	2.2369
0.001	1	0.06	0.0036	0.0394	2.3622	0.0033	0.1969	0.0022
0.0167	16.6667	1	0.06	0.6562	39.3701	0.0547	3.2808	0.0373
0.2778	277.7778	16.6667	1	10.9361	656.1680	0.9113	54.6807	0.6214
0.0254	25.4	1.524	0.0914	1	60	0.0833	5	0.0568
0.0004	0.4233	0.0254	0.0015	0.0167	1	0.0014	0.0833	0.0009
0.3048	304.8	18.288	1.0973	12	720	1	60	0.6818
0.00508	5.08	0.3048	0.0183	0.2	12	0.0167	1	0.0114
0.4470	447.0389	26.8223	1.6093	17.6000	1.055.9974	1.4667	87.9998	1

VIS À ROULEAUX SATELLITES



SATELLITE ROLLER SCREWS

catalogue 2019



ROLLVIS SA

136, ch. du Pont-du-Centenaire
CH-1228 Plan-les-Ouates
GENEVA - SWITZERLAND
Correspondence: post box 590
CH - 1212 GRAND-LANCY 1

Tél. +41 (0)22 706 90 40
Fax +41 (0)22 706 90 49

Email : info@rollvis.com
Website: www.rollvis.com

catalogue 2019

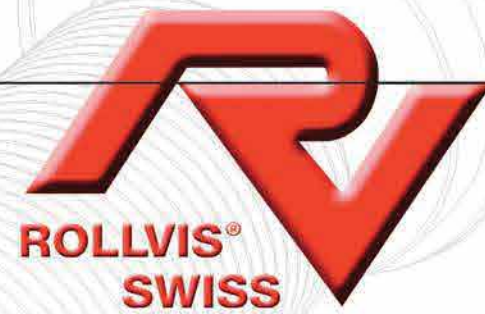

SATELLITE ROLLER SCREWS



Established in 1970, ROLLVIS SA quickly started to focus exclusively on design, manufacturing and marketing of satellite roller screws under the trademark «Rollvis swiss». Our products represent today the reference for high performance linear motion applications. Our factory is equipped with the most powerful machines to achieve to lowest tolerances on roller screws from very small quantities to larger batches. Following a continuous improvement path, Rollvis SA never stopped in investing in new manufacturing technologies and and skills in business park of Plan-les-Ouates in Geneva. The Rollvis high tech spirit and the scale of the company have always been preserved to ensure the best reactivity, flexibility and support to customer requirements. Five decades of experience combined with the latest technologies enable Rollvis screws to be the preferred choice in many demanding or complex applications for industrial, aerospace or defense applications and for any segment where the best is required.



Roller screw expertise for a aeronautics, space and Defense industry



Optronics and Mechatronics
Lifting Equipment and positioning systems
Special machines



Aircrafts
Helicopters
Unmanned vehicles
Launchers
Flight controls



Satellites
Telescops
Landing gears
Actuators
Defense

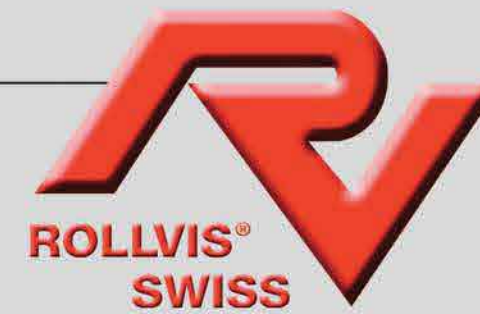

Today ROLLVIS is certified

ISO 9001 : 2015

EN 9100 : 2016

Certification



Application data list for roller screws

Operation conditions :

Number of screws supporting the lead :

Max static load :

Max. dynamic load :

Typical load chart (function of the stroke, forward and reverse stroke) :



Maximal linear speed of the application :

Stroke :

length of screw :

Main load : Compression

Tension

Rotation : Nut

Screw shaft

Positioning of the screw : Vertical

Horizontal

Specific limitations : Vibration :

Shocks :

Expected lifetime Nb of cycles :

Total time required - years-month :

Environnement : Humidity / Fluid / Dust :

Temperature range :

Geometric limitations : Nut/Shaft max diameter/Length :

Interfaces :

Motor torque :

Lubrication requirement :

Preload - Backlash - Accuracy - Stiffness :

Lead accuracy : G5 (23_m/300mm) G3 (12_m/300mm) G1 (6_m/300mm)

Manufacturing tolerances (ISO 3408-3) : Classe 5 Classe 3 Classe 1

Axial backlash : Standard Without backlash Preloading/Stiffness

Nut : Flange Cylindrical Double Specific design

Mounting conditions of the roller screw

Fixed - Free : XX —

Fixe - Supported : XX — X

Fixed - Fixed : XX — XX

Supported - Supported : X — X

Notes / Remarks / Sketch :

Conversion tables

LENGTH			
mm	m	inches	feet
1	0.001	0.0394	0.0033
1000	1	39.37	3.28
25.4	0.0254	1	0.083
304.8	0.305	12	1

SURFACE				
m ²	cm ²	mm ²	sq.in	sq.ft
1	10000	1000000	1550	10.76
0.0001	1	100	0.155	0.0011
0.000001	0.01	1	0.00155	1.076E-05
0.0006	6.45	645.2	1	0.0069
0.0929	929.03	92903	144	1

VOLUME							
m ³	dm ³ (liter)	cm ³	mm ³	in ³	ft ³	gallons (US)	fl oz
1	1000	1000000	1000000000	61 023.74	35.31	264.17	33813.7
0.001	1	1000	1000000	61.02	0.035	0.264	33.81
0.000001	0.001	1	1000	0.06	3.53-05	0.0003	0.034
0.000000001	0.000001	0.001	1	6.1-05	3.53-08	2.64-07	3.38-05
1.64-05	0.0164	16.387	16 387	1	0.0006	0.0043	0.5541
0.0283	28.3	28 316	28 316 846.59	1 728	1	7.48	95.749
0.003785	3.785	3 785	3 785 441.28	231.001	0.13	1	127.99
2.96	0.0296	29.57	29 573.8	1.8	0.001	0.0078	1

LOAD				
N	kN	Tonf	kgf	Lbf
1	0.001	0.0001	0.102	0.225
1000	1	0.102	101.97	224.8
9806.7	9.8067	1	1000	2 204.6
9.81	0.0098	0.001	1	2.205
4.45	0.0044	0.0005	0.45	1

TORQUE							
Nm	Ncm	Nmm	daN.m	daN.cm	kgf.cm	in.lbf	ft.lbf
1	100	1000	0.1	10	10.197	8.85	0.7376
0.01	1	10	0.001	0.1	0.102	0.0885	0.0074
0.001	0.1	1	0.0001	0.01	0.0102	0.0089	0.0007
10	1000	10000	1	100	101.9716	88.5	7.3756
0.1	10	100	0.01	1	10.197	8.85	0.7378
0.098	9.807	98.07	0.0098	0.98	1	0.868	0.0723
0.113	11.29	112.985	0.0113	1.129	1.152	1	0.0833
1.3558	135.58	1 355.8	0.1356	13.56	13.83	12	1

STIFFNESS		
N/mm	N/μm	lbf/in x 1E6
1	1000	5.71
0.001	1	0.0057
0.1751	175.13	1

LINEAR SPEED								
m/s	mm/s	m/min	km/h	in/s	in/min	ft/s	ft/min	mph
1	1000	60	3.6	39.37	2 362.2	3.28	196.85	2.237
0.001	1	0.06	0.0036	0.039	2.36	0.0033	0.197	0.0022
0.016	16.66	1	0.06	0.66	39.37	0.0547	3.28	0.0373
0.2778	277.77	16.66	1	10.936	656.168	0.91	54.68	0.62
0.0254	25.4	1.52	0.09	1	60	0.08	5	0.0568
0.0004	0.42	0.025	0.0015	0.0167	1	0.0014	0.083	0.0009
0.305	304.8	18.23	1.097	12	720	1	60	0.68
0.00508	5.08	0.305	0.018	0.2	12	0.0167	1	0.011
0.447	447.04	26.82	1.6	17.6	1 055.997	1.466	87.99	1

SATELLITE ROLLER SCREWS

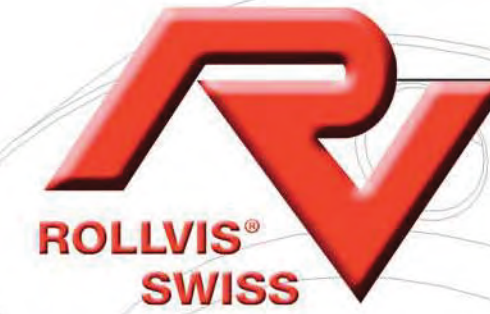
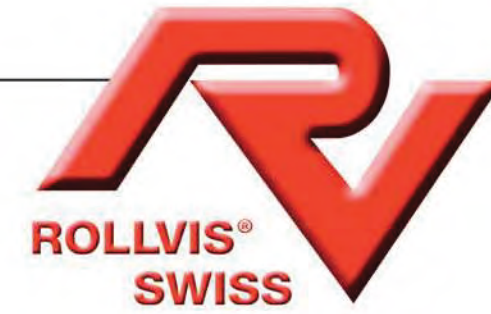

SATELLITE ROLLER SCREWS

catalogue 2019



ROLLVIS SA

136, ch. du Pont-du-Centenaire
CH-1228 Plan-les-Ouates
GENEVA - SWITZERLAND
Correspondence: post box 590
CH - 1212 GRAND-LANCY 1

Tél. +41 (0)22 706 90 40
Fax +41 (0)22 706 90 49

Email : info@rollvis.com
Website: www.rollvis.com

catalogue 2019