



# Safety Manual

TECHMAN ROBOT Safety System 3.2

Document version: 1.01

Release date: 2020-03-05

Original Instruction

This Manual contains information of the Techman Robot product series (hereinafter referred to as the TM Robot). The information contained herein is the property of Techman Robot Inc. (hereinafter referred to as the Corporation) and shall not be reproduced in whole or in part without prior authorization from the Corporation. No information contained herein shall be considered an offer or commitment. The information herein is subject to change without notice. The document is periodically reviewed and revised. The Corporation assumes no responsibility for any errors or omissions in the documentation.

**TM** logo is registered trademark of TECHMAN ROBOT INC. in Taiwan and other countries and the company reserves the ownership of this manual and its copy and its copyrights.

## Table of Contents

Revision History Table.....	5
1. Comprehensive Information.....	6
1.1 Overview.....	6
1.2 Applicable Product Version.....	6
1.3 Safety Warning Symbols.....	6
1.4 Safety Precautions.....	7
1.5 Validation and Responsibility.....	8
1.6 Limitation of Liability.....	8
1.7 Overall Safety Warning.....	8
1.8 Intended Use.....	10
1.9 Risk Assessment.....	11
2. Safety Function.....	13
2.1 Overview.....	13
2.2 General Information.....	13
2.2.1 Safety Function Definitions.....	13
2.2.2 Stopping Time and Stopping Distance in the Safety System.....	14
2.2.3 Software Safety Setting Permissions.....	14
2.3 Explanation of Safety Functions.....	14
2.3.1 SF0 Robot Stick ESTOP and SF1 User Connected ESTOP Input.....	14
2.3.2 SF2 Encoder Standstill.....	16
2.3.3 SF3 User Connected External Safeguard Input and SF9 User Connected External Safeguard Input for Human-Machine Safety Settings.....	16
2.3.4 SF4~SF8 Defined Safety Functions.....	17
2.3.5 SF10~SF14 Safety Output Functions.....	19
2.3.6 SF15 and SF16 Safety Input Functions.....	21
2.3.7 SF17 Cartesian Limit.....	23
3. Safety Related Operation.....	24
3.1 Joint Movement without Drive Power.....	24
3.1.1 During an Emergency Stop Procedure.....	24
3.1.2 Extending the Robot from the Packing Pose.....	24
3.1.3 Power Loss.....	24
3.2 Operation Mode and Mode Switching.....	25
3.2.1 Auto Mode.....	25
3.2.2 Manual Mode.....	25
3.2.3 Switch Between Modes.....	26

3.3 Hold to Run .....	26
3.4 Singularity Point .....	27
3.5 Replacing the Robot Stick in Local Control .....	31
4. Compliance of Safety Regulations .....	32
4.1 Compliance .....	32
4.1.1 Requirement of Enabling Device.....	32
4.1.2 Access of Safety Setting .....	32
5. Declaration of Incorporation .....	33
Appendix A. Certificate of Compliance and Declaration of Incorporation .....	36
Appendix B. Verifications of EMC Compliance .....	40
Appendix C. TM Robot Stopping Time and Distance for all Series Product Models .....	42

## Tables

Table 1: Safety System Version .....	6
Table 2: Safety Warning Symbols .....	7
Table 3: Safety Function Definitions .....	13
Table 4: Stop Category and Action of Fault Detection of SF0 and SF1 .....	15
Table 5: Stop Category and Action of Fault Detection of SF3 and SF9 .....	17
Table 6: SF4~SF8 Defined Safety Functions .....	18
Table 7: Stop Category and Reaction of Fault Detection of SF4~SF8 .....	18
Table 8: Output Signal and Action of Fault Detection of SF10~SF14.....	20
Table 9: Application example of Safety Output Function .....	21
Table 10: Stop Category and Reaction of Fault Detection of SF15 and SF16 .....	22
Table 11: Stop Category and Reaction of Fault Detection of SF17 .....	23
Table 12: The $R_{offset}$ values of each product series .....	27
Table 13: Declaration of Incorporation.....	35
Table 14: Stopping Time and Distance for TM5-700 Series .....	42
Table 15: Stopping Time and Distance for TM5-900 Series .....	43
Table 16: Stopping Time and Distance for TM14 Series .....	44
Table 17: Stopping Time and Distance for TM12 Series .....	45

## Figures

Figure 1: The Definition of $R_{offset}$ .....	28
Figure 2: Extensible Singularity Point in Space .....	29
Figure 3: Wrist Singularity Point in Space .....	29
Figure 4: The Solution when Encountering Singularity Point in Space (1/2).....	30
Figure 5: The Solution when Encountering Singularity Point in Space (2/2).....	31

## Revision History Table

Revision	Date	Revised Content
1.00	2019-12-16	Original release
1.01	2020-03-05	Minor context revision

# 1. Comprehensive Information

## 1.1 Overview

This chapter describes the comprehensive important safety information of TM Robot. The user and system integrator of TM Robot must read and fully understand this chapter before using this robot.

## 1.2 Applicable Product Version

This document is only applicable to the combination of the following software and hardware versions of TM Robot. Users can check the hardware version and software version on “Techman Robot Product Brief Information” sheet in the control box carton, or through these methods: checking the hardware version on the product label on the control box and checking the software version from the software information button in the UI of TMflow. If the software version of the robot has been upgraded and is different from the original out-of-the-box one, users should only check the software version from the UI of TMflow.

Safety System version: TECHMAN ROBOT Safety System 3.2*	
Hardware version	HW 3.2
Software version	SW 1.76



\*Within the scope of hardware and software combination above, the safety system version remains the same as TECHMAN ROBOT Safety System 3.2

Table 1: Safety System Version

Users shall confirm whether the software and hardware version of the TM Robot is consistent with the applicable product version of this *Safety Manual*. The Corporation is not responsible for any safety issues caused by referring to the safety instruction of an incorrect version.

## 1.3 Safety Warning Symbols

The following table defines the levels of the safety warning symbols that are marked in each paragraph in this Manual. Read carefully and comply with each paragraph to avoid harm to people or equipment.

	<b>DANGER:</b> Identifies an imminently hazardous situation which, if not avoided, is likely to result in serious injury, and might result in death or severe property damage.
	<b>WARNING:</b> Identifies a potentially hazardous situation which, if not avoided, will result in minor or moderate injury, and might result in serious injury, death, or significant property damage.
	<b>CAUTION:</b> Identifies a potentially hazardous situation which, if not avoided, might result in minor injury, moderate injury, or property damage.

**WARNING: ELECTROCUTION RISK**

Identifies a hazardous electrical situation.

Table 2: Safety Warning Symbols

#### 1.4 Safety Precautions

**DANGER:**

This product can cause serious injury or death, or damage to itself and other equipment, if the following safety precautions are not observed.

- All personnel who install, operate, teach, program, or maintain the system must read the *Hardware Installation Manual*, *Software Manual*, and *Safety Manual* according to the software and hardware version of this product, and complete a training course for their responsibilities concerning the robot.



Read Manual and Impact Warning labels

- All personnel who design the robot system must read the *Hardware Installation Manual*, *Software Manual*, and *Safety Manual* according to the software and hardware version of this product, and must comply with all local and national safety regulations of the location where the robot is installed.
- Observe the “Intended Use” section in *Safety Manual*.
- If the installation and application does not observe human-robot collaboration regulations of the safety regulations, the user is responsible for providing safety barriers around the robot to prevent anyone from accidentally coming into contact with the robot when it is in motion.
- If any local or national electrical regulation requires, power to the robot and its power supply must be locked out and tagged out, or have means to control hazardous energy or implement energy isolation before any maintenance is performed.
-  Dispose of the product in accordance with the relevant rules and regulations of the country or area where the product is used.

## 1.5 Validation and Responsibility

The information provided in this Manual does not include how to design, install and operate a complete arm application, nor does it include the peripheral devices that will affect the overall system safety. The design and installation of the complete system must comply with the standards and regulations for safety requirements in the country located. The robot integrator needs to understand safety laws and safety regulations in the local countries, in order to avoid major risks existing in the entire system.

This includes but is not limited to:

- Performing a risk assessment of the whole system
- Adding other machines and additional risk reduction measures based on the results of the risk assessment
- Using appropriate software safety features
- Ensuring the user will not modify any safety measures
- Ensuring all systems are correctly designed and installed
- Specifying instructions for use
- Clearly marking the contact information of the integrator that installed the robot
- Making relevant documents accessible, including the risk assessment, and this manual



### **CAUTION:**

This product is partly completed machinery. The design and installation of the complete system must comply with the safety standards and regulations in the country of use. The user and integrators of the robot should understand the safety laws and regulations in their countries and prevent major hazards from occurring in the complete system.

## 1.6 Limitation of Liability

Even if the safety instructions are followed, any safety-related information in the manual shall not be considered as a guarantee that the product will not cause any personal injury or damage.

## 1.7 Overall Safety Warning

These safety warnings are relevant for the entire manual.





**DANGER:**

1. Before transporting, installing, operating, maintaining and repairing this product, make sure to read the product specification and operation manual in detail. Confirm that all the conditions comply with the requirements of the specification and the Manual, to avoid unintended accidents (for example: improper operation or conditions of use that exceed the product specification) that may result in injury to personnel.
2. Before installing and using this product, the integrator must perform a risk assessment and implement risk reduction measures.
3. Users shall create procedures for emergency and abnormal situations.
4. Before using this product, make sure that the emergency stop device functions correctly.



**WARNING:**

1. Before disassembling or repairing this product, make sure that the power has been turned off and disconnected before proceeding to avoid injury to people or damage to machinery caused by inadvertent short circuit or electric shock.
2. When operating this product, the operator shall avoid wearing loose clothing or wearing other accessories (such as: necklaces, ties, bracelets, etc.) to avoid injury caused by clothing or accessories becoming entangled in the machine during operation.
3. If the product malfunctions, follow the established procedures of your organization to obtain repair of the product. Do not attempt to repair the product yourself to avoid damage to the machinery.
4. Before the robot is in operation, make sure that each part has been completely mounted to avoid any possibility of accidents.
5. Before starting the operation of the robot, confirm that there are no persons or obstacles that may intrude into the operating area during operation. If the operating environment uses human-robot cooperative operation, be sure to complete the due risk assessment before starting the operation.
6. It is forbidden for any unauthorized person to operate this product in order to avoid any possibility of injury to personnel or damage to the machinery.
7. Do not install or operate this product in a hazardous area (for example: strong magnetic field, hazardous gas, fire source, or flammable product) In order to prevent the machinery from causing danger during operation because of external conditions.



**CAUTION:**

1. Before operating the robot, confirm the status of the machinery warning light.
2. After editing the task flow, operate the robot in the Manual Mode first, and confirm that all the movements in the task flow are correct before switching the operation mode to Auto Mode.
3. During the operation of machinery, do not turn off the power supply to prevent possible damage to the system.
4. For the robot noise levels and related environmental conditions, refer to the *Hardware Installation Manual* for the corresponding hardware version.

### 1.8 Intended Use

The TM Robot is designed so the hazards can be reduced to tolerable levels when installed as specified and operated under normal and intended use. TM Robots have been designed and constructed in accordance with relevant safety standards. TM Robots are intended for use in parts assembly and material handling for payloads (including end-effector and workpiece) up to the “Maximum Payload” specification of each model.

The TM Robot focuses on the safety of human-robot cooperative operation by design, but the cooperative operation is only for application procedures that have undergone a risk assessment including robots, related peripheral equipment and working environment.

Any use or application should consider the risk assessment. If the use is different from the intended application, The Corporation will not bear any responsibility. The Corporation clearly specifies that the following uses are not suitable for the TM Robot. This is not a complete list.

- Use in a potentially hazardous environment
- Use in any applications that may threaten human lives
- Use in any application that may cause personal injuries
- Use before completion of the risk assessment and implementation of risk reduction measures
- Use for life support
- Use when the rated performance cannot be reached
- Use when the reaction time of safety functions is insufficient
- Use without appropriate parameters in operations
- Use in applications which may cause damage to the robot itself
- Restricted movement of persons
- Use without proper mounting of the robot
- Use involving excessive oscillations when moving
- Use without proper design of earthquake-prevention mounting when installed in earthquake zones

- Use without safe access to (or at/from) the work station
- Use in the presence of exhaust gases/lack of oxygen at the work position
- Use in the presence of flame (flammability of the cabinet, lack of extinguishing means)
- Use with mechanical hazards at the work position: a) rollover; b) fall of objects, penetration by objects; c) break-up of parts moving at high speed; d) contact of persons with machine parts or tools (non-collaborative machines)
- Use with insufficient visibility from the work positions
- Use with inadequate lighting
- Use with inadequate seating
- Use with insufficient means for escape or entrapment avoidance
- Use with inadequate location of manual controls
- Use with inadequate design of manual controls and their mode of operation

## 1.9 Risk Assessment

Before installing and using this product, the user must first perform a risk assessments based on the conditions of use. Risk assessments can be in reference to the specifications of ISO 10218-2, ISO 12100 and ISO/TS 15066 documentations. The purpose of a risk assessment is to anticipate any accidents that may occur during the operation process and by means of appropriate protective measures to reduce the occurrence of accidents or to reduce the severity of injury to persons in the event of an accident. Therefore, the risk assessment needs to include any operational actions of the machinery within the scope of the assessment. After the risk assessment is completed, the user can use external related components (i.e. sensing components, emergency stop devices, fences or railings, etc.) as well as the parameter settings of safety functions in the operating system, to reduce possible occurrence of accidents. Additional safety-related components must be installed in accordance with the manufacturer's specifications for the required risk reduction. For operating system safety settings and other safety components usage, read and understand this manual, the *Software Manual* and the *Hardware Installation Manual* of corresponding versions.

Potential hazards requiring additional risk reduction measures may include but are not limited to:

1. Finger(s) (especially in the case of hand guiding) caught between the rear end of the camera module and the joint module(s).
2. The palm or finger injured by the motion of the robot or the hand guide teaching, if caught between the robot end-effector (including the workpiece) and the robot body.
3. Being hit by a robot and injured.
4. Entrapment between a robot and a fixed surface.
5. Incorrect human-robot collaborative workspace setup, parameter settings or project operation.
6. TCP force may be estimated incorrectly when robot is passing the area near singularity point in space, due to

the nature of singularity.



**WARNING:**

Ensure compliance with all local and national safety and electrical codes for the installation and operation of the robot system.



**WARNING:**

Provide appropriately sized Branch Circuit Protection and Lockout/Tagout Capability in accordance with the National Electrical Code and any local codes.



**WARNING: ELECTROCUTION RISK**

It is necessary for a skilled and instructed person to perform AC power installation. During installation, it is mandatory to prevent unauthorized third parties from turning on power with the use of lockout/tagout measures.

Failure to use appropriate power can lead to malfunction or failures of the robot or hazardous situations.

## 2. Safety Function

### 2.1 Overview

TM Robot incorporates multiple safety functions, and provides interfaces for additional external protective devices.

### 2.2 General Information

The following describes common information of the TM Robot system safety functions:

#### 2.2.1 Safety Function Definitions

Safety Function Definitions of TM Robot System are listed in the following table:

Safety Function Number	Name	Robot Stopping Function	Structure Category	PL
SF0	Robot Stick ESTOP	Emergency Stop	Cat. 3	d
SF1	User Connected ESTOP Input	Emergency Stop	Cat. 3	d
SF2	Encoder Standstill	Protective Stop	Cat. 2	d
SF3	User Connected External Safeguard Input	Protective Stop	Cat. 2	d
SF4	Joint Torque Monitoring	Protective Stop	Cat. 2	d
SF5	Joint Position Limit	Protective Stop	Cat. 2	d
SF6	Joint Speed Limit	Protective Stop	Cat. 2	d
SF7	TCP Speed Limit	Protective Stop	Cat. 2	d
SF8	TCP Force Limit	Protective Stop	Cat. 2	d
SF9	User Connected External Safeguard Input for Human-Machine Safety Settings	--	Cat. 2	d
SF10	Robot ESTOP Output	--	Cat. 3	d
SF11	User Connected External Safeguard Output	--	Cat. 3	d
SF12	User Connected External Safeguard Output for Human-Machine Safety Settings	--	Cat. 3	d
SF13	Robot Internal Protective Stop Output	--	Cat. 3	d
SF14	Robot Encoder Standstill Output	--	Cat. 3	d
SF15	User Connected Enabling Device Input	Protective Stop	Cat. 2	d
SF16	User Connected ESTOP Input without Robot ESTOP Output	Emergency Stop	Cat. 3	d
SF17	Cartesian Limit	Protective Stop	Cat. 2	d

Table 3: Safety Function Definitions

Note:

1. The structure category according to ISO 13849-1:2015.
2. PL (Performance Level) in accordance with ISO 13849-1:2015.
3. Emergency stop and protective stop in accordance with ISO 10218-1:2011.
4. Stop categories in accordance with IEC 60204-1.

### 2.2.2 Stopping Time and Stopping Distance in the Safety System

Safe stopping time is the time required from when an emergency stop or protective device (i.e. internal or external) is activated and motion stops. In this system, activating the emergency stop button will apply Cat. 1 safety stop. Activation of a safety function or external safety protective device will be a Cat. 2 stop. It may be necessary for the user or the system integrator to take these stop times into consideration when implementing risk reduction measures. The robot continues moving during this time, which can transmit energy and present additional risk. Refer to Appendix C for stopping time and stopping distance.

### 2.2.3 Software Safety Setting Permissions

A change management process should be in place listing known acceptable settings and potential hazards. Changes are made in the permissions management function. The authorized user must log in with administrator's privilege to set all levels of permissions appropriately. Cybersecurity measure should take place when using a network connection. The Corporation is not liable for the possible harm caused by malicious attacks or intrusion of the users' network to modify the permissions management system or safety setup.

## 2.3 Explanation of Safety Functions

### 2.3.1 SF0 Robot Stick ESTOP and SF1 User Connected ESTOP Input

The SF0 Robot Stick ESTOP refers to the built-in Emergency Switch on the Robot Stick of the TM Robot control box, and the SF1 User Connected ESTOP Input refers to the Emergency Stop Port on the control box, which is applicable to connect additional emergency switches.

Refer to the table below for the stop category and the reaction of the fault detection of the safety functions. The functions come with discrepancy detection to maintain safety when detecting conflicting signals from the dual channel input. When a discrepancy occurs, the system will enter and lock in a safety status. To resume from the safety status, first check the input wiring, correct it, and let the dual inputs open and close again, to enable the robot to the resume status of the safety function. When any fault other than discrepancy in the safety functions is detected, the system performs a Cat. 0 stop. When Cat. 0 stop occurs, reboot the robot system to recover from Cat.0 stop status.

Safety Function Number	Name	Stop Category	Action of Fault Detection
SF0	Robot Stick ESTOP	Cat. 1 stop	Discrepancy: Cat.1 Stop Others: Cat. 0 stop
SF1	User Connected ESTOP Input	Cat. 1 stop	Discrepancy: Cat.1 Stop Others: Cat. 0 stop

Note: Stop categories in accordance with IEC 60204-1.

Table 4: Stop Category and Action of Fault Detection of SF0 and SF1

The user can stop movement by pressing the Emergency Stop button. After the movement of the robot has ceased, the user must confirm that no hazardous conditions are present before manually releasing the Emergency Stop button to allow reactivation of the robot. The Emergency Stop should be used only when a critical condition occurs. To stop the movement of the robot under normal operation, use the Stop Button on the Robot Stick.

If the risk assessment requires additional Emergency Stop devices, the selected device must comply with the requirements of the IEC 60204-1. Any additional Emergency Stop Devices must be connected to the User Connected ESTOP Input port (SF1), so they do not diminish the overall performance level of the Emergency Stop.

Activation of an emergency stop initiates a Cat. 1 stop. The Indication Light Ring of the robot will not display light and the three lights on the Robot Stick will be constantly blinking. The steps to reset the emergency stop are as follows:

1. Rotate the Emergency Switch to the pop-up state. At this time, the robot arm will be re-powered. The Indication Light Ring will have the light blue light on to indicate the Safe Start up Mode.
2. Press the Stop Button on the Robot Stick for about three seconds. The robot will perform the calibration action of the start-up process and return to the previous operating mode.



**WARNING:**

The power of the robot arm will be cut and the joint brake will be activated, if the Emergency Stop is triggered. The Indication Light Ring of robot's end module will not show light and the three lights from the robot stick will be constantly blinking. In this case, although each of the joints will be automatically locked by their brakes, the robot body will still drop slightly, before it completely stops. Pay attention to the risk that the end part of the robot may pinch the operator or collide with other objects.

**WARNING:**

During an Emergency Stop, power to the end effector will be cut. If the system was integrated with a power I/O enabled end effector, the emergency stop condition may cause the workpiece to be dropped.

**CAUTION:**

Personnel should be outside of the robot's operational space (areas that robot can reach) when recovering from the emergency stop.

Clear off the loading at the tool end before recovering from the emergency stop.

**CAUTION:**

During the Joint Position Calibration period, each joint of the robot will perform a calibration motion. Make sure the robot pose is in a clear space of at least 5 degrees per joint to perform the calibration motion before starting the calibration. At the same time, make sure the TCP, which may have a long distance to the robot flange, will not causing harm during the calibration motion.

### 2.3.2 SF2 Encoder Standstill

This safety function is automatically activated after every Cat. 2 Stop. Encoders of each joint are monitored continuously to check if there is any unintended motion until the user acknowledges and manually resets the robot from the state of Cat. 2 Stop. If there is any unintended motion, this safety function will trigger a Cat. 0 Stop. When any fault other than discrepancy is detected in the safety function, the system performs a Cat. 0 stop. When a Cat. 0 stop occurs, reboot the robot system to recover from Cat. 0 stop status.

### 2.3.3 SF3 User Connected External Safeguard Input and SF9 User Connected External Safeguard Input for Human-Machine Safety Settings

These two safety inputs are present on the Safeguard Port of the robot control box. For the related connection and usage, refer to the *Hardware Installation Manual*. Resuming from the SF3 User Connected External Safeguard Input protective stop and SF9 User Connected External Safeguard Input for Human-Machine Safety Settings can be manual or auto. If manual resume is configured, press the PLAY button to resume the original status. For the setting for manual or automatic resume, refer to the relevant contents in the *Software Manual*.

Refer to the table below for the stop category and the reaction of fault detection of the safety functions. The functions come with discrepancy detection to maintain the safety status when detecting conflicting signals from a dual channel input. When a discrepancy occurs, the system will enter and lock in a safety status of Cat. 1 stop. To resume from the safety status, first check the input wiring, correct it, and follow the steps below to resume.



1. Let the dual inputs open and close again. At this time, the robot arm will be re-powered. The Indication Light Ring will have the light blue light on to indicate the Safe Start up mode.
2. Press the Stop Button on the stick for about three seconds. The robot will perform the calibration action of the start-up process and return to the previous operating mode.

When any fault other than discrepancy detected in the safety functions, the system performs a Cat. 0 stop. When Cat. 0 stop occurs, reboot the robot system to recover from Cat.0 stop status.

Safety Function Number	Name	Stop Category	Reaction of Fault Detection
SF3	User Connected External Safeguard Input	Cat. 2 stop	Discrepancy: Cat. 1 Stop Others: Cat. 0 stop
SF9	User Connected External Safeguard Input for Human-Machine Safety Settings	--	Discrepancy: Cat. 1 Stop Others: Cat. 0 stop

Note: Stop categories in accordance with IEC 60204-1.

Table 5: Stop Category and Action of Fault Detection of SF3 and SF9

SF9 is a function to decrease the robot speed to which is set in Human-Machine Safety Settings and comes with a deceleration time parameter that users can configure to prevent force/torque related safety functions from triggering by the dramatic slowdown from high speed. The upper limit of the deceleration time is 800 milliseconds. Note that there is a fixed time delay of 1122 milliseconds after the trigger of Human-Machine Safety Settings to start to monitor the TCP speed to let the robot decrease to speed from Human-Machine Safety Settings. Users should take these timings into considerations for the risk assessment of applications and set the distance of the safeguard properly.

#### 2.3.4 SF4~SF8 Defined Safety Functions

The name and description of SF4 to SF8 safety functions are listed in the following table:

Safety Function	Name	Description
SF4	Joint Torque Monitoring	The additional torque that joint received after compensating the weight of tool in TCP setting, weight of workpiece in payload setting in programming, and the weight of the robot body. Each joint's torque limit condition can be set. When the robot exceeds a set value, it will trigger a protective stop.
SF5	Joint Position Limit	Each joint's motion angle limit can be set. When the robot exceeds a set value, it will trigger a protective stop.
SF6	Joint Speed Limit	Each joint's motion speed range can be set. When the robot exceeds a set value, it will trigger a protective stop.
SF7	TCP Speed Limit	The speed limit of the tool center point can be set. When the robot exceeds a set value, it will trigger a protective stop.
SF8	TCP Force Limit	The additional force that TCP received after compensating the weight of tool in TCP setting and weight of workpiece in payload setting in the programming. The force limit of the tool center point can be set. When the robot exceeds a set value, it will trigger a protective stop. The force of the tool center point is the external force at the tool center point estimated through the model by the robot system. It is not the protection value of applied external force at the tool center point by the robot system.

Table 6: SF4~SF8 Defined Safety Functions

Refer to the table below for the stop category and the action of fault detection for the safety functions. When any fault other than discrepancy is detected in the safety functions, the system performs a Cat. 0 stop. When Cat. 0 stop occurs, reboot the robot system to recover from Cat. 0 stop status.

Safety Function Number	Name	Stop Category	Reaction of Fault Detection
SF4	Joint Torque Monitoring	Cat. 2 stop	Cat. 0 stop
SF5	Joint Position Limit	Cat. 2 stop	Cat. 0 stop
SF6	Joint Speed Limit	Cat. 2 stop	Cat. 0 stop
SF7	TCP Speed Limit	Cat. 2 stop	Cat. 0 stop
SF8	TCP Force Limit	Cat. 2 stop	Cat. 0 stop

Note: Stop categories in accordance with IEC 60204-1.

Table 7: Stop Category and Reaction of Fault Detection of SF4~SF8

Refer to the relevant contents in the *Software Manual* for the setting of each item. Users can use any method listed below to recover the robot from protective stop manually from SF4 to SF8:

- Pressing the STOP button on robot stick
- Any operation on the icons in the left sidebar of the TMflow (except Shutdown)
- Pressing the FREE button in the end module of TM Robot

- Switching the mode on the robot stick



**DANGER:**

Pay attention that the "TCP Force" (Tool Center Point Force) is the external force at the tool center point estimated through the model by the robot system, not the protection value of the external force at the tool center point on the robot system. When the robot system exceeds the external force value at the tool center point, the robot will perform a category 2 stop. In this condition, applied forces will exceed this value. Therefore, clearly understand the amount of the external force applied before the robot comes to a complete stop. The extent this value will be exceeded will increase as the robot speed increases. This cannot be the primary risk mitigation for human-robot collision.



**DANGER:**

When the motion of TM Robot is passing the area near singular space, due to the nature of singularity, the TCP force may be estimated incorrectly. Users can set the robot's motion properly, e.g. do not set the motion too close to the singularity point in space, to avoid this situation. This is a residual risk and users should apply risk assessment for the detection of SF8 TCP force near the singularity case. SF8 TCP force should not be solely applied as the only safety protection measure in human-robot collision case. It's always recommended to include SF4 Joint Torque Monitoring in the human-robot collision safety protection measure.

### 2.3.5 SF10~SF14 Safety Output Functions

SF10~SF14 provides the safety output functions connecting to other devices for system integration. Refer to the table below for the stop category, the definition of the triggered status, the action of the output signal, and the action of the fault detection. When any fault other than discrepancy is detected in the safety functions, the system performs a Cat. 0 stop. When Cat. 0 stop occurs, reboot the robot system to recover from Cat. 0 stop status. For the related connections and usages, refer to the *Hardware Installation Manual* of the respective hardware version. The definition of triggered status is when the connected device should stop or enter the safety status. These safety outputs will be LOW when triggered.

For SF10 Robot ESTOP Output, note that it only reflects the emergence stop resulting from SF0 and SF1. The emergency stop resulting from SF16 User Connected ESTOP Input without Robot Output will not reflect on SF10.

Safety Function Number	Name	Output Signal in Regular Status	Definition of Triggered Status	Output signal of Triggered Status	Action of Output when Discrepancy Detected from Safety IO Input Ports	Action of Output when System Cat. 0 Stop Occurs	Action of Output when System Cat. 1 Stop Occurs	Action of Fault Detection
SF10	Robot ESTOP Output	HIGH	ESTOP result from SF0 and SF1	LOW	LOW	LOW	LOW	Cat. 0 stop
SF11	User Connected External Safeguard Output	HIGH	Protective Stop result from SF3	LOW	LOW	LOW	HIGH	Cat. 0 stop
SF12	User Connected External Safeguard Output for Human-Machine Safety Settings	HIGH	External Safeguard Input result from SF9	LOW	LOW	LOW	HIGH	Cat. 0 stop
SF13	Robot Internal Protective Stop Output	HIGH	Protective Stop result from SF4,5,6,7,8,15,17	LOW	For SF 15 LOW  For Others --	LOW	HIGH	Cat. 0 stop
SF14	Robot Encoder Standstill Output	HIGH	Standstill is not monitoring (Robot is moving)	LOW	--	LOW	LOW	Cat. 0 stop

Table 8: Output Signal and Action of Fault Detection of SF10~SF14

Refer to the table below for indication of the example of application using the safety functions.

Safety Function Number	Name	Example of Application
SF10	Robot ESTOP Output	Stop other devices when emergency stop button connected to the robot triggered.
SF11	User Connected External Safeguard Output	Stop other devices when safeguard connected to SF3 of the robot triggered.
SF12	User Connected External Safeguard Output for Human–Machine Safety Settings	Stop other devices or let it change to Human–Machine Safety Settings when safeguard connected to SF9 of the robot triggered.
SF13	Robot Internal Protective Stop Output	Stop other devices when robot is stopped for SF4,5,6,7,or 8. Stop other devices when the robot is stopped for SF15 Enabling Device. Stop other devices when the robot is stopped for SF17 Cartesian Limit.
SF14	Robot Encoder Standstill Output	Prevent other devices from moving when the robot moves, e.g. application for robot mounted on an AGV or motional axis. (One should stand still while the other one is moving)

Table 9: Application example of Safety Output Function



**WARNING:**

SF14 Robot Encoder Standstill is designed for stopping the other machine when the robot is moving. When the robot is monitored by the encoder standstill, the output is HIGH, and this signal should not be used to stop the other machine when the robot is standstill. Once the wiring is cut, the machine is allowed to move in this kind of integration scenario. To stop the other machine while the robot is standstill, use other measures such as the safeguard output of the robot or use the safety device to stop both the robot and other machine at the same time.

2.3.6 SF15 and SF16 Safety Input Functions

SF15 and SF16 provides more safety input functions for system integration.

SF15 User Connected Enabling Device Input provides the dual channel input ports for user to connect to a three-position enabling device when risk assessment indicates. Enable this safety function in the Safety Setting in the software to use it by referring to the *Software Manual* of the respective software version.

Note that the Open or Close status of this safety input will not affect the operation in Auto Mode. When this function is enabled and connected to the enabling switch, in Manual Mode, all manual control operations are enabled only when users press the three position enabling device in the middle position. If the Enabling Device is released or fully pressed, the robot performs a protective stop. When starting a manual trial run of the project pressing the PLAY button, the Enabling Device should be pressed in the middle position. When Enabling Device is released or fully pressed during the Manual Trial Run mode, the Project

Speed will always automatically return to 5%. Connect this safety function only to the three-position enabling device compliant with IEC60204-1. Note that the input of this safety function has two input statuses only, so the Enabling Device should not have an enabled output during the procedure from the fully pressed status to the fully released status.

SF16 User Connected ESTOP Input without Robot ESTOP Output provides an emergency input function without triggering SF10 Robot ESTOP Output. This safety function provides the possibility to prevent the deadlock of the emergency stop between the robot and other devices/machines in different system integration design.

Refer to the table below for the stop category and the reaction of fault detection of the safety functions. The functions come with discrepancy detection to maintain the safety status when detecting conflicting signals from a dual channel input. When discrepancy occurs, the system will enter lock in a safety status of Cat.1 stop. To resume from the safety status, first check the input wiring, correct it, and follow the steps below to resume.

1. Let the dual inputs open and close again. At this time, the robot arm will be re-powered. The Indication Light Ring will have the light blue light on to indicate the Safe Start up Mode.
2. Press the Stop Button on the Robot Stick for about three seconds. The robot will perform the calibration action of the start-up process and return to the previous operating mode.

When any fault other than discrepancy is detected in the safety functions, the system performs a Cat. 0 stop. When Cat. 0 stop occurs, reboot the robot system to recover from Cat. 0 stop status.

Safety Function Number	Name	Stop Category	Reaction of Fault Detection
SF15	User Connected Enabling Device Input	Cat. 2 stop	Discrepancy: Cat.1 Stop Others: Cat. 0 stop
SF16	User Connected ESTOP Input without Robot ESTOP Output	Cat. 1 stop	Discrepancy: Cat.1 Stop Others: Cat. 0 stop

Note: Stop categories in accordance with IEC 60204-1.

Table 10: Stop Category and Reaction of Fault Detection of SF15 and SF16



**DANGER:**

Enabling Devices only stop the robot in Manual Mode and will not stop the robot in Auto Mode.

### 2.3.7 SF17 Cartesian Limit

SF17 provides a safety function for users to set Cartesian limit on the robot. Cubical and cylindrical limits can be set, and both TCP and elbow are monitored. Refer to the table below for the stop category and the reaction of fault detection and the *Software Manual* of the respective software version for the parameters and procedure of setting.

To resume from the protective stop, following the steps below:

1. Switch to the Manual Control Mode.
2. Press the FREE button on the end module of the robot to hand guide the robot to leave the limited space.

Safety Function Number	Name	Stop Category	Reaction of Fault Detection
SF17	Cartesian Limit	Cat. 2 stop	Others: Cat. 0 stop

Note: Stop categories in accordance with IEC 60204-1.

Table 11: Stop Category and Reaction of Fault Detection of SF17



**DANGER:**

SF17 Cartesian Limit cannot be used as the only safety measure for preventing collisions between human and the robot. When this safety function is used, other means should be provided to prevent human or the limb enters the limited space or detect the entering of the limited space with a protective measure.



**WARNING:**

SF17 Cartesian Limit is designed for the robot to monitor once the robot's movement goes beyond the set limit and the robot performs a protective stop. It does not mean the spot to monitor will not exceed the limit due to the stopping time and the stopping distance. Take the stopping time and the stopping distance into consideration when using this safety function for setting the restricted space and the safeguarded space in system integration.

## 3. Safety Related Operation

These are the operating instructions for Safety-related robot functions and designs.

### 3.1 Joint Movement without Drive Power

The conditions of robot without driving force are emergency stop, start up from the packing pose, and loss of power. The first two can enter Safe Start up Mode when the emergency switch resets, and the latter is the situation when the robot loses external power entirely. The following describes how to operate it:

#### 3.1.1 During an Emergency Stop Procedure

The brake of each joint axis will automatically lock the joint, to avoid unlimited sagging of the robot's joints due to gravity. If you need to move the robot to resolve the condition, follow the steps listed below:

1. Releasing the Emergency Switch energizes the power to the robot.
2. Wait 10 seconds to enter the Safe Start Up Mode. The Indication Light Ring will turn light blue.
3. Press the FREE button continuously to release the joint axis brake and move the robot.
4. After the situation is resolved, press the stop button on the Robot Stick for about three seconds, the robot will perform the calibration startup process and return to the original operating mode.



**CAUTION:**

All personnel should be outside of the robot's operational space (areas that robot can reach) when recovering from the emergency stop.

#### 3.1.2 Extending the Robot from the Packing Pose

Refer to the *Software Manual* for the operation of extending the robot from the Packing Pose. The emergency stop reset method is in Section 2.3.1.



**DANGER:**

When using the FREE button to release brakes without motor power, the robot may sag due to gravity. Be prepared to support the robot system. If it not possible to support the robot system, release the FREE button immediately, which will lock the robot joint brakes.

#### 3.1.3 Power Loss

If power loss to an end-effector can result in a hazardous condition (e.g. dropping of a workpiece), possible methods to reduce the risk may include but are not limited to:

- Use the 24V electrical output provided by the control box to supply the power to end effector instead of using the End Module of robot to supply power.
- Install an independent power supply for the end effector.
- If the end effector is a pneumatic control, use a low potential actuation design.



- Select the end effector with self-maintaining function / mechanical design.

If it is necessary to manually move the arm joint:

1. Remove the joint module protective cover screw and the joint module protective cover
2. Press the brake solenoid valve to release the brake

Refer to the brake release illustration in the *Hardware Installation Manual*.

## 3.2 Operation Mode and Mode Switching

TM Robot has two operation modes: Manual Mode (reduced speed and high speed) and Auto Mode. The modes are visually distinguishable by the color of the mode indicator on the Robot Stick and the Indication Light Ring on the robot's end module. The robot is in Auto Mode when starting up.

### 3.2.1 Auto Mode

In Auto Mode the Indication Light Ring on the end module displays blue light and the Mode Indicator on the Robot Stick is in Auto position. The user can press the Robot Stick Play/Pause button to play/pause the robot program. The robot speed plays according to the project speed. In Auto Mode, the FREE button on the end module does not actuate, and cannot perform Hand Guiding operation.

### 3.2.2 Manual Mode

In Manual Mode the Indication Light Ring on the end module displays in green and the Mode Indicator on Robot Stick is in Manual position. In Manual Mode, it can be divided into Manual Control Mode (Manual Reduced Speed), Manual Trial Run Mode (Manual High Speed), and Hand Guide Mode. When the protective stop occurs, the manual control operation in Manual Control Mode and Hand Guide Mode are prohibited by the system.



**WARNING:**

Wherever possible, the manual mode of operation shall be performed by all persons outside the safeguarded space.

#### 3.2.2.1 Manual Control Mode (Manual Reduced Speed)

In Manual Control Mode, the user can jog the robot with controller UI in TMflow or the Robot Stick. If the robot speed exceeds 250 mm/sec, it will enter an error stop state.

#### 3.2.2.2 Hand Guide Mode

Hand Guide Mode can be activated in Manual Control Mode only. Press and hold the FREE button on the End Module to enter Hand Guide Mode, and release the FREE button to return to Manual Control Mode.

### 3.2.2.3 Manual Trial Run Mode (Manual High Speed)

In Manual Trial Run Mode, users can test the robot program by navigating to the TMflow project editing page and pressing the Play/Pause button on the Robot Stick. The initial project speed will reduce to 5% during each trial run, forcing the path motion of the robot lower than 250 mm/s. The +/- buttons on the Robot Stick are for the adjustment of the project run speed. Each button press increases or decreases project run speed by 5%.



**WARNING:**

The person should be outside of the safeguarded space when using Manual Trial Run Mode.

### 3.2.3 Switch Between Modes

For how to switch between modes, refer to the latest *Software Manual* of the respective software version of the robot system.



**DANGER:**

Prior to selecting automatic operation, any suspended safeguards shall be set back to full functionality.

## 3.3 Hold to Run

When the TM Robot is in Manual Control Mode, the functions include:

- joint angle movement
- robot base end movement
- tool base end movement
- self-defined base end movement
- move to visual initial position
- visual servo action
- step run
- move to point
- hand guiding
- others

Hold to Run has two categories:

- Jog the robot by continuously pressing the + / - Button of the Robot Stick.
- Jog the robot by continuously pressing the + / - Button in TMflow software.

Once the + / - Button is released, the robot will stop operation immediately and will continue operation when pressed again. If TMflow connects to the robot through Ethernet or Wi-Fi, the robot will automatically issue a

protective stop when releasing the + / - Button or the connection is broken. Depending on the quality of connection, there may be a maximum detection delay of 800ms for loss of communication. Using the physical button to perform Hold to Run function, the detection time of releasing the button is up to 30ms.

### 3.4 Singularity Point

The motion of an articulated robot is often limited by the kinematic design, and cannot perform Cartesian motion control under all joint positions. The joint position that will cause the robot to be unable to perform Cartesian control is a singularity point. When the robot encounters a singularity point, it will stop motion and initiate a warning.

Three types of singularity point for TM Robot:

- Internal Singularity Point in Space
- Extensible Singularity Point in Space.
- Wrist Singularity Point in Space.

#### **Internal Singularity Point in Space:**

The distance from the intersection of the rotational axes of the fifth joint and the sixth joint to the extended line of the rotational axis of the first joint is defined as  $R_{offset}$ . The cylindrical space that is formed by  $R_{offset}$  as the radius and centered on the extended line of the rotational axis of the first joint is the Internal Singularity Point in Space. As soon as the robotic arm approaches the Internal Singularity Point in Space, the arm will stop and issue a warning. The  $R_{offset}$  values of each product series are shown in the following table:

Main model	$R_{offset}$
TM5 Series	122.3 mm
TM12/14 Series	156.3 mm

Table 12: The  $R_{offset}$  values of each product series



Figure 1: The Definition of  $R_{offset}$ .

**Extensible Singularity Point in Space:**

When the third joint is almost at its zero degree, which means the robot is almost at the maximum working radius. The space exceeding this radius is the Extensible Singularity Point in Space. In this space, the robot will stop and report a warning due to exceeding the motion range of the robot.

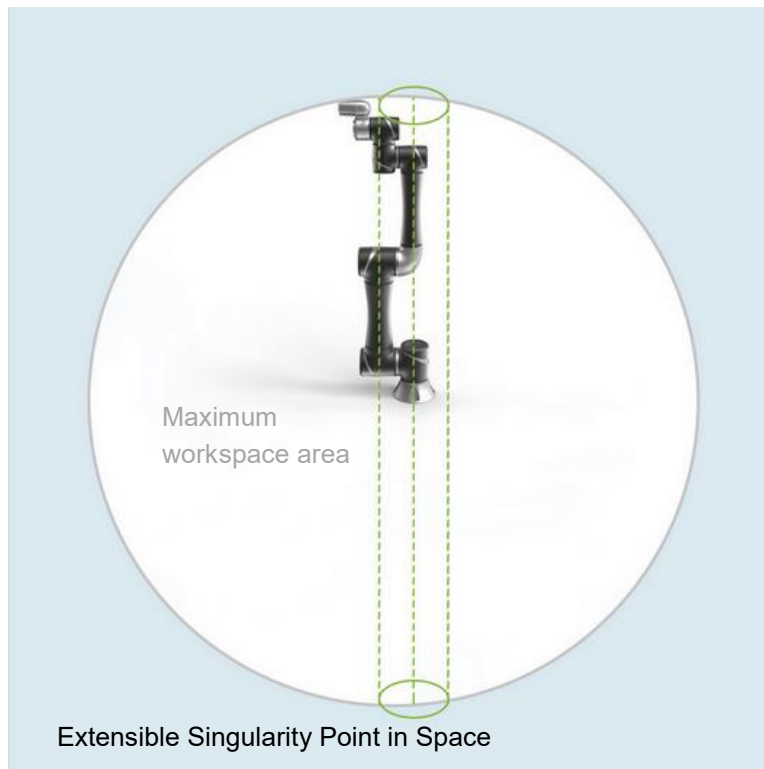

The maximum working range can be achieved when the third joint is almost at zero degrees

Figure 2: Extensible Singularity Point in Space

**Wrist Singularity Point in Space:**

When the rotational axes of the fourth and the sixth joints are parallel, the robot will enter the Wrist Singularity Point in Space. At this time, the motion of the arm will cause a large-angle displacement of the fourth joint, but it will be stopped due to stop criteria of motion speed. Once the robot enters the Wrist Singularity Point in Space, it will stop and report an error.

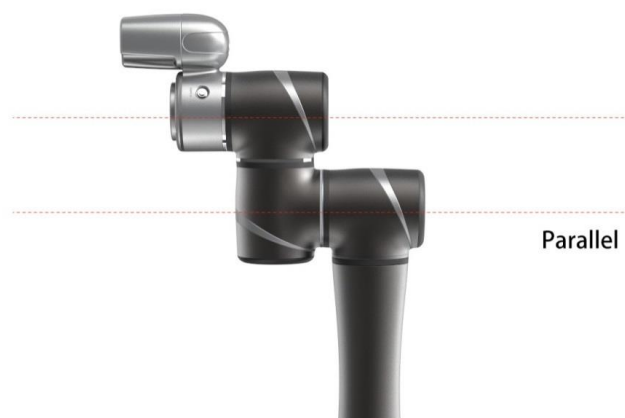

When the fourth and sixth joint are nearly parallel, the robot is about to enter the Wrist Singularity Point in Space.

Figure 3: Wrist Singularity Point in Space

### The Solution when Encountering Singularity Point in Space:

When the robot reports singularity, confirm the posture of the robot. If the tool end path crosses the internal cylinder as shown in the figure below, check the first point description. If the rotational axes of the fourth and sixth joints of the robot are parallel, check the second point description below.

1. When the arm reports a warning due to the Internal Singularity Point in Space, press the FREE button to release it from the posture. Change the point position or change the motion type to PTP between the points to avoid the arm path between the points crossing the Internal Singularity Point in Space, as shown in the figure below.

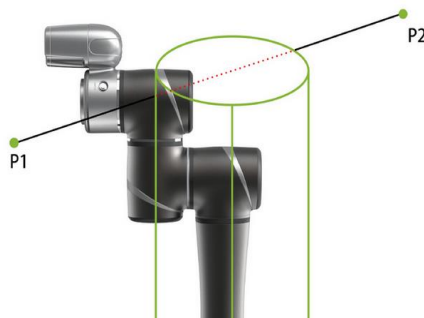

Figure 4: The Solution when Encountering Singularity Point in Space (1/2)

When the path crosses the Internal Singularity Point in Space, singularity will be triggered. Adjust the path and confirm that it will not cross the Internal Singularity Point in Space.

2. When the robot reports a warning because of entering the Wrist Singularity Point in Space, press the FREE button to release it. When the rotational axes of the fourth and the sixth joint are in parallel, if users still try to perform Cartesian motion, the Wrist Singularity Point in Space will be encountered. At this time, the method in the following figure can be used to avoid the rotational axes of the fourth and the sixth joints being parallel.

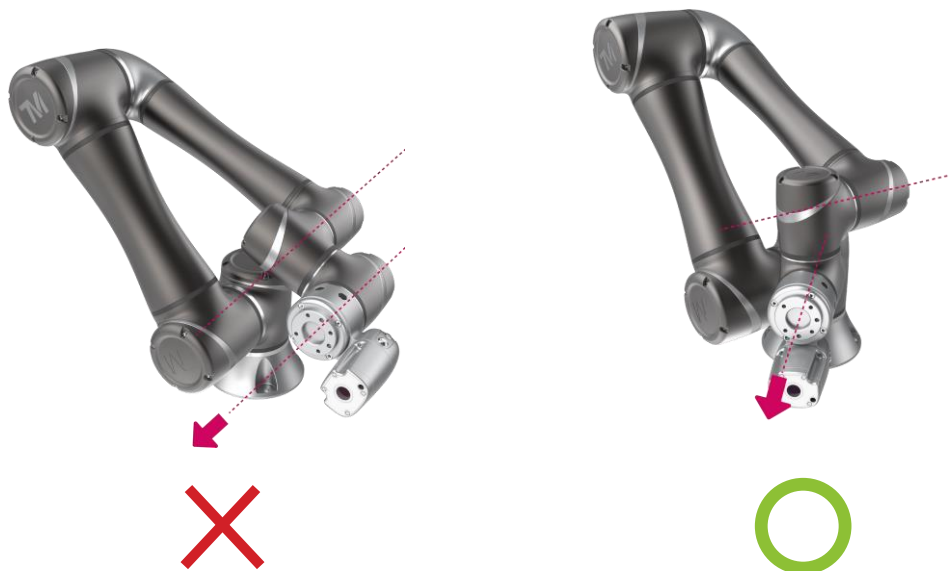

Figure 5: The Solution when Encountering Singularity Point in Space (2/2)

This example demonstrates how to avoid the rotational axes of the fourth and sixth joint being parallel, when the user needs to move the robot according to tool Z-axis.

### 3.5 Replacing the Robot Stick in Local Control

When users use other means to replace the local control function of the Robot Stick, the Robot Stick should not be accessed and used in local control at the same time. For example,

- Do not use devices like teach pendants when using the Robot Stick at the same time in local control.
- Do not enable and use the teach pendant function\* on a keyboard when using the Robot Stick at the same time in local control.

\*Supported by the software version newer than SW1.72 with the Keyboard Hot Key functions.

## 4. Compliance of Safety Regulations

This section describes the compliance and certification of this product to international safety regulations.

This product complies with to the following international safety regulations:

**ISO 10218-1:2011**

**ISO/TS 15066**

**ISO 13849-1:2015**

Certification: Third-party certification (refer to the certificate in Appendix A)

### 4.1 Compliance

This product complies with the combined scope of ISO 10218-1:2011 and ISO/TS-15066.

The relevant design and corresponding provisions in safety regulations of this part are listed in the following sections.

#### 4.1.1 Requirement of Enabling Device

The power and force limiting functions provide the alternative measures for the requirement of an enabling device per ISO/TS 15066:2016.

Means are provided for connection of an Enabling device when required by the risk assessment.

#### 4.1.2 Access of Safety Setting

TM Robot's safety setting has been integrated with the user's permission system of the entire product.



## 5. Declaration of Incorporation

The following is based on the Declaration of Incorporation in application of 2006/42/EG, Annex II, No. 1 B

The robot product of the Corporation is a partly completed machinery. When it is put into automation applications, it needs to be integrated with other equipment, and appropriately installed with the safety related measures and design before it can be used. When the semi-finished products are to put on the market, the following requirements according to 2006/42/EC Annex I need to be achieved. It must be noted that since the TM Robot product is easy to use, the “system integrator” here refers to the end user who uses the product directly through simple installation.

A: Not related

B: Satisfied by machinery equipment provider

C: Responsibility of the system integrator

Attention: in the following tables:

- Items marked as A: The scope of use of this product has been exceeded, and is not included into the consideration, or it is not directly related to this product.
  
- Items marked as B solely: The items that are to be satisfied by the machinery equipment provider, meaning the machinery provider has satisfied or has specified in each of the Software and Hardware / Safety Manual. In the latter case, the system integrator is still responsible for the full compliance with specification of machinery equipment provider. In addition, in the entire system, the satisfaction of machinery equipment belonging to the system but not belonging to this product is not included here, and the system integrator must be responsible for it.
  
- Items marked as C solely: The item cannot be satisfied by this product. The system integrator must implement additional measures.
  
- Items marked as both B and C:
  1. When the item can be satisfied in using this product itself, the machinery equipment provider of this product shall satisfy it.
  2. When the system integrator replaces the related functions of this product through system integration, the system integrator shall satisfy it. For example:
    - Replacing the emergency switch of the Robot Stick with an external emergency switch connected to the Emergency Switch Port

- Replacing the Play/Stop Button of the Robot Stick with user-defined IO or the functions of equivalent functions.

When this type of design replaces the original function of this product, the system integrator shall be responsible for the equivalence of the replacement.

3. The machinery equipment provider satisfies this item in normal conditions, but in extraordinary conditions, the satisfying of this item is the responsibility of the system integrator. For example:

- The product will not break in normal operation, without a collision. However, the product can break in the event of a strong collision due to incorrect programming setup and safety setting during operation.

\* A – Scope Exceeded, B – Manufacturer Provided, C – May Require Additional Risk Reduction Measures

Number	Original Language Items	A*	B*	C*
1.1	Essential Requirements			
1.1.1	Definitions		X	X
1.1.2	Principles of safety integration		X	X
1.1.3	Materials and products		X	
1.1.4	Lighting			X
1.1.5	Design of machinery to facilitate its handling		X	
1.1.6	Ergonomics		X	X
1.1.7	Operating positions			X
1.1.8	Seating			X
1.2	Control Systems			
1.2.1	Safety and reliability of control systems		X	X
1.2.2	Control devices		X	X
1.2.3	Starting		X	X
1.2.4	Stopping		X	X
1.2.4.1	Normal stop		X	X
1.2.4.2	Operational stop		X	X
1.2.4.3	Emergency stop		X	X
1.2.4.4	Assembly of machinery			X
1.2.5	Selection of control or operating modes		X	X
1.2.6	Failure of the power supply			X
1.3	Protection against mechanical hazards			
1.3.1	Risk of loss of stability			X
1.3.2	Risk of break-up during operation		X	X
1.3.3	Risks due to falling or ejected objects		X	X
1.3.4	Risks due to surfaces, edges or angles		X	X
1.3.5	Risks related to combined machinery			X
1.3.6	Risks related to variations in operating conditions			X
1.3.7	Risks related to moving parts		X	X
1.3.8	Choice of protection against risks arising from moving parts			X
1.3.8.1	Moving transmission parts		X	X
1.3.8.2	Moving parts involved in the process		X	X
1.3.9	Risks of uncontrolled movements			X
1.4	Required characteristics of guards and protective devices			

1.4.1	General requirements			X
1.4.2	Special requirements for guards			X
1.4.2.1	Fixed guards			X
1.4.2.2	Interlocking movable guards			X
1.4.2.3	Adjustable guards restricting access			X
1.4.3	Special requirements for protective devices			X
1.5	Risks due to other hazards			
1.5.1	Electricity supply			X
1.5.2	Static electricity			X
1.5.3	Energy supply other than electricity			X
1.5.4	Errors of fitting			X
1.5.5	Extreme temperatures	X		
1.5.6	Fire	X		
1.5.7	Explosion	X		
1.5.8	Noise		X	X
1.5.9	Vibrations			X
1.5.10	Radiation	X		
1.5.11	External radiation			X
1.5.12	Laser radiation	X		
1.5.13	Emissions of hazardous materials and substances		X	X
1.5.14	Risk of being trapped in a machine			X
1.5.15	Risk of slipping, tripping or falling			X
1.5.16	Lightning			X
1.6	Maintenance			
1.6.1	Machinery maintenance			X
1.6.2	Access to operating positions and servicing points			X
1.6.3	Isolation of energy sources			X
1.6.4	Operator intervention			X
1.6.5	Cleaning of internal parts	X		
1.7	Information			
1.7.1	Information and warnings on the machinery		X	
1.7.1.1	Information and information devices		X	X
1.7.1.2	Warning devices		X	X
1.7.2	Warning of residual risks		X	
1.7.3	Marking of machinery		X	
1.7.4	Instructions		X	
1.7.4.1	General principles for the drafting of instructions		X	
1.7.4.2	Contents of the instructions		X	
1.7.4.3	Sales collateral	X		

Table 13: Declaration of Incorporation

# Appendix A. Certificate of Compliance and Declaration of Incorporation



## CERTIFICATE OF COMPLIANCE

Certificate No. MDC 2391

SGS Reference:	CST274791/1
Date of Issue:	13 <sup>th</sup> December 2019      Issue No.: 1      Expiry Date: 12 <sup>th</sup> December 2024
Scope of certification:	Assessment of the compliance of machinery with the Essential Health and Safety Requirements of the Machinery Directive 2006/42/EC, EN ISO 12100:2010, EN 60204-1:2006/AC:2010, EN ISO 13849-1:2015, EN ISO 10218-1:2011 and ISO/TS 15066:2016
Client/Applicant:	TECHMAN ROBOT Inc. 4F, No. 188, Wenhua 2nd Rd. Guishan Dist., Taoyuan City, Taiwan
Manufacturer:	Same as above
Designation of Machinery:	Industrial Robot
Type(s)/Model(s):	TM5-700, TM5M-700, TM5X-700, TM5MX-700, TM5-900, TM5M-900, TM5X-900, TM5MX-900, TM5-700 SEMI, TM5M-700 SEMI, TM5X-700 SEMI, TM5MX-700 SEMI, TM5-900 SEMI, TM5M-900 SEMI, TM5X-900 SEMI, TM5MX-900 SEMI, TM12, TM12M, TM12X, TM12MX, TM14, TM14M, TM14X, TM14MX, TM12 SEMI, TM12M SEMI, TM12X SEMI, TM12MX SEMI, TM14 SEMI, TM14M SEMI, TM14X SEMI, TM14MX SEMI
Serial Number(s):	N/A
Trade Mark/Name:	TECHMAN ROBOT
Technical File Reference:	TCF-TR20191203-V01, Dated 3 <sup>rd</sup> December 2019
Safety System Revision:	TECHMAN ROBOT Safety System 3.2
Compliance Approach:	The Technical File has been assessed against the Essential Health and Safety Requirements of Annex I of 2006/42/EC and relies in part on the application of Harmonised Standards as a means for demonstrating compliance. The following Harmonised Standards were applied, EN ISO 12100:2010, EN 60204-1:2006/AC:2010, EN ISO 13849-1:2015 and EN ISO 10218-1:2011. In addition further solutions were adopted as described in the Technical File, including the application of the following non harmonised standards ISO/TS 15066:2016, overall the approach adopted has been considered by SGS United Kingdom Limited
Conclusion:	In the opinion of SGS United Kingdom Limited the machinery type referred to above is compliant to the Essential Health and Safety Requirements of Annex I of the Machinery Directive 2006/42/EC
Authorised Signature Daniele Paoli Machinery Manager	 Page 1 of 1

The CE mark as shown below can be used after completion of an EC Declaration of Conformity and compliance with all relevant EC Directives.



This document is issued by the Company subject to its General Conditions of Service printed overleaf, available on request or accessible at <http://www.sgs.com/en/Terms-and-Conditions.aspx> and, for electronic format documents, subject to Terms and Conditions for Electronic Documents at <http://www.sgs.com/en/Terms-and-Conditions/Terms-e-Documents.aspx>.

Attention is drawn to the limitation of liability, indemnification and jurisdiction issues defined therein. Any holder of this document is advised that information contained hereon reflects the Company's findings at the time of its intervention only and within the limits of Client's instructions, if any. The Company's sole responsibility is to its Client and this document does not exonerate parties to a transaction from exercising all their rights and obligations under the transaction documents. This document cannot be reproduced except in full, without prior written approval of the Company. Any unauthorized alteration, forgery or falsification of the content or appearance of this document is unlawful and offenders may be prosecuted to the fullest extent of the law.

**SGS United Kingdom Limited**  
Unit 12A & 12b, Bowburn South Ind Est, Bowburn Durham, DH6 5AD Tel +44 (0)191 377 2000 Fax +44 (0)191 377 2020  
Registered in England No. 1193985 Rossmore Business Park, Ellesmere Port, Cheshire CH65 3EN [www.sgs.com](http://www.sgs.com)  
Member of SGS Group (SGS SA)

DU-CST-MA-022 Rev 2 (15/07/2019)

This document is issued, on the Client's behalf, by the Company under its General Conditions of Service printed overleaf. The Client's attention is drawn to the limitation of liability, indemnification and jurisdiction issues defined therein.

Any other holder of this document is advised that information contained hereon reflects the Company's findings at the time of its intervention only and within the limits of Clients instructions, if any. The Company's sole responsibility is to its Client and this document does not exonerate parties to a transaction from exercising all their rights and obligations under the transaction documents.

SGSPAPER  
19794655



The "manufacturer" in the article above should be deemed to be "original equipment manufacturer."



SGS

# CERTIFICATE OF COMPLIANCE

Certificate No. MDC 2392

SGS Reference: CST274791/1  
 Date of Issue: 13<sup>th</sup> December 2019 Issue No.: 1 Expiry Date: 12<sup>th</sup> December 2024  
 Scope of certification: Assessment of the compliance of machinery with the Essential Health and Safety Requirements of the Machinery Directive 2006/42/EC and EN ISO 13849-1  
 Client/Applicant: TECHMAN ROBOT Inc.  
 4F, No. 188, Wenhua 2nd Rd. Guishan Dist., Taoyuan City, Taiwan  
 Manufacturer: Same as above  
 Designation of Machinery: Industrial Robot  
 Type(s)/Model(s): TM5-700, TM5M-700, TM5X-700, TM5MX-700, TM5-900, TM5M-900, TM5X-900, TM5MX-900, TM5-700 SEMI, TM5M-700 SEMI, TM5X-700 SEMI, TM5MX-700 SEMI, TM5-900 SEMI, TM5M-900 SEMI, TM5X-900 SEMI, TM5MX-900 SEMI, TM12, TM12M, TM12X, TM12MX, TM14, TM14M, TM14X, TM14MX, TM12 SEMI, TM12M SEMI, TM12X SEMI, TM12MX SEMI, TM14 SEMI, TM14M SEMI, TM14X SEMI, TM14MX SEMI  
 Serial Number(s): N/A  
 Trade Mark/Name: TECHMAN ROBOT  
 Technical File Reference: TCF-TR20191203-V01, Dated 3<sup>rd</sup> December 2019  
 Safety System Revision: TECHMAN ROBOT Safety System 3.2  
 Compliance Approach: The Technical File has been assessed against the Essential Health and Safety Requirements of Annex I of 2006/42/EC and relies on the application of Harmonised Standards as a means for demonstrating compliance, the following Standards having been applied, EN ISO 13849-1:2015  
 Conclusion: In the opinion of SGS United Kingdom Limited the machinery type referred to above is compliant to the Essential Health and Safety Requirements of Annex I of the Machinery Directive 2006/42/EC and EN ISO 13849-1:2015 (SF0, SF1, SF10-SF14, SF16: PL=d, Cat3; SF2-SF9, SF15: PL=d, Cat2)  
 Authorised Signature: Daniele Paoli  
 Machinery Manager

Page 1 of 1

The CE mark as shown below can be used after completion of an EC Declaration of Conformity and compliance with all relevant EC Directives.



This document is issued by the Company subject to its General Conditions of Service printed overleaf, available on request or accessible at <http://www.sgs.com/en/Terms-and-Conditions.aspx> and, for electronic format documents, subject to Terms and Conditions for Electronic Documents at <http://www.sgs.com/en/Terms-and-Conditions/Terms-e-Document.aspx>.

Attention is drawn to the limitation of liability, indemnification and jurisdiction issues defined therein. Any holder of this document is advised that information contained hereon reflects the Company's findings at the time of its intervention only and within the limits of Client's instructions, if any. The Company's sole responsibility is to its Client and this document does not exonerate parties to a transaction from exercising all their rights and obligations under the transaction documents. This document cannot be reproduced except in full, without prior written approval of the Company. Any unauthorized alteration, forgery or falsification of the content or appearance of this document is unlawful and offenders may be prosecuted to the fullest extent of the law.

SGS United Kingdom Limited  
Unit 12A & 12b, Bowburn South Ind Est, Bowburn Durham, DH6 5AD Tel +44 (0)191 377 2000 Fax +44 (0)191 377 2020  
Registered in England No. 1193985 Rossmore Business Park, Ellesmere Port, Cheshire CH65 3EN [www.sgs.com](http://www.sgs.com)  
Member of SGS Group (SGS SA)

DU-CST-MA-022 Rev 2 (15/07/2019)

This document is issued, on the Client's behalf, by the Company under its General Conditions of Service printed overleaf. The Client's attention is drawn to the limitation of liability, indemnification and jurisdiction issues defined therein.

Any other holder of this document is advised that information contained hereon reflects the Company's findings at the time of its intervention only and within the limits of Client's instructions, if any. The Company's sole responsibility is to its Client and this document does not exonerate parties to a transaction from exercising all their rights and obligations under the transaction documents.

SGSPAPER  
19794654



The "manufacturer" in the article above should be deemed to be "original equipment manufacturer."



SGS

# CERTIFICATE OF COMPLIANCE

Certificate No. MDC 2393

SGS Reference: CST274791/1  
 Date of Issue: 13<sup>th</sup> December 2019 Issue No.: 1 Expiry Date: 12<sup>th</sup> December 2024  
 Scope of certification: Assessment of the compliance of machinery with the Essential Health and Safety Requirements of the Machinery Directive 2006/42/EC, EN ISO 10218-1:2011 and ISO/TS 15066:2016  
 Client/Applicant: TECHMAN ROBOT Inc.  
 4F, No. 188, Wenhua 2nd Rd. Guishan Dist., Taoyuan City, Taiwan  
 Manufacturer: Same as above  
 Designation of Machinery: Industrial Robot  
 Type(s)/Model(s): TM5-700, TM5M-700, TM5X-700, TM5MX-700, TM5-900, TM5M-900, TM5X-900, TM5MX-900, TM5-700 SEMI, TM5M-700 SEMI, TM5X-700 SEMI, TM5MX-700 SEMI, TM5-900 SEMI, TM5M-900 SEMI, TM5X-900 SEMI, TM5MX-900 SEMI, TM12, TM12M, TM12X, TM12MX, TM14, TM14M, TM14X, TM14MX, TM12 SEMI, TM12M SEMI, TM12X SEMI, TM12MX SEMI, TM14 SEMI, TM14M SEMI, TM14X SEMI, TM14MX SEMI  
 Serial Number(s): N/A  
 Trade Mark/Name: TECHMAN ROBOT  
 Technical File Reference: TCF-TR20191203-V01, Dated 3<sup>rd</sup> December 2019  
 Safety System Revision: TECHMAN ROBOT Safety System 3.2  
 Compliance Approach: The Technical File has been assessed against the Essential Health and Safety Requirements of Annex I of 2006/42/EC and relies in part on the application of Harmonised Standards as a means for demonstrating compliance. The following Harmonised Standards were applied, EN ISO 10218-1:2011. In addition further solutions were adopted as described in the Technical File, including the application of the following non harmonised standards ISO/TS 15066:2016, overall the approach adopted has been considered by SGS United Kingdom Limited

Conclusion: In the opinion of SGS United Kingdom Limited the machinery type referred to above is compliant to the Essential Health and Safety Requirements of Annex I of the Machinery Directive 2006/42/EC, EN ISO 10218-1:2011 and ISO/TS 15066:2016

Authorised Signature  
 Daniele Paoli  
 Machinery Manager

Page 1 of 1

The CE mark as shown below can be used after completion of an EC Declaration of Conformity and compliance with all relevant EC Directives.



This document is issued by the Company subject to its General Conditions of Service printed overleaf, available on request or accessible at <http://www.sgs.com/en/Terms-and-Conditions.aspx> and, for electronic format documents, subject to Terms and Conditions for Electronic Documents at <http://www.sgs.com/en/Terms-and-Conditions/Terms-e-Document.aspx>.

Attention is drawn to the limitation of liability, indemnification and jurisdiction issues defined therein. Any holder of this document is advised that information contained hereon reflects the Company's findings at the time of its intervention only and within the limits of Client's instructions, if any. The Company's sole responsibility is to its Client and this document does not exonerate parties to a transaction from exercising all their rights and obligations under the transaction documents. This document cannot be reproduced except in full, without prior written approval of the Company. Any unauthorized alteration, forgery or falsification of the content or appearance of this document is unlawful and offenders may be prosecuted to the fullest extent of the law."

SGS United Kingdom Limited  
 Unit 12A & 12b, Bowburn South Ind Est, Bowburn Durham, DH6 5AD Tel +44 (0)191 377 2000 Fax +44 (0)191 377 2020  
 Registered in England No. 1193985 Rossmore Business Park, Ellesmere Port, Cheshire CH65 3EN [www.sgs.com](http://www.sgs.com)  
 Member of SGS Group (SGS SA)

This document is issued, on the Client's behalf, by the Company under its General Conditions of Service printed overleaf. The Client's attention is drawn to the limitation of liability, indemnification and jurisdiction issues defined therein.

DU-CST-MA-022 Rev 2 (15/07/2019)

Any other holder of this document is advised that information contained hereon reflects the Company's findings at the time of its intervention only and within the limits of Clients instructions, if any. The Company's sole responsibility is to its Client and this document does not exonerate parties to a transaction from exercising all their rights and obligations under the transaction documents.

SGSPAPER  
 19794656



The "manufacturer" in the article above should be deemed to be "original equipment manufacturer."

# DECLARATION OF INCORPORATION

We **TECHMAN ROBOT Inc.**  
**4F, No. 188, Wenhua 2nd Rd. Guishan Dist., Taoyuan City, Taiwan**

Declare that the

Product name: Industrial Robot

Series Model Number:

TM5-700; TM5M-700; TM5X-700; TM5MX-700; TM5-900; TM5M-900; TM5X-900; TM5MX-900;  
TM5-700 SEMI; TM5M-700 SEMI; TM5X-700 SEMI; TM5MX-700 SEMI; TM5-900 SEMI;  
TM5M-900 SEMI; TM5X-900 SEMI; TM5MX-900 SEMI;  
TM12; TM12M; TM12X; TM12MX; TM14; TM14M; TM14X; TM14MX;  
TM12 SEMI; TM12M SEMI; TM12X SEMI; TM12MX SEMI; TM14 SEMI; TM14M SEMI; TM14X SEMI; TM14MX SEMI;

Conform to the essential safety requirements of the relevant European Directive:

- Machinery Directive 2006/42/EC
- Electromagnetic Compatibility Directive 2014/30/EU
- Low Voltage Directive 2014/35/EU

The following essential requirements of EC Machinery Directive 2006/42/EC have been applied:

Clause 1.1.2, 1.1.3, 1.1.5, 1.1.6, 1.1.7, 1.2.1, 1.2.2, 1.2.3, 1.2.4.1, 1.2.4.2, 1.2.4.3, 1.2.4.4, 1.2.5, 1.2.6, 1.3.1, 1.3.2,  
1.3.4, 1.3.6, 1.3.7, 1.3.8.1, 1.3.8.2, 1.3.9, 1.4.1, 1.4.2.1, 1.4.3, 1.5.1, 1.5.2, 1.5.3, 1.5.4, 1.5.13, 1.5.14, 1.6.1,  
1.6.2, 1.6.3, 1.6.4, 1.6.5, 1.7.1.1, 1.7.1.2, 1.7.2, 1.7.3, 1.7.4, 1.7.4.1, 1.7.4.2, 1.7.4.3

The person who compile technical file established within the EU:

Name: SGS UK

Address: SGS United Kingdom Rossmore Business Park, Ellesmere Port, Cheshire CH65 3EN

Mounting and connecting instructions defined in catalogues and technical construction files must be respected by the user.

They are based on the following standards :

- EN ISO 12100: 2010 / Safety of Machinery - General principles for design / Risk Assessment and Risk reduction.
- EN 60204-1:2006/AC:2010 / Safety of machinery - Electrical equipment of machines - Part 1: General requirements
- EN ISO 13849-1:2015 / Safety of machinery - Safety-related parts of control systems Part 1: General principles for design
- EN ISO 10218-1:2011 / Robots and robotic devices - Safety requirements for industrial robots - Part 1: Robots
- ISO TS 15066-2016 / Robots and robotic devices — Collaborative robots
- EN 61000-6-2:2005 / Electromagnetic compatibility (EMC) - Part 6-2: Generic standards - Immunity for industrial environments
- EN 61000-6-4:2007/ A1:2011 / Electromagnetic compatibility (EMC) - Part 6-4: Generic standards - Emission standard for industrial environments.

The relevant technical documentation has been compiled in accordance with Annex VII, Part B of EC Machinery Directive 2006/42/EC. We undertake, in response to a reasoned request, to supply it to the market surveillance authorities within a reasonable period.

The partly completed machinery must not be put into service until the final machinery into which it is to be incorporated has been declared in conformity with the provisions of the Machinery Directive.

Authorized Signature :   
Name : Haw Chen  
Responsibility : CEO  
Date : April 25, 2018  
Place : Taiwan

## Appendix B. Verifications of EMC Compliance



SGS Reference No: MH/2018/50140C

### VERIFICATION OF EMC COMPLIANCE

Verification No. : MH/2018/50140C  
Representative Model No. : TM14M  
Added Model(s) : TM5M-700, TM5MX-700, TM5M-900, TM5MX-900,  
TM5M-700 SEMI, TM5MX-700 SEMI, TM5M-900 SEMI,  
TM5MX-900 SEMI, TM12M, TM12MX, TM14M, TM14MX,  
TM12M SEMI, TM12MX SEMI, TM14M SEMI, TM14MX SEMI  
Product Name : Industrial Robot  
Brand Name : Techman Robot Inc.  
Applicant : Techman Robot Inc.  
Address of Applicant : 4F, No. 188, Wenhua 2nd Rd. Guishan Dist., Taoyuan City, Taiwan  
Test Report Number : MH/2018/50140  
Date of Issue : Aug. 06, 2018  
Applicable Standards : EN 61000-6-4 : 2007+A1:2011  
EN 61000-6-2 : 2017  
IEC 61000-4-2 : 2008, IEC 61000-4-3 : 2006+A1:2007+A2:2010  
IEC 61000-4-4 : 2012, IEC 61000-4-5 : 2014  
IEC 61000-4-6 : 2013, IEC 61000-4-8 : 2009

#### Conclusion

The apparatus meets the requirements of the above standards. In addition, this verification is only valid for the equipment and configuration described and in conjunction with the test report as detailed above.

Authorized Signatory:



SGS TAIWAN LTD.  
Eddy Cheng  
Technical Asst. Supervisor

Unless otherwise stated the results shown in this test report refer only to the sample(s) tested and such sample(s) are retained for 90 days only.

除非另有說明，此報告結果僅針對測試之樣品負責，同時此樣品僅保留90天，本報告未經本公司書面許可，不可部份複製。

This document is issued by the Company subject to its General Conditions of Service printed overleaf, available on request or accessible at [www.sgs.com/terms\\_and\\_conditions.htm](http://www.sgs.com/terms_and_conditions.htm) and for electronic format documents, subject to Terms and Conditions for Electronic Documents at [www.sgs.com/terms\\_e-document.htm](http://www.sgs.com/terms_e-document.htm). Attention is drawn to the limitation of liability, indemnification and jurisdiction issues defined therein. Any holder of this document is advised that information contained hereon reflects the Company's findings at the time of its intervention only and within the limits of Client's instructions, if any. The Company's sole responsibility is to its Client and this document does not exonerate parties to a transaction from exercising all their rights and obligations under the transaction documents. This document cannot be reproduced except in full, without prior written approval of the Company. Any unauthorized alteration, forgery or falsification of the content or appearance of this document is unlawful and offenders may be prosecuted to the fullest extent of the law.

SGS Taiwan Ltd.  
台灣檢驗科技股份有限公司

No. 134, Wu Kung Road, New Taipei Industrial Park, WuKu District, New Taipei City, Taiwan 24803/新北市五股區新北產業園區五工路 134 號

t (886-2) 2299-3279

f (886-2) 2298-0488

[www.tw.sgs.com](http://www.tw.sgs.com)

Member of SGS Group





SGS Reference No: MH/2018/30017C

## VERIFICATION OF EMC COMPLIANCE

Verification No. : MH/2018/30017C  
Representative Model No. : TM12  
Added Model(s) : TM5-700; TM5X-700; TM5-900; TM5X-900; TM5-700 SEMI; TM5X-700 SEMI; TM5-900 SEMI; TM5X-900 SEMI; TM12; TM12X; TM14; TM14X; TM12 SEMI; TM12X SEMI; TM14 SEMI; TM14X SEMI  
Product Name : Industrial Robot  
Brand Name : TECHMAN ROBOT INC  
Applicant : Techman Robot Inc.  
Address of Applicant : 4F, No. 188, Wenhua 2nd Rd. Guishan Dist., Taoyuan City, Taiwan  
Test Report Number : MH/2018/30017  
Date of Issue : May 02, 2018  
Applicable Standards : EN 61000-6-4 : 2007+A1:2011  
EN 61000-6-2 : 2005+AC:2005  
IEC 61000-4-2 : 2008, IEC 61000-4-3 : 2006+A1:2007+A2:2010  
IEC 61000-4-4 : 2012, IEC 61000-4-5 : 2014  
IEC 61000-4-6 : 2013, IEC 61000-4-8 : 2009, IEC 61000-4-11 : 2004

### Conclusion

The apparatus meets the requirements of the above standards. In addition, this verification is only valid for the equipment and configuration described and in conjunction with the test report as detailed above.

Authorized Signatory:

SGS TAIWAN LTD.  
Eddy Cheng  
Technical Asst. Supervisor

Unless otherwise stated the results shown in this test report refer only to the sample(s) tested and such sample(s) are retained for 90 days only.

除非另有說明，此報告結果僅對測試之樣品負責，同時此樣品僅保留90天，本報告未經本公司書面許可，不可部份複製。

This document is issued by the Company subject to its General Conditions of Service printed overleaf, available on request or accessible at [www.sgs.com/terms\\_and\\_conditions.htm](http://www.sgs.com/terms_and_conditions.htm) and for electronic format documents, subject to Terms and Conditions for Electronic Documents at [www.sgs.com/terms\\_e-document.htm](http://www.sgs.com/terms_e-document.htm). Attention is drawn to the limitation of liability, indemnification and jurisdiction issues defined therein. Any holder of this document is advised that information contained hereon reflects the Company's findings at the time of its intervention only and within the limits of Client's instructions, if any. The Company's sole responsibility is to its Client and this document does not exonerate parties to a transaction from exercising all their rights and obligations under the transaction documents. This document cannot be reproduced except in full, without prior written approval of the Company. Any unauthorized alteration, forgery or falsification of the content or appearance of this document is unlawful and offenders may be prosecuted to the fullest extent of the law.

SGS Taiwan Ltd. No. 134, Wu Kung Road, New Taipei Industrial Park, Wuku District, New Taipei City, Taiwan 24803/新北市五股區新莊產業園區五工路134號  
台灣檢驗科技股份有限公司 t (886-2) 2299-3279 f (886-2) 2298-0488 www.tw.sgs.com

Member of SGS Group

## Appendix C. TM Robot Stopping Time and Distance for all Series Product Models

The stopping time and stopping distance of the Cat.1 stop functions of this product at different speeds and with different payloads are shown below.



**WARNING:**

Any moving robot requires some distance to stop. When stopping a robot, make sure that there is no interference with other equipment. This requires more distance at high operating speeds or with heavier payloads.

### TM5-700 Series

Stop Time and Stop Distance Table								
Percentage of Maximum Payload ( % )	Extension(%)	Speed(%)	First joint		Second joint		Third joint	
			Stop Time (ms)	Stop Distance (deg)	Stop Time (ms)	Stop Distance (deg)	Stop Time (ms)	Stop Distance (deg)
33	33	33	364	9.00	600	9.29	442	8.97
		66	377	17.96	516	18.15	466	17.91
		100	381	26.55	657	27.13	486	26.92
	66	33	455	8.99	567	9.17	422	8.96
		66	531	17.95	594	18.08	457	17.94
		100	610	26.34	528	27.72	457	23.41
	100	33	367	8.98	534	9.30	432	9.00
		66	396	17.94	501	18.19	530	18.02
		100	427	26.76	526	27.80	541	28.81
66	33	33	378	9.01	531	9.23	475	8.99
		66	401	17.95	547	18.12	478	17.97
		100	575	26.75	551	26.99	570	26.91
	66	33	496	8.96	529	9.29	433	8.97
		66	545	17.96	506	18.14	526	17.98
		100	563	26.46	526	28.36	583	27.73
	100	33	517	8.94	568	9.38	636	9.08
		66	598	17.90	524	18.10	545	18.16
		100	614	26.58	575	28.53	527	28.75
100	33	33	565	8.96	585	9.26	567	9.12
		66	570	17.92	585	18.16	675	18.28
		100	579	26.33	356	30.98	666	27.40
	66	33	566	8.95	588	9.34	625	9.28
		66	576	17.92	578	18.26	656	18.26
		100	570	26.88	343	31.10	550	27.56
	100	33	597	8.94	576	9.34	681	9.34
		66	593	17.86	516	18.14	555	18.09
		100	596	26.00	544	26.45	528	28.80

Table 14: Stopping Time and Distance for TM5-700 Series

**TM5-900 Series**

Stop Time and Stop Distance Table								
Percentage of Maximum Payload ( % )	Extension(%)	Speed(%)	First joint		Second joint		Third joint	
			Stop Time (ms)	Stop Distance (deg)	Stop Time (ms)	Stop Distance (deg)	Stop Time (ms)	Stop Distance (deg)
33	33	33	519	8.96	626	9.24	457	8.99
		66	512	17.95	555	18.03	475	17.93
		100	466	25.68	563	27.20	476	27.09
	66	33	374	8.97	598	9.32	444	8.96
		66	719	17.95	510	18.11	636	18.12
		100	664	26.33	521	27.34	650	27.41
	100	33	366	8.98	524	9.25	428	8.97
		66	412	17.93	518	18.23	510	18.04
		100	442	26.57	508	24.20	498	28.66
66	33	33	508	8.98	660	9.19	629	9.23
		66	589	17.97	666	18.20	536	18.09
		100	476	26.86	575	27.62	635	27.06
	66	33	635	8.93	633	9.27	518	9.00
		66	645	18.00	640	18.16	647	18.19
		100	668	26.73	569	28.14	676	27.73
	100	33	366	9.02	506	9.22	565	8.96
		66	479	17.96	522	18.16	514	16.93
		100	503	26.58	517	23.61	485	28.62
100	33	33	474	8.99	572	9.15	662	9.21
		66	571	18.02	573	18.22	640	18.18
		100	568	26.94	563	28.00	637	27.36
	66	33	508	9.00	691	9.31	627	9.18
		66	566	18.10	641	18.23	652	18.26
		100	583	26.72	534	28.45	680	27.56
	100	33	549	9.04	542	9.28	436	8.97
		66	645	18.16	551	18.11	520	18.13
		100	594	26.60	569	23.15	499	28.78

Table 15: Stopping Time and Distance for TM5-900 Series

**TM14 Series**

Stop Time and Stop Distance Table								
Percentage of Maximum Payload ( % )	Extension(%)	Speed(%)	First joint		Second joint		Third joint	
			Stop Time (ms)	Stop Distance (deg)	Stop Time (ms)	Stop Distance (deg)	Stop Time (ms)	Stop Distance (deg)
33	33	33	416	6.01	554	6.18	511	8.83
		66	662	12.00	650	12.33	621	17.84
		100	482	18.24	635	18.58	510	26.32
	66	33	374	5.99	637	6.41	527	8.94
		66	643	11.99	641	12.34	689	17.66
		100	644	18.18	654	18.65	545	26.54
	100	33	482	6.04	530	6.27	453	8.42
		66	531	11.90	657	12.37	589	18.28
		100	624	18.17	626	17.64	575	28.86
66	33	33	680	6.00	623	6.36	598	9.17
		66	684	11.98	605	12.20	632	18.91
		100	690	18.13	595	18.54	631	27.19
	66	33	595	5.99	576	6.35	635	9.28
		66	597	11.96	557	12.42	600	18.33
		100	581	18.13	557	18.51	599	27.50
	100	33	548	5.98	530	6.38	432	8.52
		66	568	11.84	576	12.41	567	18.32
		100	568	18.25	589	17.75	531	28.77
100	33	33	591	5.99	574	6.34	529	9.10
		66	608	11.97	575	12.38	557	18.22
		100	582	18.15	585	18.89	556	27.27
	66	33	611	5.99	594	6.48	575	9.12
		66	615	11.99	616	12.26	671	18.30
		100	618	18.23	604	18.98	571	27.34
	100	33	570	6.06	568	6.29	575	8.95
		66	567	12.06	552	12.34	587	18.20
		100	568	18.39	591	17.61	544	28.87

Table 16: Stopping Time and Distance for TM14 Series

**TM12 Series**

Stop Time and Stop Distance Table								
Percentage of Maximum Payload ( % )	Extension(%)	Speed(%)	First joint		Second joint		Third joint	
			Stop Time (ms)	Stop Distance (deg)	Stop Time (ms)	Stop Distance (deg)	Stop Time (ms)	Stop Distance (deg)
33	33	33	365	6.02	634	6.27	674	9.35
		66	364	12.00	557	12.18	588	18.12
		100	473	18.20	559	18.48	615	27.26
	66	33	368	6.01	563	6.27	584	9.19
		66	634	12.01	531	12.24	653	18.30
		100	621	18.17	541	18.45	552	27.73
	100	33	541	5.98	597	5.22	544	8.94
		66	564	12.01	587	12.21	532	18.14
		100	591	18.17	592	17.80	569	28.90
66	33	33	662	6.02	644	6.16	632	9.20
		66	657	12.01	645	12.26	657	18.10
		100	659	18.16	666	18.67	695	27.08
	66	33	501	6.03	664	6.12	680	9.36
		66	661	12.00	601	12.33	676	18.30
		100	661	18.16	588	18.91	570	27.50
	100	33	539	6.02	545	6.38	513	9.10
		66	543	12.01	545	12.36	520	18.15
		100	530	18.40	565	17.88	591	28.82
100	33	33	584	5.99	540	6.19	606	9.17
		66	596	11.99	560	12.52	592	18.01
		100	603	18.14	535	18.88	572	27.07
	66	33	579	6.06	549	6.26	613	9.33
		66	581	12.09	564	12.52	606	18.12
		100	585	18.27	556	19.24	582	27.75
	100	33	580	6.06	558	5.36	608	9.34
		66	548	12.12	537	12.39	547	18.15
		100	564	18.41	518	18.14	611	27.50

Table 17: Stopping Time and Distance for TM12 Series

# TECHMAN ROBOT



[www.tm-robot.com](http://www.tm-robot.com)