

Precise Stable Durability High Rigidity

Meet the Multi-Demand of Accuracy and Efficiency

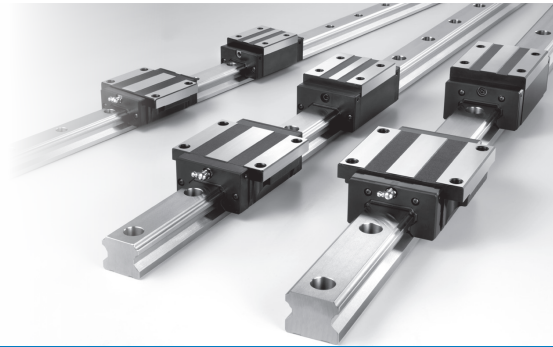

Linear Guideway

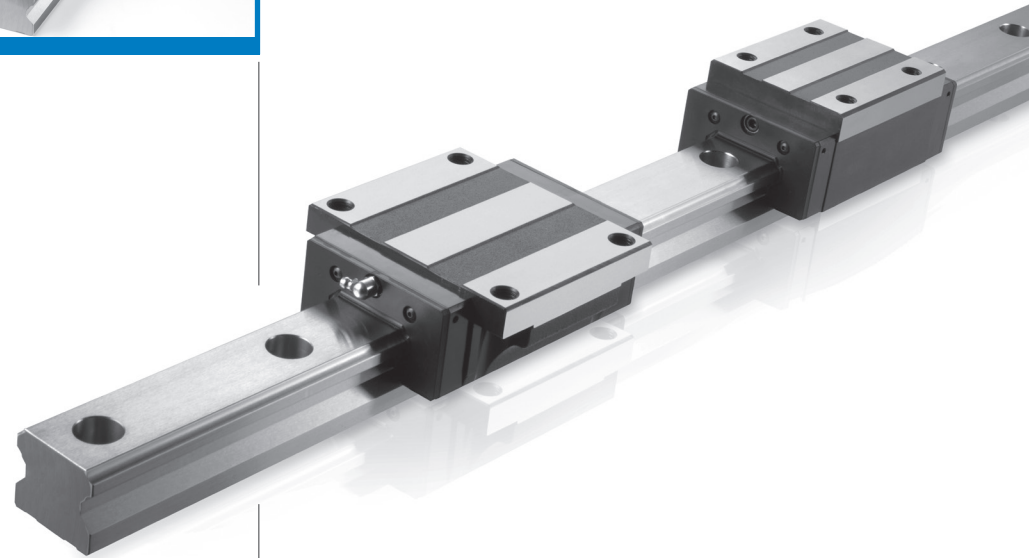

(1) High positioning accuracy, high repeatability

The *PMI* linear guideway is a design of rolling motion with a low friction coefficient, and the difference between dynamic and static friction is very small. Therefore, the stick-slip will not occur when submicron feeding is making.

(2) Low frictional resistance, high precision maintained for long period

The frictional resistance of a linear guideway is only 1/20th to 1/40th of that in a slide guide. With a linear guideway, a well lubrication can be easily achieved by supplying grease through the grease nipple on carriage or utilizing a centralized oil pumping system, thus the frictional resistance is decreased and the accuracy could be maintained for long period.

(3) High rigidity with four-way load design

The optimum design of geometric mechanics makes the linear guideway to bear the load in all four directions, radial, reversed radial, and two lateral directions. Furthermore, the rigidity of linear guideway could be easily achieved by preloading carriage and by adding the number of carriages.

(4) Suitable for high speed operation

Due to the characteristic of low frictional resistance, the required driving force is much lower than in other systems, thus the power consumption is small. Moreover, the temperature rising effect is small even under high speed operation.

(5) Easy installation with interchangeability

Compared with the high-skill required scrapping process of conventional slide guide, the linear guideway can offer high precision even if the mounting surface is machined by milling or grinding. Moreover the interchangeability of linear guideway gives a convenience for installation and future maintenance.

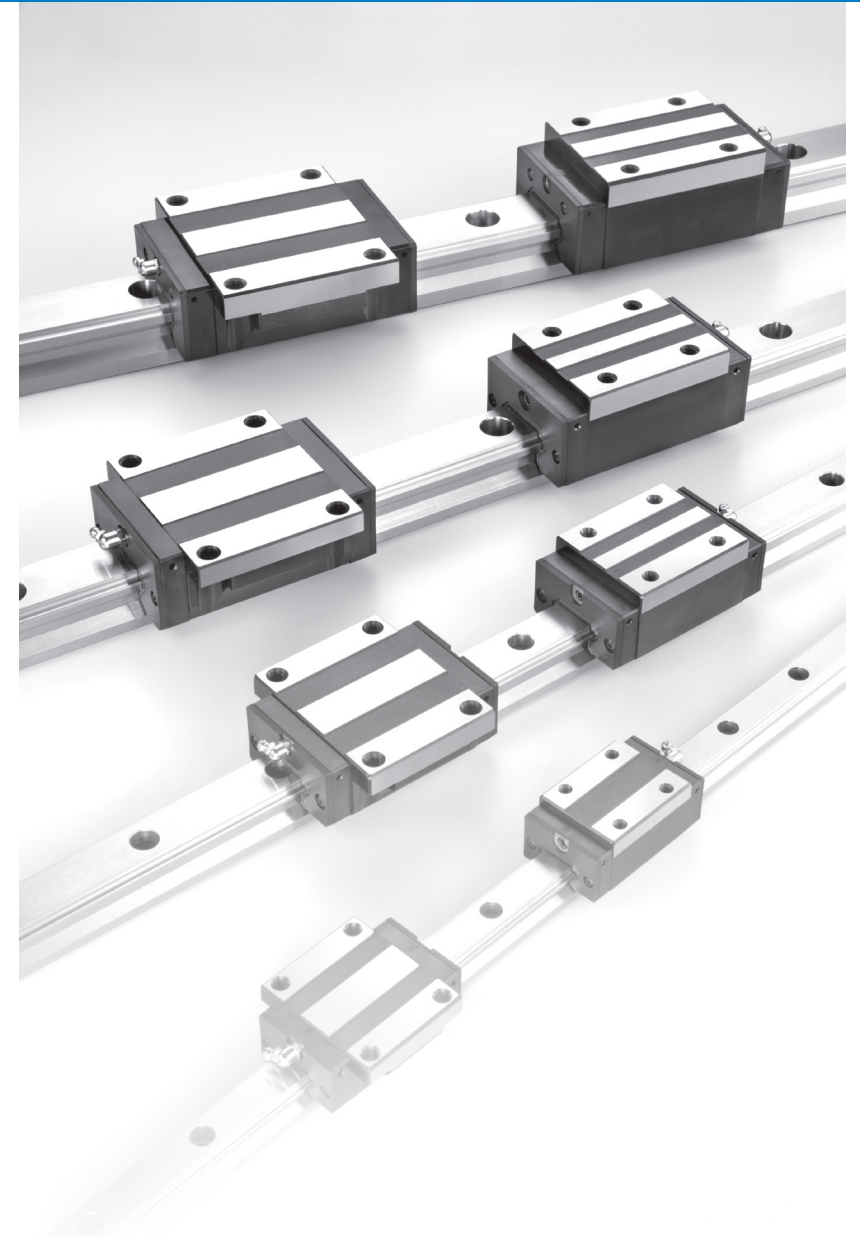

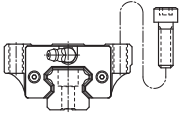
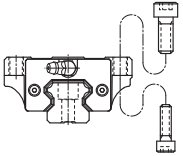
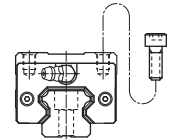
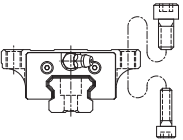
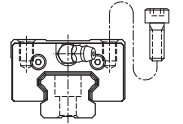
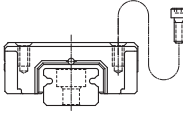
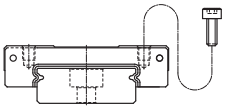
Type	Model	Characteristics	Major Application
Full Ball, Heavy Load Type	MSA-A MSA-LA		<ul style="list-style-type: none"> • Heavy Load, High Rigidity • Self Alignment Capability • Smooth Movement • Low Noise • Interchangeability <p>Machine Center, NC lathe, XYZ axes of heavy cutting machine tools, Grinding head feeding axis of grinding machines, Milling machine, Z axis of boring machine and machine tools, EDM, Z axis of industrial machine, Measuring equipment, Precision XY table, Welding machine, Binding machine, Auto packing machine</p>
	MSA-E MSA-LE		
	MSA-S MSA-LS		
Full Ball, Compact Type	MSB-TE MSB-E		<ul style="list-style-type: none"> • Compact, High Load • Self Alignment Capability • Smooth Movement • Low Noise • Interchangeability
	MSB-TS MSB-S		
Full Ball, Miniature Type	MSC		<ul style="list-style-type: none"> • Ultra Compact • Smooth Movement • Low Noise • Ball Retainer • Interchangeability <p>IC/LSI manufacturing machine, Hard disc drive, Slide unit of OA equipment, Wafer transfer equipment, Printed circuit board assembly table, Medical equipment, Inspection equipment</p>
	MSD		

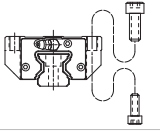
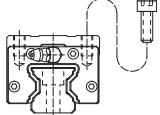
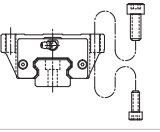
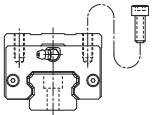
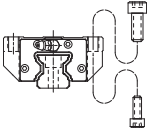
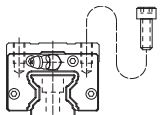
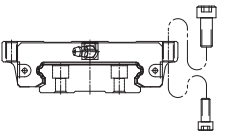
Type	Model		Characteristics	Major Application
Full Roller, Heavy Load Type	MSR-E		<ul style="list-style-type: none"> • Ultra Heavy Load • Ultra High Rigidity • Smooth Movement • Low Noise • Good Lubricant Effect 	Machine Center, NC lathe, Grinding machine, Five axes milling machine, Jig borer, Drilling machine, Horizontal milling machine, Mold processing machine, EDM
	MSR-LE			
	MSR-S			
	MSR-LS			
Ball Chain, Heavy Load Type	SME-E		<ul style="list-style-type: none"> • Heavy Load, High Rigidity • Self Alignment Capability • Ball Chain Design • Smooth Movement • Low Noise, Good Lubricant Effect • Interchangeability 	Machine Center, NC lathe, XYZ axes of heavy cutting machine tools, Grinding head feeding axis of grinding machines, milling machine, Z axis of boring machine and machine tools, EDM, Z axis of industrial machine, Measuring equipment, Precision XY table, Welding machine, Binding machine, Auto packing machine
	SME-LE			
	SME-S			
	SME-LS			
Roller Chain, Heavy Load Type	SMR-E		<ul style="list-style-type: none"> • Ultra Heavy Load • Ultra High Rigidity • Roller Chain Design • Smooth Movement • Low Noise • Good Lubricant Effect 	Machine Center, NC lathe, Grinding machine, Five axes milling machine, Jig borer, Drilling machine, Horizontal milling machine, Mold processing machine, EDM
	SMR-LE			
	SMR-S			
	SMR-LS			
Full Ball Wide Rail type	MSG-E		<ul style="list-style-type: none"> • Heavy Load, High Rigidity • Self Alignment Capability • Smooth Movement • Low Noise • Interchangeability 	Machine Center, Auto packing machine, Binding machine, laser cutting machine
	MSG-S			

3 The Procedure of Select Linear Guideway

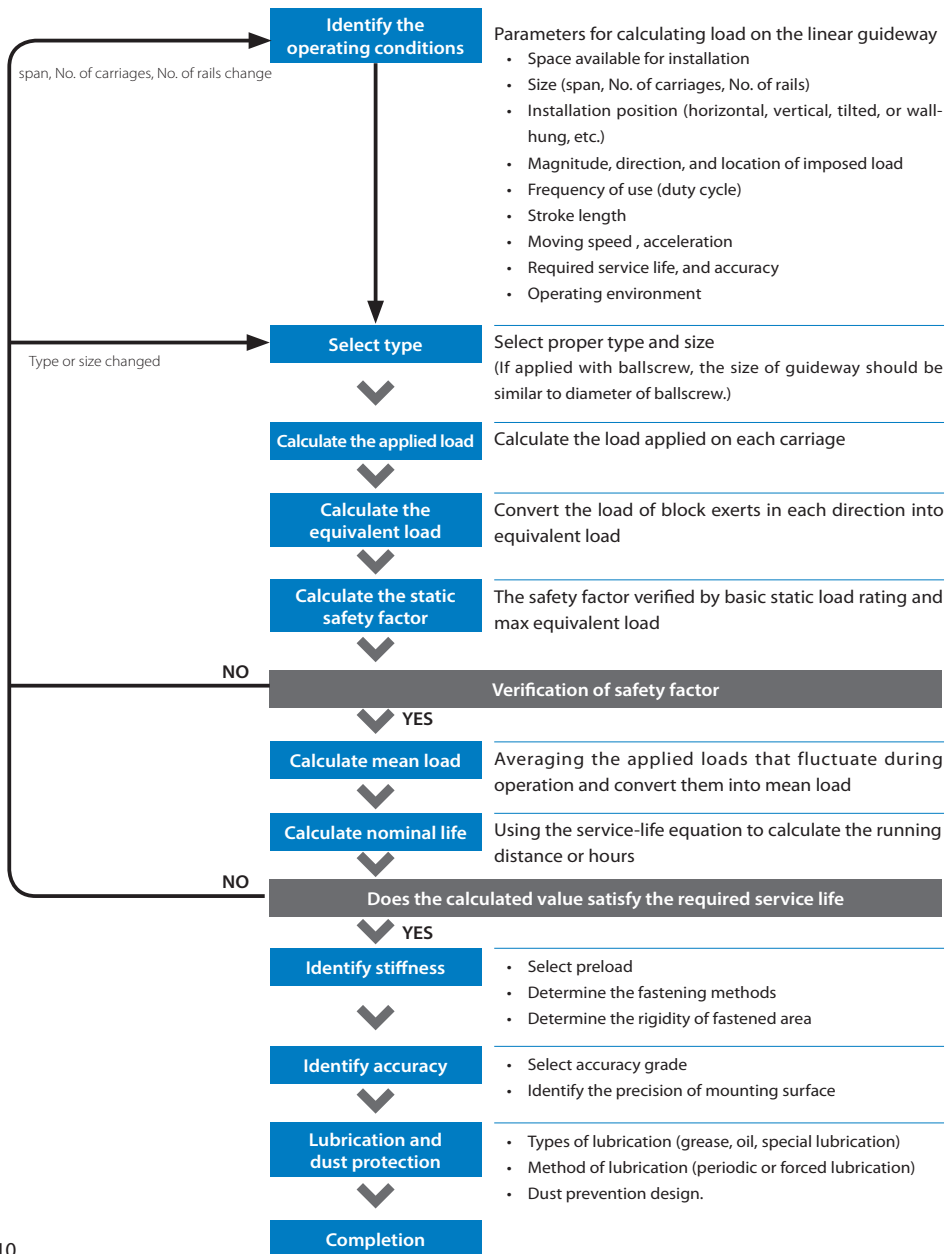

4 Load Rating and Service Life of Linear Guideway

To obtain a model which is most suitable for your service conditions of the linear guideway system, the load capacity and service life of the model must be taken into consideration. To verify the static load capacity, the basic static load rating (C_0) is taken to obtain the static safety factor. The service life can be obtained by calculating the nominal life based on basic dynamic load rating. As the raceways or rolling elements are subjected repeated stresses, the service life of a linear guideway is defined as the total running distance that the linear guideway travel until flaking occurs.

4.1 Basic Static Load Rating(C_0)

A localized permanent deformation will develop between raceways and rolling elements when a linear guideway receives an excessive load or a large impact. If the magnitude of the deformation exceeds a certain limit, it could obstruct the smooth motion of the linear guideway. The basic static load rating (C_0) refers to a static load in a given direction with a specific magnitude applied at the contact area under the most stress where the sum of permanent deformation develops between the raceway and rolling elements is 0.0001 times of the diameter of rolling ball. Therefore, the basic static load rating sets a limit on the static permissible load.

4.2 Static Permissible Moment (M_0)

When a moment is applied to a linear guideway, the rolling balls on both ends will receive the most stress among the stress distribution over the rolling elements in the system. The static permissible moment (M_0) refers to a static moment in a given direction with specific magnitude applied at the contact area under the most stress where the sum of permanent deformation develops between the raceway and rolling elements is 0.0001 times the diameter of rolling elements. Therefore, the static permissible moment sets a limit on the static moment. In linear guideway system, the static permissible moment is defined as M_P , M_Y , M_R three directions. See the figure below.

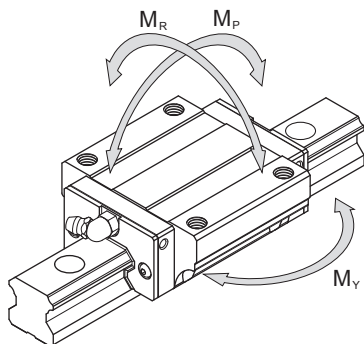

4.3 Static Safety Factor (f_s)

Due to the impact and vibration while the guideway at rest or moving, or the inertia from start and stop, the linear guideway may encounter with an unexpected external force. Therefore, the safety factor should be taken into consideration for effects of such operating loads. The static safety factor (f_s) is a ratio of the basic static load rating (C_0) to the calculated working load. The static safety factor for different kinds of application is shown as Table.

$$f_s = \frac{C_0}{P} \quad \text{or} \quad f_s = \frac{M_0}{M}$$

f_s Static safety factor

C_0 Basic static load rating (N)

M_0 Static permissible moment (N · m)

P Calculated working load (N)

M Calculated moment (N · m)

Machine Type	Load Condition	f_s (Lower limit)
Regular industrial machine	Normal loading condition	1.0 ~ 1.3
	With impact and vibration	2.0 ~ 3.0
Machine tool	Normal loading condition	1.0 ~ 1.5
	With impact and vibration	2.5 ~ 7.0

Standard value of static safety factor

4.4 Basic Dynamic Load Rating (C)

Even when identical linear guideways in a group are manufactured in the same way or applied under the same condition, the service life may be varied. Thus, the service life is used as an indicator for determining the service life of a linear guideway system. The nominal life (L) is defined as the total running distance that 90% of identical linear guideways in a group, when they are applied under the same conditions, can work without developing flaking. The basic dynamic load rating (C) can be used to calculate the service life when linear guideway system response to a load. The basic dynamic load rating (C) is defined as a load in a given direction and with a given magnitude that when a group of linear guideways operate under the same conditions. As the rolling element is ball, the nominal life of the linear guideway is 50 km. Moreover, as the rolling element is roller, the nominal life is 100 km.

4.5 Calculation of Nominal Life (L)

The nominal life of a linear guideway can be affected by the actual working load. The nominal life can be calculated base on selected basic dynamic load rating and actual working load. The nominal life of linear guideway system could be influenced widely by environmental factors such like hardness of raceway, environmental temperature, motion conditions, thus these factors should be considered for calculation of nominal life.

$$\text{Ball} \quad L = \left(\frac{f_H \times f_T}{f_W} \times \frac{C}{P} \right)^3 \times 50$$

$$\text{Roller} \quad L = \left(\frac{f_H \times f_T}{f_W} \times \frac{C}{P} \right)^{\frac{10}{3}} \times 100$$

L Nominal life (km)

C Basic dynamic load rating (N)

P Working load (N)

f_H Hardness factor

f_T Temperature factor

f_W Load factor

Hardness factor f_H

In order to ensure the optimum load capacity of linear guideway system, the hardness of raceway must be HRC58~64. If the hardness is lower than this range, the permissible load and nominal life will be decreased. For this reason, the basic dynamic load rating and the basic static load rating should be multiplied by hardness factor for rating calculation. See figure below. The hardness requirement of **PMI** linear guideway is above HRC58, thus the $f_H=1.0$.

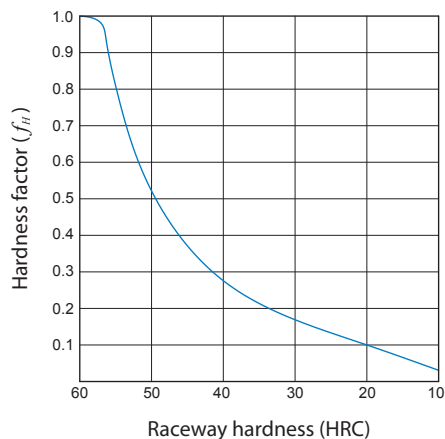

Temperature factor f_T

When operating temperature higher than 100°C, the nominal life will be degraded. Therefore, the basic dynamic and static load rating should be multiplied by temperature factor for rating calculation. See figure below. The assemble parts of **PMI** guideway are made of plastic and rubber, therefore, the operating temperature below 100°C is strongly recommend. For special need, please contact us.

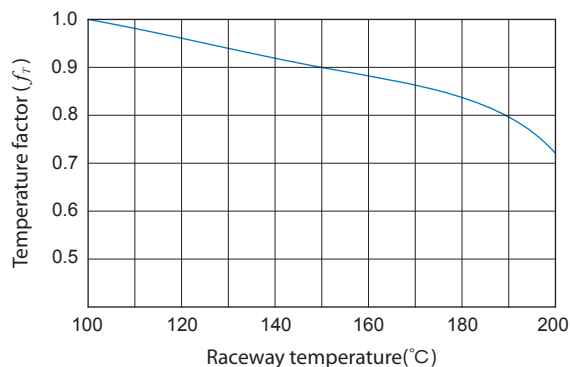

Load factor f_w

Although the working load of liner guideway system can be obtained by calculation, the actual load is mostly higher than calculated value. This is because the vibration and impact, caused by mechanical reciprocal motion, are difficult to be estimated. This is especially true when the vibration from high speed operation and the impact from repeated start and stop. Therefore, for consideration of speed and vibration, the basic dynamic load rating should be divided by the empirical load factor. See the table below.

Motion Condition	Operating Speed	f_w
No impact & vibration	$V \leq 15 \text{ m/min}$	1.0~1.2
Slight impact & vibration	$15 < V \leq 60 \text{ m/min}$	1.2~1.5
Moderate impact & vibration	$60 < V \leq 120 \text{ m/min}$	1.5~2.0
Strong impact & vibration	$V \geq 120 \text{ m/min}$	2.0~3.5

4.6 Calculation of Service Life in Time (L_h)

When the nominal life (L) is obtained, the service life in hours can be calculated by using the following equation when stroke length and reciprocating cycles are constant.

$$L_h = \frac{L \times 10^3}{2 \times l_s \times n_1 \times 60}$$

- L_h Service life in hours (hr)
- L Nominal life (km)
- l_s Stroke length (m)
- n_1 No. of reciprocating cycles per minute (min^{-1})

5 Friction Coefficient

A linear guideway manipulates linear motion by rolling elements between the rail and the carriage. In which type of motion, the frictional resistance of linear guideway can be reduced to 1/20th to 1/40th of that in a slide guide. This is especially true in static friction which is much smaller than that in other systems. Moreover, the difference between static and dynamic friction is very little, so that the stick-slip situation does not occur. As such low friction, the submicron feeding can be carried out. The frictional resistance of a linear guideway system can be varied with the magnitude of load and preload, the viscosity resistance of lubricant, and other factors. The frictional resistance can be calculated by the following equation base on working load and seals resistance. Generally, the friction coefficient will be different from series to series, the friction coefficient of ball type is 0.002~0.003 (without considering the seal resistance) and the roller type is 0.001~0.002(without considering the seal resistance)

$$F = \mu \times P + f$$

- F Frictional resistance (kgf)
- μ Dynamic friction coefficient
- P Working load (kgf)
- f Seal resistance (kgf)

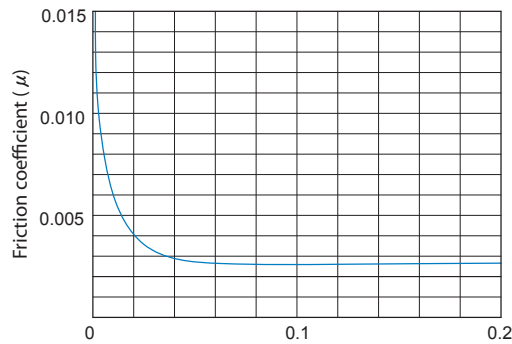

Load ratio (P/C)
 P: Working load
 C: Basic dynamic load rating

Relationship between working load and friction coefficient

6 Calculation of Working Load

The load applied to a linear guideway system could be varied with several factors such as the location of the center gravity of an object, the location of the thrust, and the inertial forces due to acceleration and deceleration during starting and stopping.

To select a correct linear guideway system, the above conditions must be considered for determining the magnitude of applied load.

Examples for calculating working load

Type	Horizontal application: Uniform motion or at rest
Operation Conditions	
Equations	$P_1 = \frac{F}{4} + \frac{F \cdot l_3}{2 \cdot l_1} - \frac{F \cdot l_4}{2 \cdot l_2}$ $P_2 = \frac{F}{4} - \frac{F \cdot l_3}{2 \cdot l_1} - \frac{F \cdot l_4}{2 \cdot l_2}$ $P_3 = \frac{F}{4} - \frac{F \cdot l_3}{2 \cdot l_1} + \frac{F \cdot l_4}{2 \cdot l_2}$ $P_4 = \frac{F}{4} + \frac{F \cdot l_3}{2 \cdot l_1} + \frac{F \cdot l_4}{2 \cdot l_2}$

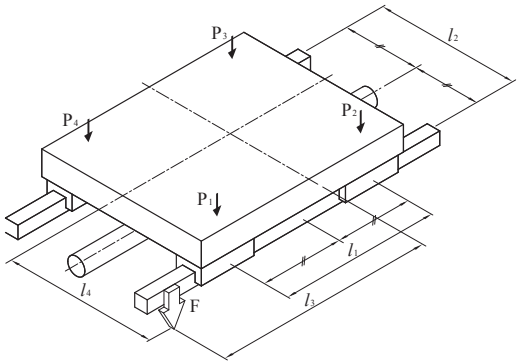
Type	<p>Overhung horizontal application: Uniform motion or at rest</p>
Operation Conditions	
Equations	$P_1 = \frac{F}{4} + \frac{F \cdot l_3}{2 \cdot l_1} + \frac{F \cdot l_4}{2 \cdot l_2}$ $P_2 = \frac{F}{4} - \frac{F \cdot l_3}{2 \cdot l_1} + \frac{F \cdot l_4}{2 \cdot l_2}$ $P_3 = \frac{F}{4} - \frac{F \cdot l_3}{2 \cdot l_1} - \frac{F \cdot l_4}{2 \cdot l_2}$ $P_4 = \frac{F}{4} + \frac{F \cdot l_3}{2 \cdot l_1} - \frac{F \cdot l_4}{2 \cdot l_2}$

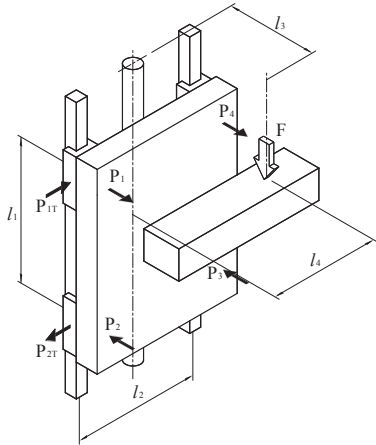
Type	<p>Vertical application: Uniform motion or at rest</p>
Operation Conditions	
Equations	$P_1 = P_2 = P_3 = P_4 = \frac{F \cdot l_3}{2 \cdot l_1}$ $P_{1T} = P_{2T} = P_{3T} = P_{4T} = \frac{F \cdot l_4}{2 \cdot l_1}$

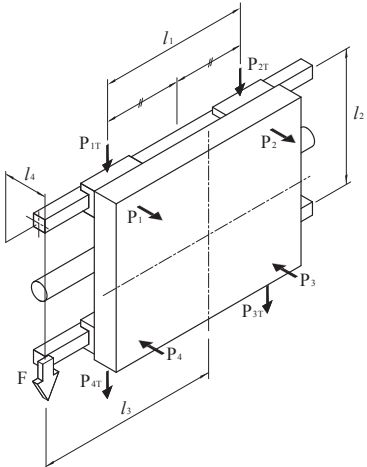
<p>Type</p>	<p>Wall installation application: Uniform motion or at rest</p>
<p>Operation Conditions</p>	
<p>Equations</p>	$P_1 = P_2 = P_3 = P_4 = \frac{F \cdot l_4}{2 \cdot l_2}$ $P_{1r} = P_{4r} = \frac{F}{4} + \frac{F \cdot l_3}{2 \cdot l_1}$ $P_{2r} = P_{3r} = \frac{F}{4} - \frac{F \cdot l_3}{2 \cdot l_1}$

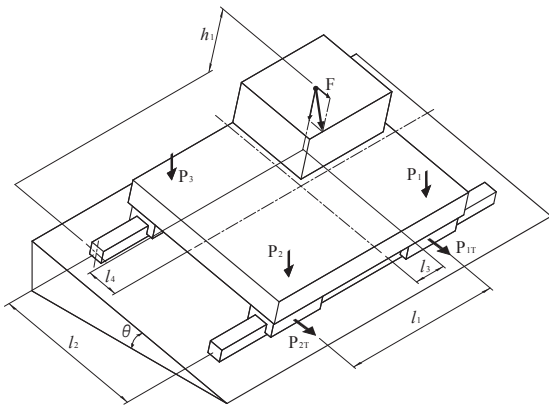
<p>Type</p>	<p>Laterally tilted application</p>
<p>Operation Conditions</p>	
<p>Equations</p>	$P_1 = \frac{F \cdot \cos\theta}{4} + \frac{F \cdot \cos\theta \cdot l_3}{2 \cdot l_1} - \frac{F \cdot \cos\theta \cdot l_4}{2 \cdot l_2} + \frac{F \cdot \sin\theta \cdot h_1}{2 \cdot l_2}$ $P_2 = \frac{F \cdot \cos\theta}{4} - \frac{F \cdot \cos\theta \cdot l_3}{2 \cdot l_1} - \frac{F \cdot \cos\theta \cdot l_4}{2 \cdot l_2} + \frac{F \cdot \sin\theta \cdot h_1}{2 \cdot l_2}$ $P_3 = \frac{F \cdot \cos\theta}{4} - \frac{F \cdot \cos\theta \cdot l_3}{2 \cdot l_1} + \frac{F \cdot \cos\theta \cdot l_4}{2 \cdot l_2} - \frac{F \cdot \sin\theta \cdot h_1}{2 \cdot l_2}$ $P_4 = \frac{F \cdot \cos\theta}{4} + \frac{F \cdot \cos\theta \cdot l_3}{2 \cdot l_1} + \frac{F \cdot \cos\theta \cdot l_4}{2 \cdot l_2} - \frac{F \cdot \sin\theta \cdot h_1}{2 \cdot l_2}$ $P_{1r} = P_{4r} = \frac{F \cdot \sin\theta}{4} + \frac{F \cdot \sin\theta \cdot l_3}{2 \cdot l_1}$ $P_{2r} = P_{3r} = \frac{F \cdot \sin\theta}{4} - \frac{F \cdot \sin\theta \cdot l_3}{2 \cdot l_1}$

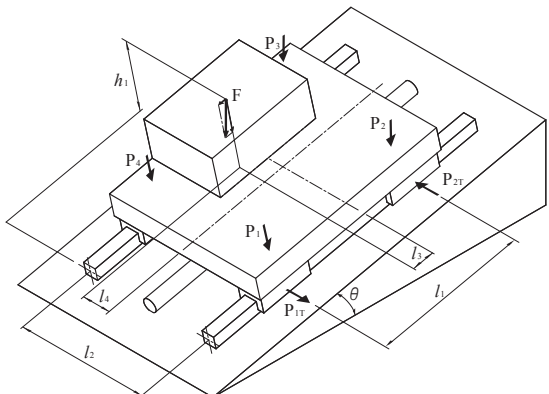
<p>Type</p>	<p>Longitudinally tilted application</p>
<p>Operation Conditions</p>	
<p>Equations</p>	$P_1 = \frac{F \cdot \cos\theta}{4} + \frac{F \cdot \cos\theta \cdot l_3}{2 \cdot l_1} - \frac{F \cdot \cos\theta \cdot l_4}{2 \cdot l_2} + \frac{F \cdot \sin\theta \cdot h_1}{2 \cdot l_1}$ $P_2 = \frac{F \cdot \cos\theta}{4} - \frac{F \cdot \cos\theta \cdot l_3}{2 \cdot l_1} - \frac{F \cdot \cos\theta \cdot l_4}{2 \cdot l_2} - \frac{F \cdot \sin\theta \cdot h_1}{2 \cdot l_1}$ $P_3 = \frac{F \cdot \cos\theta}{4} - \frac{F \cdot \cos\theta \cdot l_3}{2 \cdot l_1} + \frac{F \cdot \cos\theta \cdot l_4}{2 \cdot l_2} - \frac{F \cdot \sin\theta \cdot h_1}{2 \cdot l_1}$ $P_4 = \frac{F \cdot \cos\theta}{4} + \frac{F \cdot \cos\theta \cdot l_3}{2 \cdot l_1} + \frac{F \cdot \cos\theta \cdot l_4}{2 \cdot l_2} + \frac{F \cdot \sin\theta \cdot h_1}{2 \cdot l_1}$ $P_{1r} = P_{4r} = + \frac{F \cdot \sin\theta \cdot l_4}{2 \cdot l_1}$ $P_{2r} = P_{3r} = - \frac{F \cdot \sin\theta \cdot l_4}{2 \cdot l_1}$

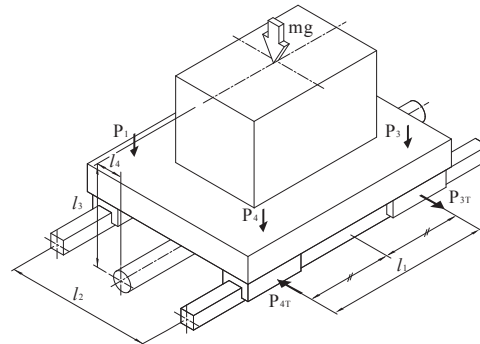
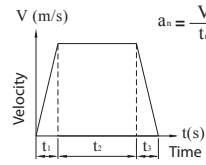
<p>Type</p>	<p>Horizontal application: Subjected to inertia</p>	
<p>Operation Conditions</p>		 <p>Velocity diagram</p>
<p>Equations</p>	<p>During acceleration</p> $P_1 = P_4 = \frac{mg}{4} - \frac{m \cdot a_i \cdot l_3}{2 \cdot l_1}$ $P_2 = P_3 = \frac{mg}{4} + \frac{m \cdot a_i \cdot l_3}{2 \cdot l_1}$ $P_{1r} = P_{2r} = P_{3r} = P_{4r} = \frac{m \cdot a_i \cdot l_4}{2 \cdot l_1}$ <p>In uniform motion</p> $P_1 = P_2 = P_3 = P_4 = \frac{mg}{4}$	<p>During deceleration</p> $P_1 = P_4 = \frac{mg}{4} + \frac{m \cdot a_i \cdot l_3}{2 \cdot l_1}$ $P_2 = P_3 = \frac{mg}{4} - \frac{m \cdot a_i \cdot l_3}{2 \cdot l_1}$ $P_{1r} = P_{2r} = P_{3r} = P_{4r} = \frac{m \cdot a_i \cdot l_4}{2 \cdot l_1}$

7 Calculation of the Equivalent Load

Type	Vertical application: Subjected to inertia	
Operation Conditions		
Equations	<p>During acceleration</p> $P_i = P_2 = P_3 = P_4 = \frac{m \cdot (g + a_i) \cdot l_3}{2 \cdot l_1}$ $P_{1r} = P_{2r} = P_{3r} = P_{4r} = \frac{m \cdot (g + a_i) \cdot l_4}{2 \cdot l_1}$ <p>In uniform motion</p> $P_i = P_2 = P_3 = P_4 = \frac{m \cdot g \cdot l_3}{2 \cdot l_1}$ $P_{1r} = P_{2r} = P_{3r} = P_{4r} = \frac{m \cdot g \cdot l_4}{2 \cdot l_1}$	<p>During deceleration</p> $P_i = P_2 = P_3 = P_4 = \frac{m \cdot (g - a_d) \cdot l_3}{2 \cdot l_1}$ $P_{1r} = P_{2r} = P_{3r} = P_{4r} = \frac{m \cdot (g - a_d) \cdot l_4}{2 \cdot l_1}$

The linear guideway system can take up loads and moments in all four directions those are radial load, reverse-radial load, and lateral load simultaneously. When more than one load is exerted on linear guideway system simultaneously, all loads could be converted into radial or lateral equivalent load for calculating service life and static safety factor. **PMI** linear guideway has four-way equal load design. The calculation of equivalent load for the use of two or more linear guideways is shown as below.

$$P_E = |P_R| + |P_T|$$

- P_E Equivalent load (N)
- P_R Radial or reverse-radial load (N)
- P_T Lateral load (N)

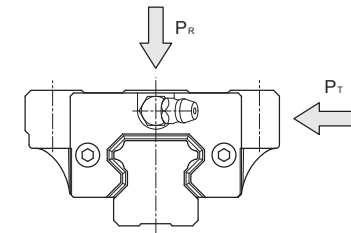

For the case of mono rail, the moment effect should be considered. The equation is:

$$P_E = |P_R| + |P_T| + C_0 \cdot \frac{|M|}{M_R}$$

- P_E Equivalent load (N)
- P_R Radial or reverse-radial load (N)
- P_T Lateral load (N)
- C_0 Basic static load rating (N)
- M Calculated moment (N · m)
- M_R Permissible static moment (N · m)

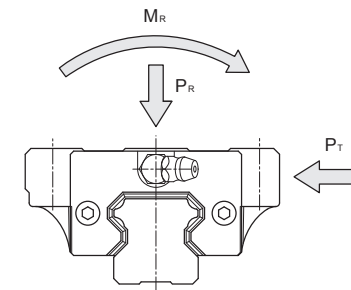

When a linear guideway system receives varying loads, the service life could be calculated in consideration of varying loads of the host-system operation conditions. The mean load (P_m) is the load that the service life is equivalent to the system which under the varying load conditions. The equation of mean load is:

$$P_m = e \sqrt{\frac{1}{L} \cdot \sum_{n=1}^n (P_n^e \cdot L_n)}$$

- P_m Mean load (N)
- P_n Varying load (N)
- L Total running distance (mm)
- L_n Running distance under load P_n (mm)
- e Exponent (Ball type:3, Roller type:10/3)

Examples for calculating mean load

Types of Varying Load	Calculation of Mean Load
-----------------------	--------------------------

Loads that change stepwise

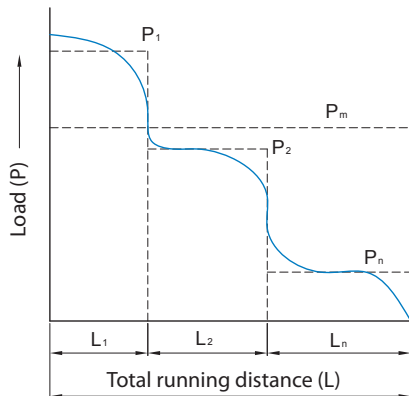

$$P_m = e \sqrt{\frac{1}{L} (P_1^e \cdot L_1 + P_2^e \cdot L_2 + \dots + P_n^e \cdot L_n)}$$

- P_m Mean load (N)
- P_n Varying load (N)
- L Total running distance (mm)
- L_n Running distance under load P_n (mm)

Types of Varying Load	Calculation of Mean Load
-----------------------	--------------------------

Loads that change monotonously

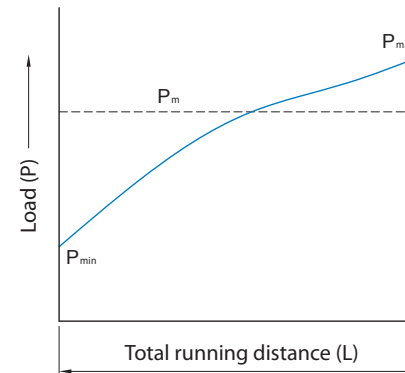

$$P_m \cong \frac{1}{3} (P_{min} + 2 \cdot P_{max})$$

- P_m Mean load (N)
- P_{min} Minimum load (N)
- P_{max} Maximum load (N)

Loads that change sinusoidally

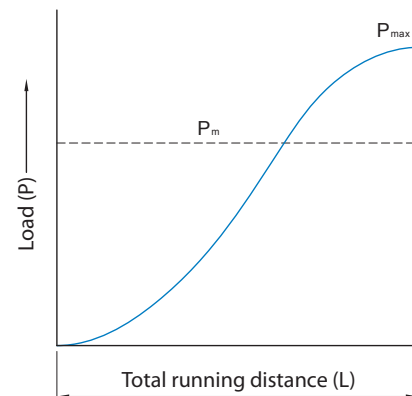

$$P_m \cong 0.65 \cdot P_{max}$$

Mean load (N)
Maximum load (N)

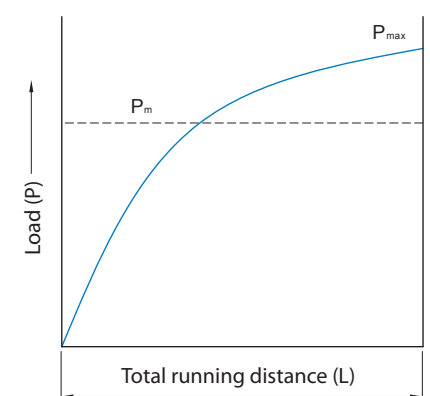

$$P_m \cong 0.75 \cdot P_{max}$$

Mean load (N)
Maximum load (N)

9 Calculation Example

Operation conditions

Modle MSA35LA2SSFC + R2520-20/20 P II

Basic dynamic load rating : C = 63.6 kN

Basic static load rating : C₀ = 100.6 kN

Mass	m ₁ = 700 kg m ₂ = 450 kg	Stroke	l _s = 1500 mm
Velocity	V = 0.75 m/s	Distance	l ₁ = 650 mm l ₂ = 450 mm l ₃ = 135 mm l ₄ = 60 mm l ₅ = 175 mm l ₆ = 400 mm
Time	t ₁ = 0.05 s t ₂ = 1.9 s t ₃ = 0.15 s		
Acceleration	a ₁ = 15 m/s ² a ₃ = 5 m/s ²		

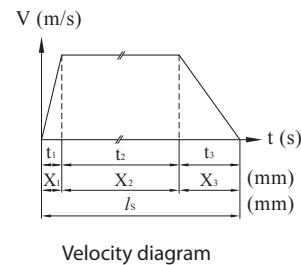
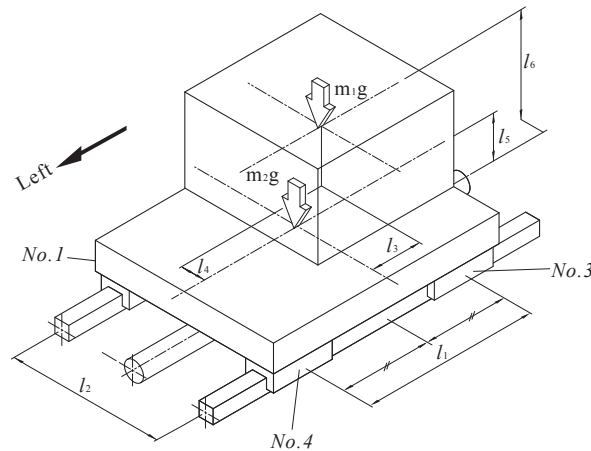

9.1 Calculate the load that each carriage exerts

9.1.1 Uniform motion, Radial load P_n

$$P_1 = \frac{m_1 g}{4} - \frac{m_1 g \cdot l_3}{2l_1} + \frac{m_1 g \cdot l_4}{2l_2} + \frac{m_2 g}{4}$$

$$= 2562.4 \text{ N}$$

$$P_2 = \frac{m_1 g}{4} + \frac{m_1 g \cdot l_3}{2l_1} + \frac{m_1 g \cdot l_4}{2l_2} + \frac{m_2 g}{4}$$

$$= 3987.2 \text{ N}$$

$$P_3 = \frac{m_1 g}{4} + \frac{m_1 g \cdot l_3}{2l_1} - \frac{m_1 g \cdot l_4}{2l_2} + \frac{m_2 g}{4}$$

$$= 3072.6 \text{ N}$$

$$P_4 = \frac{m_1 g}{4} - \frac{m_1 g \cdot l_3}{2l_1} - \frac{m_1 g \cdot l_4}{2l_2} + \frac{m_2 g}{4}$$

$$= 1647.8 \text{ N}$$

9.1.2 During acceleration to the left, Radial load P_nl_{a1}

$$P_1 l_{a1} = P_1 - \frac{m_1 \cdot a_1 \cdot l_6}{2l_1} - \frac{m_2 \cdot a_1 \cdot l_5}{2l_1}$$

$$= -1577 \text{ N}$$

$$P_2 l_{a1} = P_2 + \frac{m_1 \cdot a_1 \cdot l_6}{2l_1} + \frac{m_2 \cdot a_1 \cdot l_5}{2l_1}$$

$$= 8126.6 \text{ N}$$

$$P_3 l_{a1} = P_3 + \frac{m_1 \cdot a_1 \cdot l_6}{2l_1} + \frac{m_2 \cdot a_1 \cdot l_5}{2l_1}$$

$$= 7212 \text{ N}$$

$$P_4 l_{a1} = P_4 - \frac{m_1 \cdot a_1 \cdot l_6}{2l_1} - \frac{m_2 \cdot a_1 \cdot l_5}{2l_1}$$

$$= -2491.6 \text{ N}$$

Lateral load P_tl_{a1}

$$P_{t1} l_{a1} = -\frac{m_1 \cdot a_1 \cdot l_4}{2l_1} = -484.6 \text{ N}$$

$$P_{t3} l_{a1} = \frac{m_1 \cdot a_1 \cdot l_4}{2l_1} = 484.6 \text{ N}$$

$$P_{t2} l_{a1} = \frac{m_1 \cdot a_1 \cdot l_4}{2l_1} = 484.6 \text{ N}$$

$$P_{t4} l_{a1} = -\frac{m_1 \cdot a_1 \cdot l_4}{2l_1} = -484.6 \text{ N}$$

9.1.3 During deceleration to the left, Radial load $P_n l a_3$

$$P_1 l a_3 = P_1 + \frac{m_1 \cdot a_3 \cdot l_6}{2l_1} + \frac{m_2 \cdot a_3 \cdot l_5}{2l_1}$$

$$= 3942.2 \text{ N}$$

$$P_2 l a_3 = P_2 - \frac{m_1 \cdot a_3 \cdot l_6}{2l_1} - \frac{m_2 \cdot a_3 \cdot l_5}{2l_1}$$

$$= 2607.4 \text{ N}$$

Lateral load $P_{t_n} l a_3$

$$P_{t_1} l a_3 = \frac{m_1 \cdot a_3 \cdot l_4}{2l_1} = 161.5 \text{ N}$$

$$P_{t_2} l a_3 = -\frac{m_1 \cdot a_3 \cdot l_4}{2l_1} = -161.5 \text{ N}$$

$$P_3 l a_3 = P_3 - \frac{m_1 \cdot a_3 \cdot l_6}{2l_1} - \frac{m_2 \cdot a_3 \cdot l_5}{2l_1}$$

$$= 1692.8 \text{ N}$$

$$P_4 l a_3 = P_4 + \frac{m_1 \cdot a_3 \cdot l_6}{2l_1} + \frac{m_2 \cdot a_3 \cdot l_5}{2l_1}$$

$$= 3027.6 \text{ N}$$

$$P_{t_3} l a_3 = -\frac{m_1 \cdot a_3 \cdot l_4}{2l_1} = 161.5 \text{ N}$$

$$P_{t_4} l a_3 = \frac{m_1 \cdot a_3 \cdot l_4}{2l_1} = -161.5 \text{ N}$$

9.1.4 During acceleration to the right, Radial load $P_n r a_1$

$$P_1 r a_1 = P_1 + \frac{m_1 \cdot a_1 \cdot l_6}{2l_1} + \frac{m_2 \cdot a_1 \cdot l_5}{2l_1}$$

$$= 6701.8 \text{ N}$$

$$P_2 r a_1 = P_2 - \frac{m_1 \cdot a_1 \cdot l_6}{2l_1} - \frac{m_2 \cdot a_1 \cdot l_5}{2l_1}$$

$$= -152.2 \text{ N}$$

Lateral load $P_{t_n} r a_1$

$$P_{t_1} r a_1 = \frac{m_1 \cdot a_1 \cdot l_4}{2l_1} = 484.6 \text{ N}$$

$$P_{t_2} r a_1 = -\frac{m_1 \cdot a_1 \cdot l_4}{2l_1} = -484.6 \text{ N}$$

$$P_3 r a_1 = P_3 - \frac{m_1 \cdot a_1 \cdot l_6}{2l_1} - \frac{m_2 \cdot a_1 \cdot l_5}{2l_1}$$

$$= -1066.8 \text{ N}$$

$$P_4 r a_1 = P_4 + \frac{m_1 \cdot a_1 \cdot l_6}{2l_1} + \frac{m_2 \cdot a_1 \cdot l_5}{2l_1}$$

$$= 5787.2 \text{ N}$$

$$P_{t_3} r a_1 = -\frac{m_1 \cdot a_1 \cdot l_4}{2l_1} = -484.6 \text{ N}$$

$$P_{t_4} r a_1 = \frac{m_1 \cdot a_1 \cdot l_4}{2l_1} = 484.6 \text{ N}$$

9.1.5 During deceleration to the right, Radial load $P_n r a_3$

$$P_1 r a_3 = P_1 - \frac{m_1 \cdot a_3 \cdot l_6}{2l_1} - \frac{m_2 \cdot a_3 \cdot l_5}{2l_1}$$

$$= 1182.6 \text{ N}$$

$$P_2 r a_3 = P_2 + \frac{m_1 \cdot a_3 \cdot l_6}{2l_1} + \frac{m_2 \cdot a_3 \cdot l_5}{2l_1}$$

$$= 5367 \text{ N}$$

Lateral load $P_{t_n} r a_3$

$$P_{t_1} r a_3 = -\frac{m_1 \cdot a_3 \cdot l_4}{2l_1} = -161.5 \text{ N}$$

$$P_{t_2} r a_3 = \frac{m_1 \cdot a_3 \cdot l_4}{2l_1} = 161.5 \text{ N}$$

$$P_3 r a_3 = P_3 + \frac{m_1 \cdot a_3 \cdot l_6}{2l_1} + \frac{m_2 \cdot a_3 \cdot l_5}{2l_1}$$

$$= 4452.4 \text{ N}$$

$$P_4 r a_3 = P_4 - \frac{m_1 \cdot a_3 \cdot l_6}{2l_1} - \frac{m_2 \cdot a_3 \cdot l_5}{2l_1}$$

$$= 268 \text{ N}$$

$$P_{t_3} r a_3 = \frac{m_1 \cdot a_3 \cdot l_4}{2l_1} = 161.5 \text{ N}$$

$$P_{t_4} r a_3 = -\frac{m_1 \cdot a_3 \cdot l_4}{2l_1} = -161.5 \text{ N}$$

9.2 Calculate equivalent load

9.2.1 In uniform motion

$$P_{E1} = P_1 = 2562.4 \text{ N} \quad P_{E3} = P_3 = 3072.6 \text{ N}$$

$$P_{E2} = P_2 = 3987.2 \text{ N} \quad P_{E4} = P_4 = 1647.8 \text{ N}$$

9.2.2 During acceleration to the left

$$P_{E1}la_1 = |P_1la_1| + |Pt_1la_1| = 2061.6 \text{ N} \quad P_{E3}la_1 = |P_3la_1| + |Pt_3la_1| = 7696.6 \text{ N}$$

$$P_{E2}la_1 = |P_2la_1| + |Pt_2la_1| = 8611.2 \text{ N} \quad P_{E4}la_1 = |P_4la_1| + |Pt_4la_1| = 2976.2 \text{ N}$$

9.2.3 During deceleration to the left

$$P_{E1}la_3 = |P_1la_3| + |Pt_1la_3| = 4103.7 \text{ N} \quad P_{E3}la_3 = |P_3la_3| + |Pt_3la_3| = 1854.3 \text{ N}$$

$$P_{E2}la_3 = |P_2la_3| + |Pt_2la_3| = 2768.9 \text{ N} \quad P_{E4}la_3 = |P_4la_3| + |Pt_4la_3| = 3189.1 \text{ N}$$

9.2.4 During acceleration to the right

$$P_{E1}ra_1 = |P_1ra_1| + |Pt_1ra_1| = 7186.4 \text{ N} \quad P_{E3}ra_1 = |P_3ra_1| + |Pt_3ra_1| = 1551.4 \text{ N}$$

$$P_{E2}ra_1 = |P_2ra_1| + |Pt_2ra_1| = 636.8 \text{ N} \quad P_{E4}ra_1 = |P_4ra_1| + |Pt_4ra_1| = 6271.8 \text{ N}$$

9.2.5 During deceleration to the right

$$P_{E1}ra_3 = |P_1ra_3| + |Pt_1ra_3| = 1344.1 \text{ N} \quad P_{E3}ra_3 = |P_3ra_3| + |Pt_3ra_3| = 4613.9 \text{ N}$$

$$P_{E2}ra_3 = |P_2ra_3| + |Pt_2ra_3| = 5528.5 \text{ N} \quad P_{E4}ra_3 = |P_4ra_3| + |Pt_4ra_3| = 429.5 \text{ N}$$

9.3 Calculation of static factor

From above, the maximum load is exerted on carriage No.2 when during acceleration of the 2nd linear guideway to the left.

$$f_s = \frac{C_o}{P_{E2}la_1} = \frac{100.6 \times 10^3}{8611.2} = 11.7$$

9.4 Calculate the mean load on each carriage Pm_n

$$P_{m1} = \sqrt[3]{\frac{(P_{E1}la_1^3 \cdot X_1 + P_{E1}^3 \cdot X_2 + P_{E1}la_3^3 \cdot X_3 + P_{E1}ra_1^3 \cdot X_1 + P_{E1}^3 \cdot X_2 + P_{E1}ra_3^3 \cdot X_3)}{2l_s}} = 2700.7 \text{ N}$$

$$P_{m2} = \sqrt[3]{\frac{(P_{E2}la_1^3 \cdot X_1 + P_{E2}^3 \cdot X_2 + P_{E2}la_3^3 \cdot X_3 + P_{E2}ra_1^3 \cdot X_1 + P_{E2}^3 \cdot X_2 + P_{E2}ra_3^3 \cdot X_3)}{2l_s}} = 4077.2 \text{ N}$$

$$P_{m3} = \sqrt[3]{\frac{(P_{E3}la_1^3 \cdot X_1 + P_{E3}^3 \cdot X_2 + P_{E3}la_3^3 \cdot X_3 + P_{E3}ra_1^3 \cdot X_1 + P_{E3}^3 \cdot X_2 + P_{E3}ra_3^3 \cdot X_3)}{2l_s}} = 3187.7 \text{ N}$$

$$P_{m4} = \sqrt[3]{\frac{(P_{E4}la_1^3 \cdot X_1 + P_{E4}^3 \cdot X_2 + P_{E4}la_3^3 \cdot X_3 + P_{E4}ra_1^3 \cdot X_1 + P_{E4}^3 \cdot X_2 + P_{E4}ra_3^3 \cdot X_3)}{2l_s}} = 1872.6 \text{ N}$$

9.5 Calculation of nominal life (L_n)

Base on the equation of the nominal life, we assume the $f_w=1.5$ and the result is as below:

$$L_1 = \left(\frac{C}{f_w \cdot P_{m1}} \right)^3 \times 50 = 193500 \text{ km} \quad L_3 = \left(\frac{C}{f_w \cdot P_{m3}} \right)^3 \times 50 = 117700 \text{ km}$$

$$L_2 = \left(\frac{C}{f_w \cdot P_{m2}} \right)^3 \times 50 = 56231 \text{ km} \quad L_4 = \left(\frac{C}{f_w \cdot P_{m4}} \right)^3 \times 50 = 580400 \text{ km}$$

From these calculations and under the operating conditions specified as above, the 56231 km running distance as service life of carriage No.2 is obtained.

10 Accuracy Standard

The accuracy of linear guideway includes the dimensional tolerance of height, width, and the running accuracy of the carriage on the rail. The standard of the dimension difference is built for two or more carriages on a rail or a number of rails are used on the same plane. The accuracy of linear guideway is divided into 5 classes, normal grade (N), high precision (H), precision (P), super precision (SP), and ultra precision (UP).

Running parallelism

The running accuracy is the deviation of parallelism between the reference surface of carriage and reference surface of rail when carriage moving over the entire length of rail.

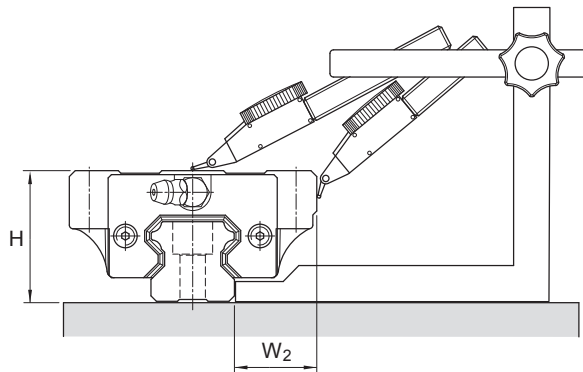

Height difference (ΔH)

The height difference (ΔH) means the height difference among carriages installed on the same plane.

Width difference (ΔW_2)

The width difference (ΔW_2) means the width difference among carriages installed on a rail.

Additional remarks :

1. When two or more linear guideways are used on the same plane, the tolerance of W_2 and difference of ΔW_2 is applicable to master rail only.
2. The accuracy is measured at the center or central area of carriage.

10.1 The Selection of Accuracy Grade

The accuracy grade for different applications shown as table below.

Sort	Application	Accuracy Grade				
		N	H	P	SP	UP
Machine Tool	Machining center			•	•	
	Lathe			•	•	
	Milling machine			•	•	
	Boring machine			•	•	
	Jig borer				•	•
	Grinding machine				•	•
	Electric discharge machine			•	•	•
	Punching press		•	•		
	Laser-beam machine		•	•	•	
	Woodworking machine	•	•	•		
	NC drilling machine		•	•		
	Tapping center		•	•		
	Pallet changer	•				
	ATC	•				
	Wire cutter			•	•	
Dresser				•	•	

Sort	Application	Accuracy Grade				
		N	H	P	SP	UP
Industrial Robot	Cartesian coordinate robot	•	•	•		
	Cylindrical coordinate robot	•	•			
Semiconductor Manufacturing	Wire bonder			•	•	
	Prober				•	•
	Electronic-component inserter		•	•		
	Printed-circuit-board drilling machine		•	•	•	
Others	Injection-molding machine	•	•			
	3D measuring instrument				•	•
	Office equipment	•	•			
	Transfer equipment	•	•			
	XY table		•	•	•	
	Painting machine	•	•			
	Welding machine	•	•			
	Medical equipment	•	•			
	Digitizer		•	•	•	
	Inspection equipment			•	•	•

The rigidity of a linear guideway could be enhanced by increasing the preload. As shown as below figure, the load could be raised up to 2.8 times the preload applied. The preload is represented by negative clearance resulting from the increase of rolling element diameter. Therefore, the preload should be considered in calculation service life.

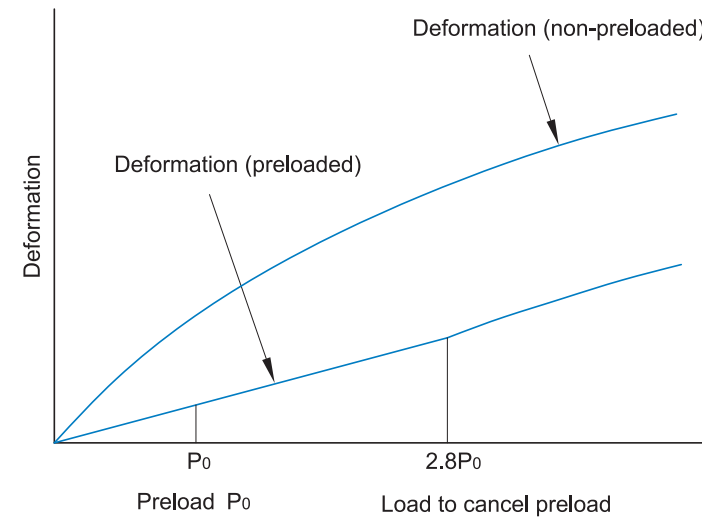

11.1 The Selection of Preload

Selecting proper preload from table below to adapt the specific application and condition.

Preload grade	Fitted condition	Application examples
Clearance (FZ)	<ul style="list-style-type: none"> The loading direction is fixed, vibration and impact are light, and two axes are applied in parallel. High precision is not required, and the low frictional resistance is needed. 	Semiconductor facilities, medical equipment, stage systems, press machine, welding machine, industrial robot, and other small sliding systems.
Light preload (FC)	<ul style="list-style-type: none"> The loading direction is fixed, vibration and impact are light, and two axes are applied in parallel. High precision is not required, and the low frictional resistance is needed. 	Welding machine, binding machine, auto packing machine, XY axis of ordinary industrial machine, material handling equipments.
Medium preload (F0)	<ul style="list-style-type: none"> Overhang application with a moment load. Applied in one-axis configuration The need of light preload and high precision. 	Z axis of industrial machines, EDM, precision XY table, PC board drilling machine, industrial robot, NC lathe, measuring equipment, grinding machine, auto painting machine.
Heavy preload (F1)	<ul style="list-style-type: none"> Machine is subjected to vibration and impact, and high rigidity required. Application of heavy load or heavy cutting. 	Machine center, NC lathe, grinding machine, milling machine, Z axis of boring machine and machine tools.
Ultra heavy preload (F2)	<ul style="list-style-type: none"> Machine is subjected to vibration and impact, and high rigidity required. Application of heavy load or heavy cutting. 	Machine center, NC lathe, grinding machine, milling machine, Z axis of boring machine and machine tools.

12.1 Heavy Load Type, MSA Series

A. Construction

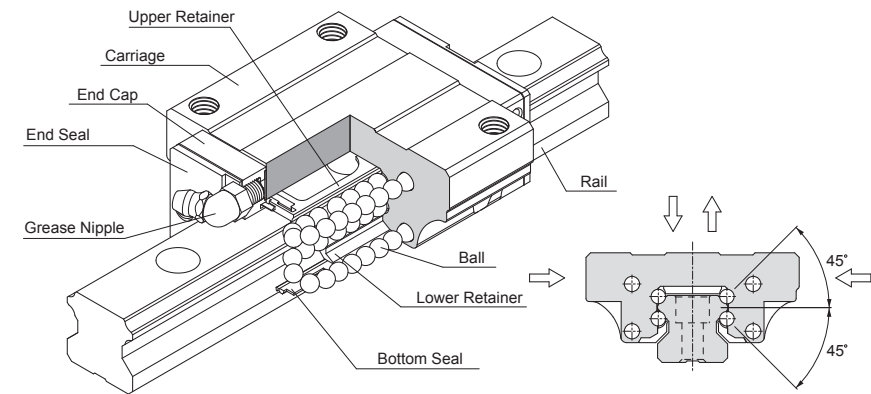

B. Characteristics

The trains of balls are designed to a contact angle of 45° which enables it to bear an equal load in radial, reversed radial and lateral directions. Therefore, it can be applied in any installation direction. Furthermore, MSA series can achieve a well balanced preload for increasing rigidity in four directions while keeping a low frictional resistance. This is especially suit to high precision and high rigidity required motion.

The patent design of lubrication route makes the lubricant evenly distribute in each circulation loop. Therefore, the optimum lubrication can be achieved in any installation direction, and this promotes the performance in running accuracy, service life, and reliability.

High Rigidity, Four-way Equal Load

The four trains of balls are allocated to a circular contact angle at 45°, thus each train of balls can take up an equal rated load in all four directions. Moreover, a sufficient preload can be achieved to increase rigidity, and this makes it suitable for any kind of installation.

Smooth Movement with Low Noise

The simplified design of circulating system with strengthened synthetic resin accessories makes the movement smooth and quiet.

Self Alignment Capability

The self adjustment is performed spontaneously as the design of face-to-face (DF) circular arc groove. Therefore, the installation error could be compensated even under a preload, and which results in precise and smooth linear motion.

Interchangeability

For interchangeable type of linear guideway, the dimensional tolerances are strictly maintained within a reasonable range, and this has made the random matching of the same size of rails and carriages possible. Therefore, the similar preload and accuracy can be obtained even under the random matching condition. As a result of this advantage, the linear guideway can be stocked as standard parts, the installation and maintenance become more convenient. Moreover, this is also beneficial for shortening the delivery time.

C. Carriage Type

Heavy Load

MSA-A Type

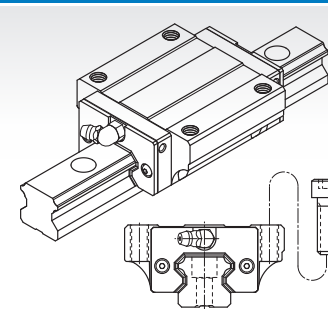

Installed from top side of carriage with the thread length longer than MSA-E type.

MSA-E Type

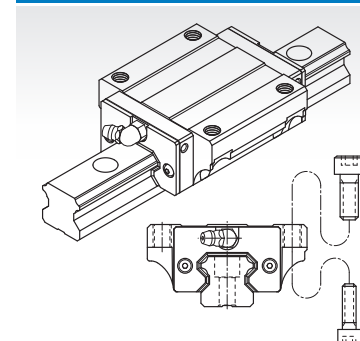

This type offers the installation either from top or bottom side of carriage.

MSA-S Type

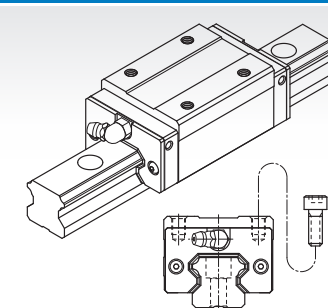

Square type with smaller width and can be installed from top side of carriage.

Ultra Heavy Load

MSA-LA Type

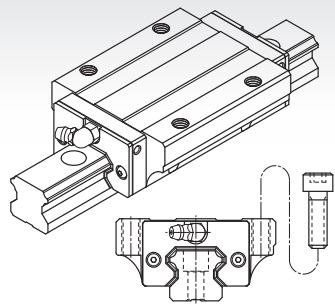

All dimensions are same as MSA-A except the length is longer, which makes it more rigid.

MSA-LE Type

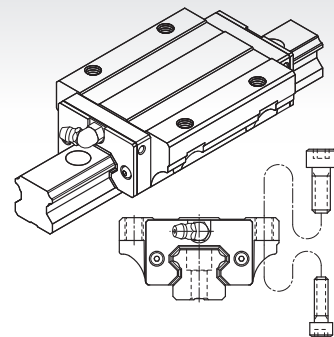

All dimensions are same as MSA-E except the length is longer, which makes it more rigid.

MSA-LS Type

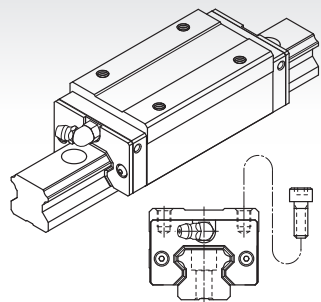

All dimensions are same as MSA-S except the length is longer, which makes it more rigid.

D. Rail Type

Counter bore (R type)

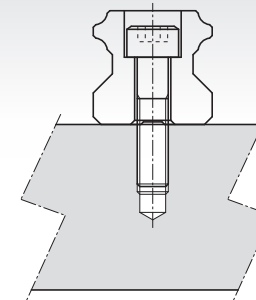

Tapped Hole (T type)

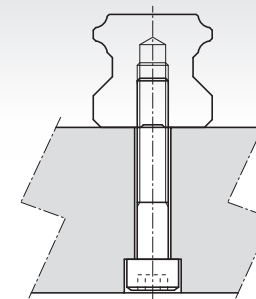

E. Description of Specification

(1) Non-Interchangeable Type

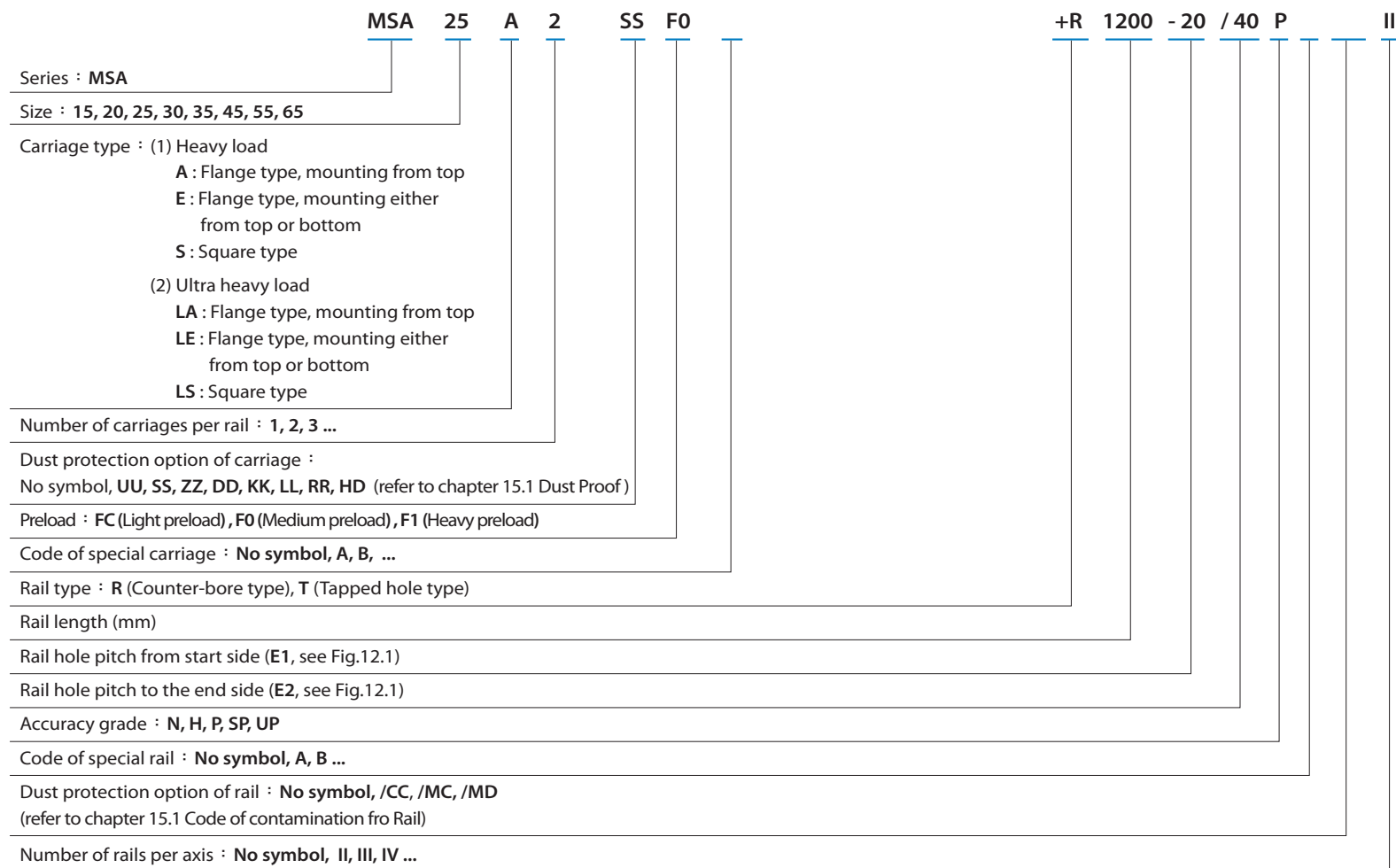

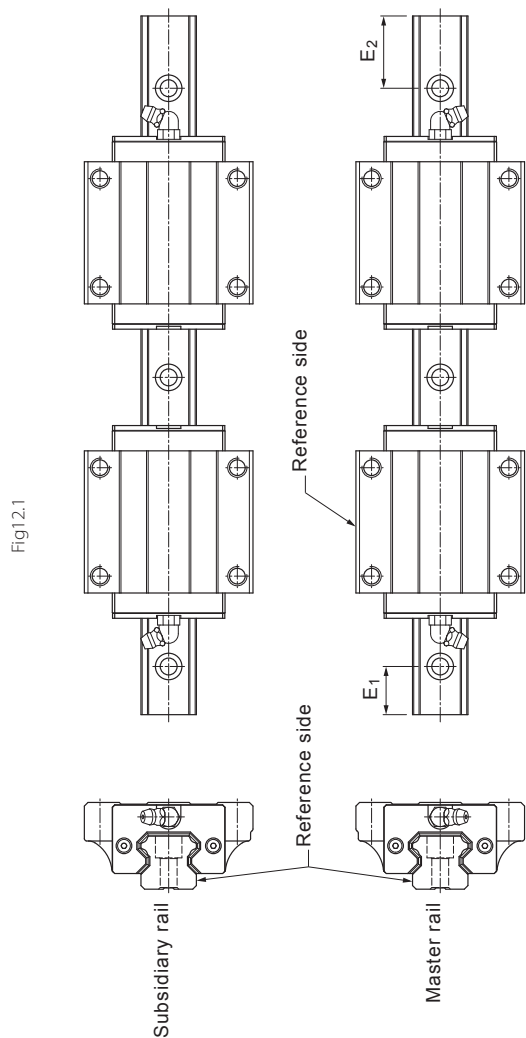

Fig.12.1

(2) Interchangeable Type

Code of Carriage

	MSA	25	A	SS	FC	N
Series : MSA	-----					
Size : 15, 20, 25, 30, 35, 45, 55, 65	-----					
Carriage type : (1) Heavy load	-----					
A : Flange type, mounting from top	-----					
E : Flange type, mounting either from top or bottom	-----					
S : Square type	-----					
(2) Ultra heavy load	-----					
LA : Flange type, mounting from top	-----					
LE : Flange type, mounting either from top or bottom	-----					
LS : Square type	-----					
Dust protection option of carriage : No symbol, UU, SS, ZZ, DD, KK, LL, RR, HD	-----					
(refer to chapter 15.1 Dust Proof)	-----					
Preload : FC (Light preload), F0 (Medium preload)	-----					
Accuracy grade : N, H, P	-----					
Code of special carriage : No symbol, A, B, ...	-----					

Code of Rail

	MSA	25	R	1200	-20	/40	N
Series : MSA	-----						
Size : 15, 20, 25, 30, 35, 45, 55, 65	-----						
Rail type : R (Counter-bore type), T (Tapped hole type)	-----						
Rail length (mm)	-----						
Rail hole pitch from start side (E1, see Fig.12.1)	-----						
Rail hole pitch to the end side (E2, see Fig.12.1)	-----						
Accuracy grade : N, H, P	-----						
Code of special rail : No symbol, A, B ...	-----						
Dust protection option of rail : No symbol, /CC, /MC	-----						
(refer to chapter 15.1 Code of contamination fro Rail)	-----						

F. Accuracy Grade

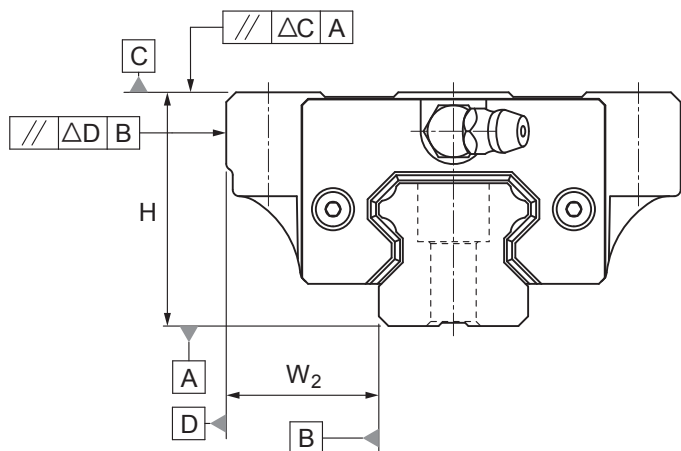

Table 1 Running Parallelism

Rail length (mm)		Running Parallelism Values(μm)				
Above	Or less	N	H	P	SP	UP
0	315	9	6	3	2	1.5
315	400	11	8	4	2	1.5
400	500	13	9	5	2	1.5
500	630	16	11	6	2.5	1.5
630	800	18	12	7	3	2
800	1000	20	14	8	4	2
1000	1250	22	16	10	5	2.5
1250	1600	25	18	11	6	3
1600	2000	28	20	13	7	3.5
2000	2500	30	22	15	8	4
2500	3000	32	24	16	9	4.5
3000	3500	33	25	17	11	5
3500	4000	34	26	18	12	6

A Non-Interchangeable Type

Model No.	Item	Accuracy Grade				
		Normal N	High H	Precision P	Super Precision SP	Ultra Precision UP
15 20	Tolerance for height H	± 0.1	± 0.03	0 -0.03	0 -0.015	0 -0.008
	Height difference ΔH	0.02	0.01	0.006	0.004	0.003
	Tolerance for distance W_2	± 0.1	± 0.03	0 -0.03	0 -0.015	0 -0.008
	Difference in distance $W_2(\Delta W_2)$	0.02	0.01	0.006	0.004	0.003
	Running parallelism of surface C with surface A	ΔC (see the table 1)				
	Running parallelism of surface D with surface B	ΔD (see the table 1)				
25 30 35	Tolerance for height H	± 0.1	± 0.04	0 -0.04	0 -0.02	0 -0.01
	Height difference ΔH	0.02	0.015	0.007	0.005	0.003
	Tolerance for distance W_2	± 0.1	± 0.04	0 -0.04	0 -0.02	0 -0.01
	Difference in distance $W_2(\Delta W_2)$	0.03	0.015	0.007	0.005	0.003
	Running parallelism of surface C with surface A	ΔC (see the table 1)				
	Running parallelism of surface D with surface B	ΔD (see the table 1)				
45 55	Tolerance for height H	± 0.1	± 0.05	0 -0.05	0 -0.03	0 -0.02
	Height difference ΔH	0.03	0.015	0.007	0.005	0.003
	Tolerance for distance W_2	± 0.1	± 0.05	0 -0.05	0 -0.03	0 -0.02
	Difference in distance $W_2(\Delta W_2)$	0.03	0.02	0.01	0.007	0.005
	Running parallelism of surface C with surface A	ΔC (see the table 1)				
	Running parallelism of surface D with surface B	ΔD (see the table 1)				
65	Tolerance for height H	± 0.1	± 0.07	0 -0.07	0 -0.05	0 -0.03
	Height difference ΔH	0.03	0.02	0.01	0.007	0.005
	Tolerance for distance W_2	± 0.1	± 0.07	0 -0.07	0 -0.05	0 -0.03
	Difference in distance $W_2(\Delta W_2)$	0.03	0.025	0.015	0.01	0.007
	Running parallelism of surface C with surface A	ΔC (see the table 1)				
	Running parallelism of surface D with surface B	ΔD (see the table 1)				

B Interchangeable Type

Model No.	Item	Accuracy Grade		
		Normal N	High H	Precision P
15 20	Tolerance for height H	±0.1	±0.03	0 -0.03
	Height difference ΔH	0.02	0.01	0.006
	Tolerance for distance W ₂	±0.1	±0.03	0 -0.03
	Difference in distance W ₂ (ΔW ₂)	0.02	0.01	0.006
	Running parallelism of surface C with surface A	ΔC (see the table 1)		
	Running parallelism of surface D with surface B	ΔD (see the table 1)		
25 30 35	Tolerance for height H	±0.1	±0.04	0 -0.04
	Height difference ΔH	0.02	0.015	0.007
	Tolerance for distance W ₂	±0.1	±0.04	0 -0.04
	Difference in distance W ₂ (ΔW ₂)	0.03	0.015	0.007
	Running parallelism of surface C with surface A	ΔC (see the table 1)		
	Running parallelism of surface D with surface B	ΔD (see the table 1)		
45 55	Tolerance for height H	±0.1	±0.05	0 -0.05
	Height difference ΔH	0.03	0.015	0.007
	Tolerance for distance W ₂	±0.1	±0.05	0 -0.05
	Difference in distance W ₂ (ΔW ₂)	0.03	0.02	0.01
	Running parallelism of surface C with surface A	ΔC (see the table 1)		
	Running parallelism of surface D with surface B	ΔD (see the table 1)		
65	Tolerance for height H	±0.1	±0.07	0 -0.07
	Height difference ΔH	0.03	0.02	0.01
	Tolerance for distance W ₂	±0.1	±0.07	0 -0.07
	Difference in distance W ₂ (ΔW ₂)	0.03	0.025	0.015
	Running parallelism of surface C with surface A	ΔC (see the table 1)		
	Running parallelism of surface D with surface B	ΔD (see the table 1)		

G. Preload Grade

Series	Preload grade		
	Light preload (FC)	Medium preload (F0)	Heavy preload (F1)
MSA15	0~0.02C	0.03~0.05C	-
MSA20			
MSA25			
MSA30			
MSA35			
MSA45			
MSA65			
MSA20L	0~0.02C	0.03~0.05C	0.05~0.08C
MSA25L			
MSA30L			
MSA35L			
MSA45L			
MSA55L			
MSA65L			

Note: C is basic dynamic load rating in above table. Refer to the specification of products, please.

H. The Shoulder Height and Corner Radius for Installation

MSA series

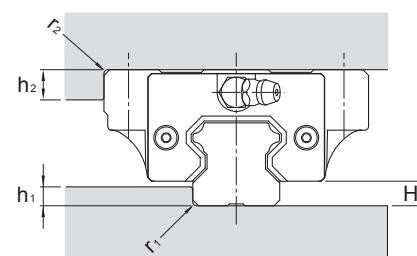

Unit: mm

Model No.	r ₁ (max.)	r ₂ (max.)	h ₁	h ₂	H ₂
15	0.5	0.5	3	4	4.2
20	0.5	0.5	3.5	5	5
25	1	1	5	5	6.5
30	1	1	5	5	8
35	1	1	6	6	9.5
45	1	1	8	8	10
55	1.5	1.5	10	10	13
65	1.5	1.5	10	10	15

I. Dimensional Tolerance of Mounting Surface

MSA Series

With the self alignment capability, the minor dimensional error in mounting surface could be compensated and achieves smooth linear motion. The tolerances of parallelism between two axes are shown as below.

The parallel deviation between two axes (e_1)

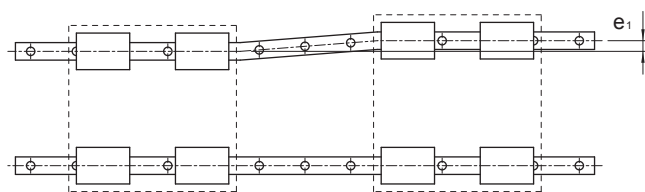

Unit: μm

Model No.	Preload Grade		
	FC	F0	F1
15	25	18	-
20	25	20	18
25	30	22	20
30	40	30	27
35	50	35	30
45	60	40	35
55	70	50	45
65	80	60	55

Level difference between two axes (e_2)

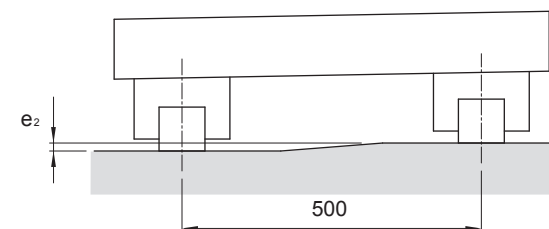

Unit: μm

Model No.	Preload Grade		
	FC	F0	F1
15	130	85	-
20	130	85	50
25	130	85	70
30	170	110	90
35	210	150	120
45	250	170	140
55	300	210	170
65	350	250	200

Note: The permissible values in table are applicable when the span is 500mm wide.

J. Rail Maximum Length and Standrad

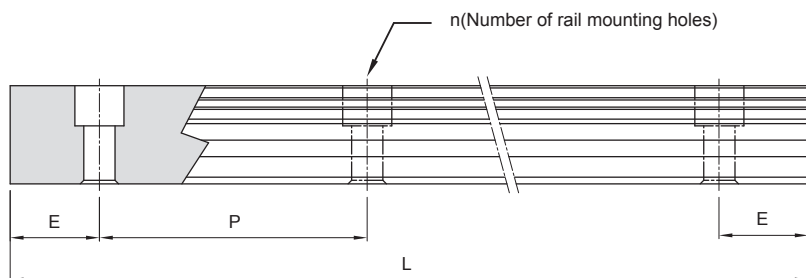

$$L = (n-1) \times P + 2 \times E$$

L: Total Length of rail (mm)

n: Nuber of mounting holes

P: Distance between any two holes (mm)

E: Distance from the center of the last hole to the edge (mm)

Unit: mm

Model No.	Standard Pitch (P)	Standard (E _{std.})	Minimum (E _{min.})	Max (L _o max.)
MSA 15	60	20	5	4000
MSA 20	60	20	6	4000
MSA 25	60	20	7	4000
MSA 30	80	20	8	4000
MSA 35	80	20	8	4000
MSA 45	105	22.5	11	4000
MSA 55	120	30	13	4000
MSA 65	150	35	14	4000

K. Tapped-hole Rail Dimensions

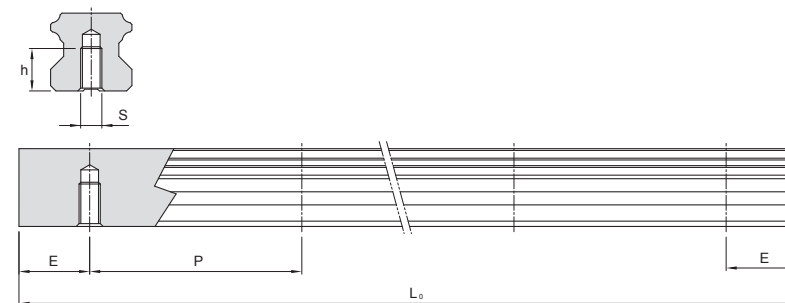

Rail Model	S	h(mm)
MSA 15 T	M5	8
MSA 20 T	M6	10
MSA 25 T	M6	12
MSA 30 T	M8	15
MSA 35 T	M8	17
MSA 45 T	M12	24
MSA 55 T	M14	24
MSA 65 T	M20	30

Dimensions of MSA-A / MSA-LA

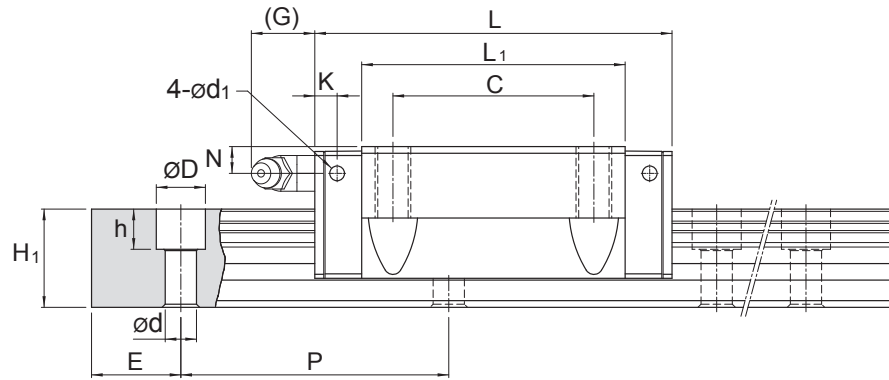

Unit: mm

Model No.	External dimension					Carriage dimension											Grease Nipple
	Height H	Width W	Length L	W ₂	H ₂	B	C	S × ℓ	L ₁	T	T ₁	N	G	K	d ₁		
MSA 15 A	24	47	56.3	16	4.2	38	30	M5×11	39.3	7	11	4.3	7	3.2	3.3	G-M4	
MSA 20 A MSA 20 LA	30	63	72.9 88.8	21.5	5	53	40	M6×10	51.3 67.2	7	10	5	12	5.8	3.3	G-M6	
MSA 25 A MSA 25 LA	36	70	81.6 100.6	23.5	6.5	57	45	M8×16	59 78	11	16	6	12	5.8	3.3	G-M6	
MSA 30 A MSA 30 LA	42	90	97 119.2	31	8	72	52	M10×18	71.4 93.6	11	18	7	12	6.5	3.3	G-M6	
MSA 35 A MSA 35 LA	48	100	111.2 136.6	33	9.5	82	62	M10×21	81 106.4	13	21	8	11.5	8.6	3.3	G-M6	
MSA 45 A MSA 45 LA	60	120	137.7 169.5	37.5	10	100	80	M12×25	102.5 134.3	13	25	10	13.5	10.6	3.3	G-PT1/8	

Note: Request for size 55 and 65 MSA-A / MSA-LA carriage, please refer to MSA-E / MSA-LE carriage type.

Note: The basic dynamic load rating C of ball type is based on the 50 km for nominal life. The conversion between C for 50 km and C₁₀₀ for 100 km is C=1.26 × C₁₀₀.

Note*: Single: Single carriage/ Double: Double carriages closely contacting with each other.

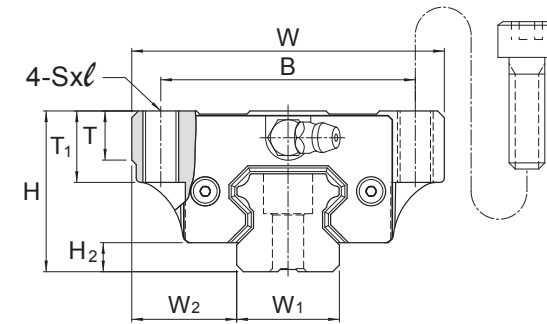
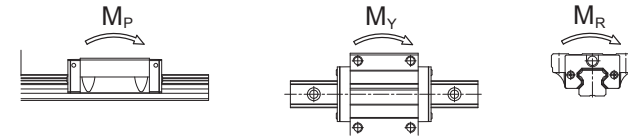

Unit: mm

Model No.	Rail dimension					Basic load rating		Static moment rating				Weight		
	Width W ₁	Height H ₁	Pitch P	E std.	D × h × d	Dynamic C kN	Static C ₀ kN	M _P kN-m		M _Y kN-m		M _R kN-m	Carriage kg	Rail kg/m
								Single*	Double*	Single*	Double*			
MSA 15 A	15	15	60	20	7.5×5.3×4.5	11.8	18.9	0.12	0.68	0.12	0.68	0.14	0.18	1.5
MSA 20 A MSA 20 LA	20	18	60	20	9.5×8.5×6	19.2 23.3	29.5 39.3	0.23 0.39	1.42 2.23	0.23 0.39	1.42 2.23	0.29 0.38	0.4 0.52	2.4
MSA 25 A MSA 25 LA	23	22	60	20	11×9×7	28.1 34.4	42.4 56.6	0.39 0.67	2.20 3.52	0.39 0.67	2.20 3.52	0.48 0.63	0.62 0.82	3.4
MSA 30 A MSA 30 LA	28	26	80	20	14×12×9	39.2 47.9	57.8 77.0	0.62 1.07	3.67 5.81	0.62 1.07	3.67 5.81	0.79 1.05	1.09 1.43	4.8
MSA 35 A MSA 35 LA	34	29	80	20	14×12×9	52.0 63.6	75.5 100.6	0.93 1.60	5.47 8.67	0.93 1.60	5.47 8.67	1.25 1.67	1.61 2.11	6.6
MSA 45 A MSA 45 LA	45	38	105	22.5	20×17×14	83.8 102.4	117.9 157.3	1.81 3.13	10.67 16.95	1.81 3.13	10.67 16.95	2.57 3.43	2.98 3.9	11.5

Dimensions of MSA-E / MSA-LE

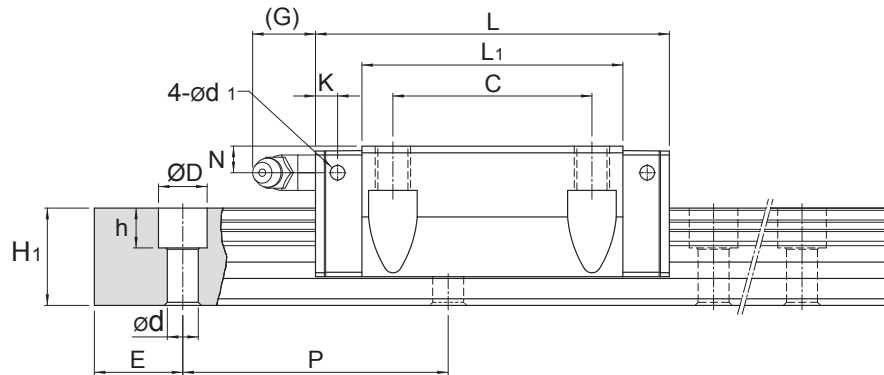

Unit: mm

Model No.	External dimension			Carriage dimension													Grease Nipple
	Height H	Width W	Length L	W ₂	H ₂	B	C	S × l	L ₁	T	T ₁	T ₂	N	G	K	d ₁	
MSA 15 E	24	47	56.3	16	4.2	38	30	M5×7	39.3	7	11	7	4.3	7	3.2	3.3	G-M4
MSA 20 E MSA 20 LE	30	63	72.9 88.8	21.5	5	53	40	M6×10	51.3 67.2	7	10	10	5	12	5.8	3.3	G-M6
MSA 25 E MSA 25 LE	36	70	81.6 100.6	23.5	6.5	57	45	M8×10	59 78	11	16	10	6	12	5.8	3.3	G-M6
MSA 30 E MSA 30 LE	42	90	97 119.2	31	8	72	52	M10×10	71.4 93.6	11	18	10	7	12	6.5	3.3	G-M6
MSA 35 E MSA 35 LE	48	100	111.2 136.6	33	9.5	82	62	M10×13	81 106.4	13	21	13	8	11.5	8.6	3.3	G-M6
MSA 45 E MSA 45 LE	60	120	137.7 169.5	37.5	10	100	80	M12×15	102.5 134.3	13	25	15	10	13.5	10.6	3.3	G-PT 1/8
MSA 55 E MSA 55 LE	70	140	161.5 199.5	43.5	13	116	95	M14×17	119.5 157.5	19	32	17	11	13.5	8.6	3.3	G-PT 1/8
MSA 65 E MSA 65 LE	90	170	199 253	53.5	15	142	110	M16×23	149 203	21.5	37.5	23	19	13.5	8.6	3.3	G-PT 1/8

Note: The basic dynamic load rating C of ball type is based on the 50 km for nominal life. The conversion between C for 50 km and C₁₀₀ for 100 km is C=1.26 × C₁₀₀.

Note *: Single: Single carriage/ Double: Double carriages closely contacting with each other.

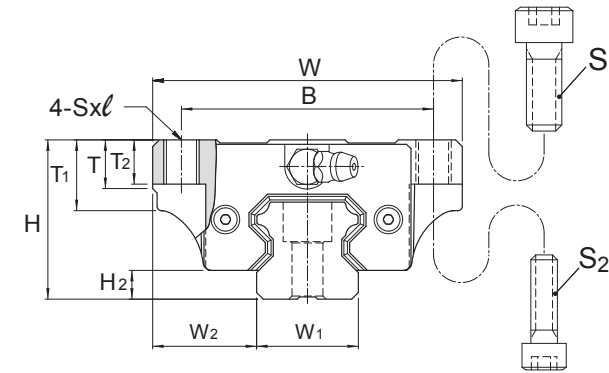
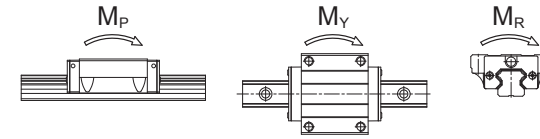

Model No.	Bolt Size	
	S ₁	S ₂
MSA 15	M5	M4
MSA 20	M6	M5
MSA 25	M8	M6
MSA 30	M10	M8
MSA 35	M10	M8
MSA 45	M12	M10
MSA 55	M14	M12
MSA 65	M16	M14

Unit: mm

Model No.	Rail dimension					Basic load rating		Static moment rating				Weight		
	Width W ₁	Height H ₁	Pitch P	E std.	D × h × d	Dynamic C kN	Static C ₀ kN	M _p kN-m		M _y kN-m		M _r kN-m	Carriage kg	Rail kg/m
								Single*	Double*	Single*	Double*			
MSA 15 E	15	15	60	20	7.5×5.3×4.5	11.8	18.9	0.12	0.68	0.12	0.68	0.14	0.18	1.5
MSA 20 E MSA 20 LE	20	18	60	20	9.5×8.5×6	19.2 23.3	29.5 39.3	0.23 0.39	1.42 2.23	0.23 0.39	1.42 2.23	0.29 0.38	0.4 0.52	2.4
MSA 25 E MSA 25 LE	23	22	60	20	11×9×7	28.1 34.4	42.4 56.6	0.39 0.67	2.20 3.52	0.39 0.67	2.20 3.52	0.48 0.63	0.62 0.82	3.4
MSA 30 E MSA 30 LE	28	26	80	20	14×12×9	39.2 47.9	57.8 77.0	0.62 1.07	3.67 5.81	0.62 1.07	3.67 5.81	0.79 1.05	1.09 1.43	4.8
MSA 35 E MSA 35 LE	34	29	80	20	14×12×9	52.0 63.6	75.5 100.6	0.93 1.60	5.47 8.67	0.93 1.60	5.47 8.67	1.25 1.67	1.61 2.11	6.6
MSA 45 E MSA 45 LE	45	38	105	22.5	20×17×14	83.8 102.4	117.9 157.3	1.81 3.13	10.67 16.95	1.81 3.13	10.67 16.95	2.57 3.43	2.98 3.9	11.5
MSA 55 E MSA 55 LE	53	44	120	30	23×20×16	123.6 151.1	169.8 226.4	3.13 5.40	17.57 28.11	3.13 5.40	17.57 28.11	4.50 6.00	4.17 5.49	15.5
MSA 65 E MSA 65 LE	63	53	150	35	26×22×18	198.8 253.5	265.3 375.9	6.11 11.84	33.71 57.32	6.11 11.84	33.71 57.32	8.36 11.84	8.73 11.89	21.9

Dimensions of MSA-S / MSA-LS

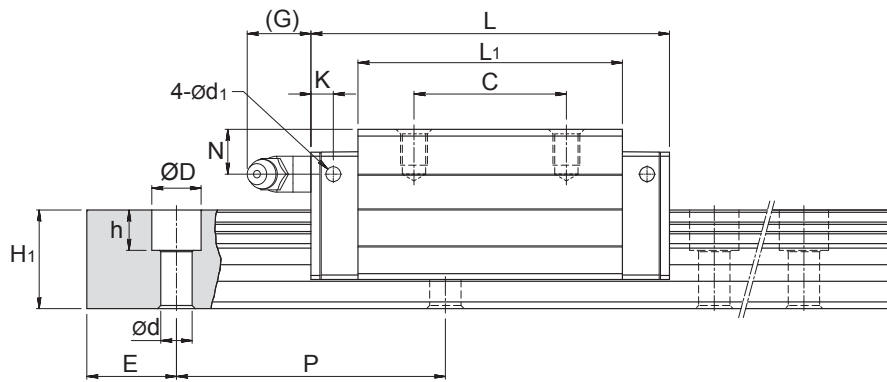

Unit: mm

Model No.	External dimension					Carriage dimension										Grease Nipple
	Height H	Width W	Length L	W ₂	H ₂	B	C	S × l	L ₁	T	N	G	K	d ₁		
MSA 15 S	28	34	56.3	9.5	4.2	26	26	M4×5	39.3	7.2	8.3	7	3.2	3.3	G-M4	
MSA 20 S	30	44	72.9	12	5	32	36	M5×6	51.3	8	5	12	5.8	3.3	G-M6	
MSA 20 LS			88.8				50		67.2							
MSA 25 S	40	48	81.6	12.5	6.5	35	35	M6×8	59	10	10	12	5.8	3.3	G-M6	
MSA 25 LS			100.6				50		78							
MSA 30 S	45	60	97	16	8	40	40	M8×10	71.4	11.7	10	12	6.5	3.3	G-M6	
MSA 30 LS			119.2				60		93.6							
MSA 35 S	55	70	111.2	18	9.5	50	50	M8×12	81	12.7	15	11.5	8.6	3.3	G-M6	
MSA 35 LS			136.6				72		106.4							
MSA 45 S	70	86	137.7	20.5	10	60	60	M10×17	102.5	16	20	13.5	10.6	3.3	G-PT 1/8	
MSA 45 LS			169.5				80		134.3							
MSA 55 S	80	100	161.5	23.5	13	75	75	M12×18	119.5	18	21	13.5	8.6	3.3	G-PT 1/8	
MSA 55 LS			199.5				95		157.5							
MSA 65 S	90	126	199	31.5	15	76	70	M16×20	149	23	19	13.5	8.6	3.3	G-PT 1/8	
MSA 65 LS			253				120		203							

Note: The basic dynamic load rating C of ball type is based on the 50 km for nominal life. The conversion between C for 50 km and C₁₀₀ for 100 km is C=1.26 x C₁₀₀.

Note*: Single: Single carriage/ Double: Double carriages closely contacting with each other.

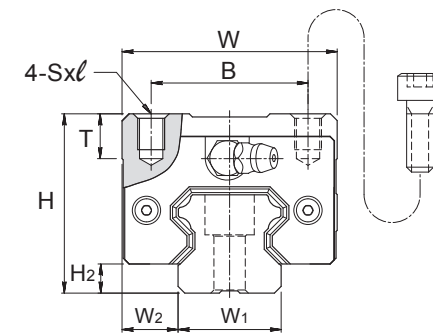
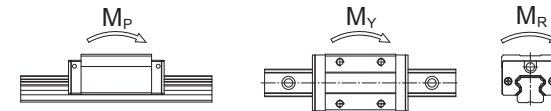

Unit: mm

Model No.	Rail dimension					Basic load rating		Static moment rating				Weight		
	Width W ₁	Height H ₁	Pitch P	E std.	D × h × d	Dynamic C kN	Static C ₀ kN	M _P kN-m		M _Y kN-m		M _R kN-m	Carriage kg	Rail kg/m
								Single	Double	Single	Double			
MSA 15 S	15	15	60	20	7.5×5.3×4.5	11.8	18.9	0.12	0.68	0.12	0.68	0.14	0.18	1.5
MSA 20 S	20	18	60	20	9.5×8.5×6	19.2	29.5	0.23	1.42	0.23	1.42	0.29	0.3	2.4
MSA 20 LS						23.3	39.3	0.39	2.23	0.39	2.23	0.38	0.39	
MSA 25 S	23	22	60	20	11×9×7	28.1	42.4	0.39	2.20	0.39	2.20	0.48	0.52	3.4
MSA 25 LS						34.4	56.6	0.67	3.52	0.67	3.52	0.63	0.68	
MSA 30 S	28	26	80	20	14×12×9	39.2	57.8	0.62	3.67	0.62	3.67	0.79	0.86	4.8
MSA 30 LS						47.9	77.0	1.07	5.81	1.07	5.81	1.05	1.12	
MSA 35 S	34	29	80	20	14×12×9	52.0	75.5	0.93	5.47	0.93	5.47	1.25	1.45	6.6
MSA 35 LS						63.6	100.6	1.60	8.67	1.60	8.67	1.67	1.9	
MSA 45 S	45	38	105	22.5	20×17×14	83.8	117.9	1.81	10.67	1.81	10.67	2.57	2.83	11.5
MSA 45 LS						102.4	157.3	3.13	16.95	3.13	16.95	3.43	3.7	
MSA 55 S	53	44	120	30	23×20×16	123.6	169.8	3.13	17.57	3.13	17.57	4.50	4.12	15.5
MSA 55 LS						151.1	226.4	5.40	28.11	5.40	28.11	6.00	4.91	
MSA 65 S	63	53	150	35	26×22×18	198.8	265.3	6.11	33.71	6.11	33.71	8.36	6.43	21.9
MSA 65 LS						253.5	375.9	11.84	57.32	11.84	57.32	11.84	8.76	

12.2 Compact Type, MSB Series

A. Construction

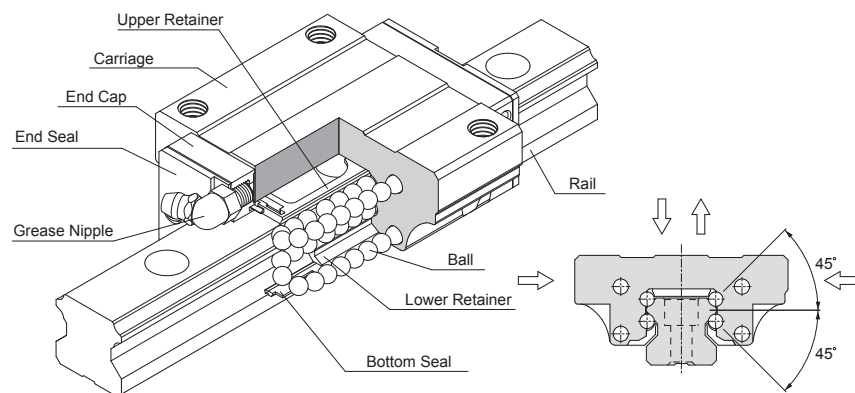

B. Characteristics

The trains of balls are designed to a contact angle of 45° which enables it to bear an equal load in radial, reversed radial and lateral directions. Therefore, it can be applied in any installation direction. Furthermore, MSB series can achieve a well balanced preload for increasing rigidity in four directions while keeping a low frictional resistance. This is especially suit to high precision and high rigidity required motion.

The patent design of lubrication route makes the lubricant evenly distribute in each circulation loop. Therefore, the optimum lubrication can be achieved in any installation direction, and this promotes the performance in running accuracy, service life, and reliability.

Compact, Four-way Equal Load

Compact design of the carriage with the four trains of balls are allocated to a circular contact angle at 45° , thus each train of balls can take up an equal rated load in all four directions. Moreover, a sufficient preload can be achieved to increase rigidity, and this makes it suitable for any kind of installation.

Smooth Movement with Low Noise

The simplified design of circulating system with strengthened synthetic resin accessories makes the movement smooth and quiet.

Self Alignment Capability

The self adjustment is performed spontaneously as the design of face-to-face (DF) circular arc groove. Therefore, the installation error could be compensated even under a preload, and which results in precise and smooth linear motion.

Interchangeability

For interchangeable type of linear guideway, the dimensional tolerances are strictly maintained within a reasonable range, and this has made the random matching of the same size of rails and carriages possible. Therefore, the similar preload and accuracy can be obtained even under the random matching condition. As a result of this advantage, the linear guideway can be stocked as standard parts, the installation and maintenance become more convenient. Moreover, this is also beneficial for shortening the delivery time.

C. Carriage Type

Medium Load

MSB-TE Type

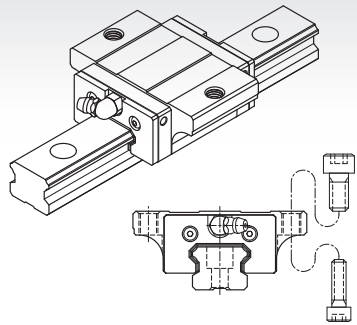

This type offers the installation either from top or bottom side of carriage.

MSB-TS Type

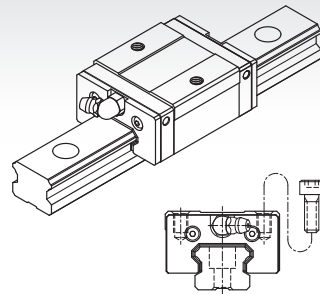

Square type with smaller width and can be installed from top side of carriage.

Ultra Heavy Load

MSB-LE Type

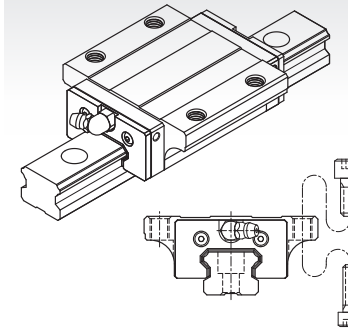

All dimensions are same as MSB-E except the length is longer, which makes it more rigid.

MSB-LS Type

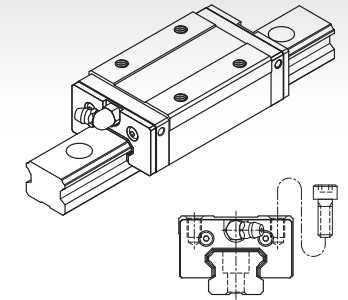

All dimensions are same as MSB-S except the length is longer, which makes it more rigid.

Heavy Load

MSB-E Type

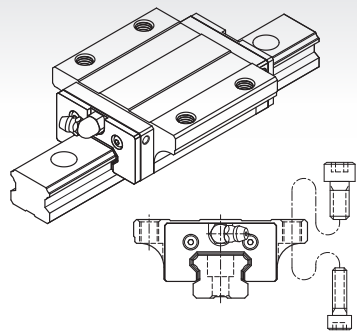

All dimensions are same as MSB-TE except the length is longer, which makes it more rigid.

MSB-S Type

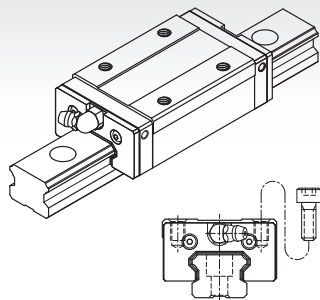

All dimensions are same as MSB-TS except the length is longer, which makes it more rigid.

D. Rail type

Counter bore (R, U type)

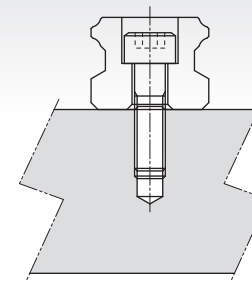

Tapped Hole (T type)

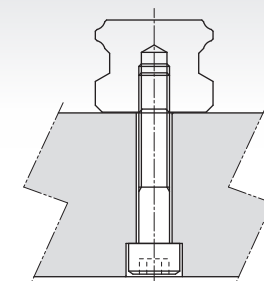

E. Description of Specification

(1) Non-Interchangeable Type

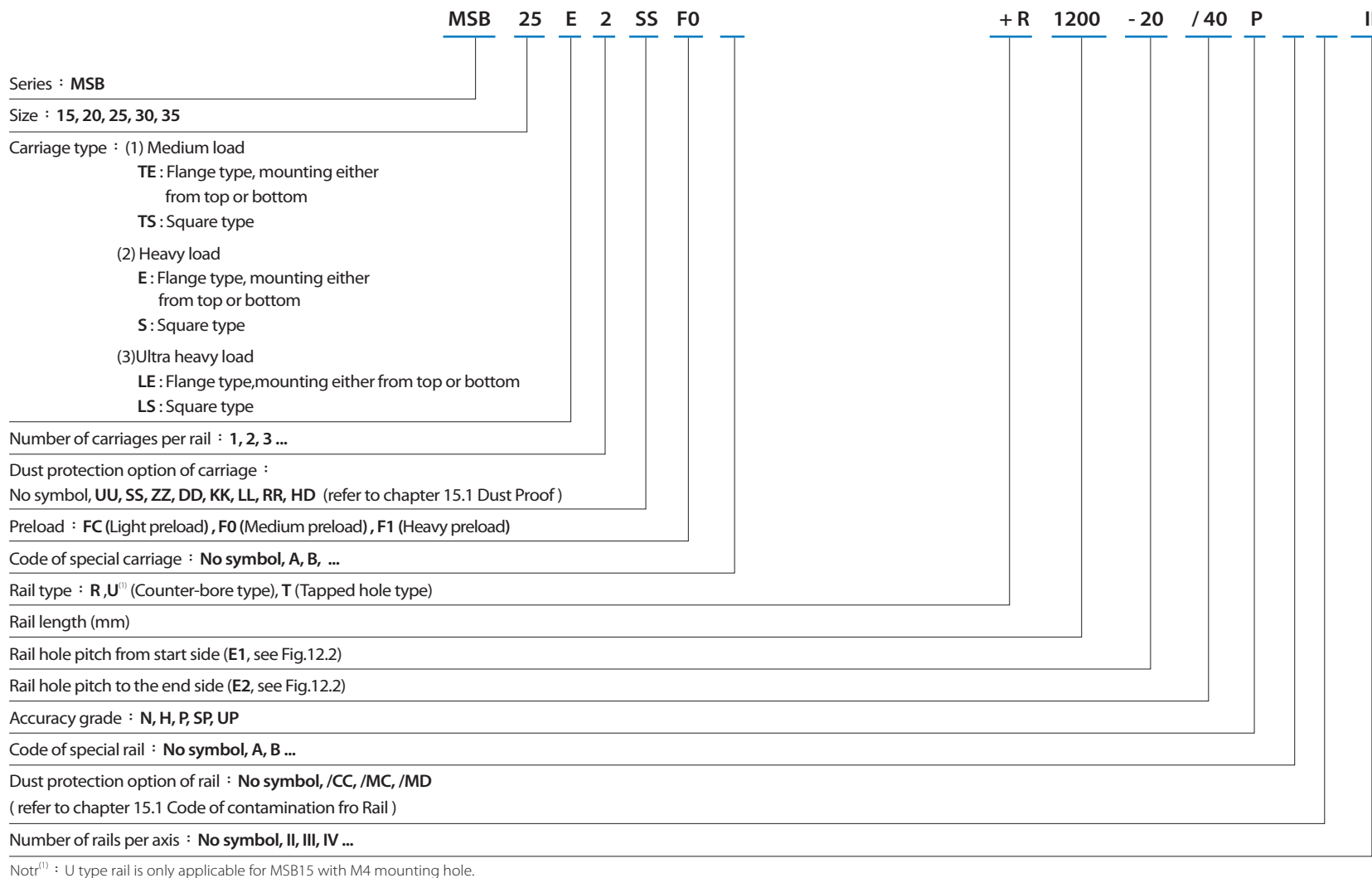

Notr⁽¹⁾ : U type rail is only applicable for MSB15 with M4 mounting hole.

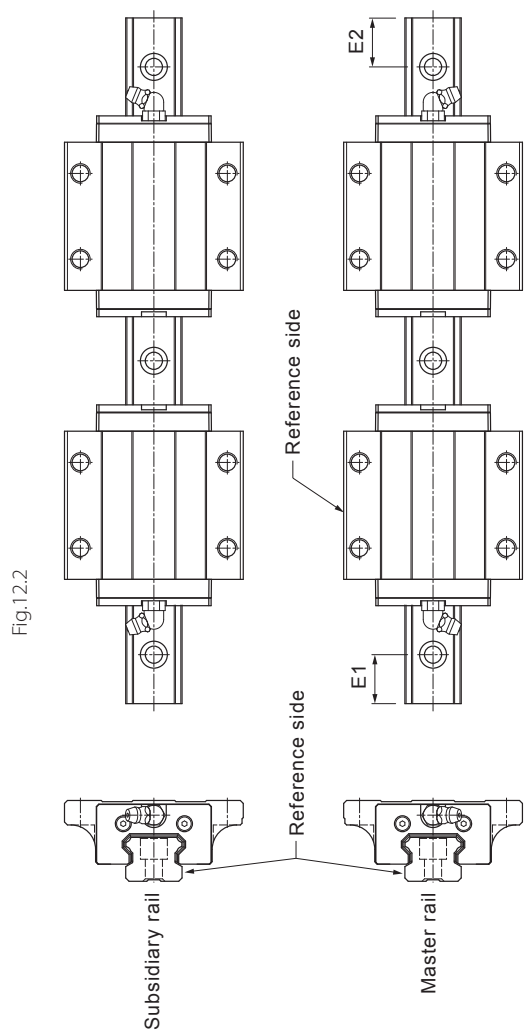

Fig.12.2

(2) Interchangeable Type

Code of Carriage

Series : **MSB**

Size : **15, 20, 25, 30, 35**

Carriage type : (1) Medium load

- TE : Flange type, mounting either from top or bottom
- TS : Square type

(2) Heavy load

- E : Flange type, mounting either from top or bottom
- S : Square type

(3) Ultra heavy load

- LE : Flange type, mounting either from top or bottom
- LS : Square type

Dust protection option of carriage :

No symbol, UU, SS, ZZ, DD, KK, LL, RR, HD (refer to chapter 15.1 Dust Proof)

Preload : **FC** (Light preload) , **F0** (Medium preload)

Accuracy grade : **N, H, P**

Code of special carriage : **No symbol, A, B, ...**

MSB 25 E SS FC N

Code of Rail

Series : **MSB**

Size : **15, 20, 25, 30, 35**

Rail type : **R, U⁽¹⁾** (Counter-bore type), **T** (Tapped hole type)

Rail length (mm)

Rail hole pitch from start side (**E1**, see Fig.12.2)

Rail hole pitch to the end side (**E2**, see Fig.12.2)

Accuracy grade : **N, H, P**

Code of special rail : **No symbol, A, B ...**

Dust protection option of rail : **No symbol, /CC, /MC, /MD**
(refer to chapter 15.1 Code of contamination fro Rail)

MSB 25 R 1200 -20 /40 N

Notr⁽¹⁾ : U type rail is only applicable for MSB15 with M4 mounting hole.

F. Accuracy Grade

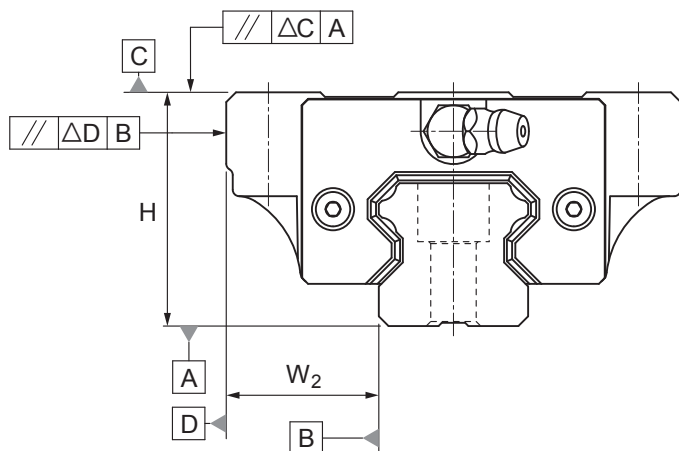

Table 1 Running Parallelism

Rail length (mm)		Running Parallelism Values(μm)				
Above	Or less	N	H	P	SP	UP
0	315	9	6	3	2	1.5
315	400	11	8	4	2	1.5
400	500	13	9	5	2	1.5
500	630	16	11	6	2.5	1.5
630	800	18	12	7	3	2
800	1000	20	14	8	4	2
1000	1250	22	16	10	5	2.5
1250	1600	25	18	11	6	3
1600	2000	28	20	13	7	3.5
2000	2500	30	22	15	8	4
2500	3000	32	24	16	9	4.5
3000	3500	33	25	17	11	5
3500	4000	34	26	18	12	6

A Non-Interchangeable Type

Model No.	Item	Accuracy Grade				
		Normal N	High H	Precision P	Super Precision SP	Ultra Precision UP
15 20	Tolerance for height H	± 0.1	± 0.03	0 -0.03	0 -0.015	0 -0.008
	Height difference ΔH	0.02	0.01	0.006	0.004	0.003
	Tolerance for distance W_2	± 0.1	± 0.03	0 -0.03	0 -0.015	0 -0.008
	Difference in distance $W_2(\Delta W_2)$	0.02	0.01	0.006	0.004	0.003
	Running parallelism of surface C with surface A	ΔC (see the table 1)				
	Running parallelism of surface D with surface B	ΔD (see the table 1)				
25 30 35	Tolerance for height H	± 0.1	± 0.04	0 -0.04	0 -0.02	0 -0.01
	Height difference ΔH	0.02	0.015	0.007	0.005	0.003
	Tolerance for distance W_2	± 0.1	± 0.04	0 -0.04	0 -0.02	0 -0.01
	Difference in distance $W_2(\Delta W_2)$	0.03	0.015	0.007	0.005	0.003
	Running parallelism of surface C with surface A	ΔC (see the table 1)				
	Running parallelism of surface D with surface B	ΔD (see the table 1)				

B Interchangeable Type

Model No.	Item	Accuracy Grade		
		Normal N	High H	Precision P
15 20	Tolerance for height H	±0.1	±0.03	$\begin{matrix} 0 \\ -0.03 \end{matrix}$
	Height difference ΔH	0.02	0.01	0.006
	Tolerance for distance W ₂	±0.1	±0.03	$\begin{matrix} 0 \\ -0.03 \end{matrix}$
	Difference in distance W ₂ (ΔW ₂)	0.02	0.01	0.006
	Running parallelism of surface C with surface A	ΔC (see the table 1)		
	Running parallelism of surface D with surface B	ΔD (see the table 1)		
25 30 35	Tolerance for height H	±0.1	±0.04	$\begin{matrix} 0 \\ -0.04 \end{matrix}$
	Height difference ΔH	0.02	0.015	0.007
	Tolerance for distance W ₂	±0.1	±0.04	$\begin{matrix} 0 \\ -0.04 \end{matrix}$
	Difference in distance W ₂ (ΔW ₂)	0.03	0.015	0.007
	Running parallelism of surface C with surface A	ΔC (see the table 1)		
	Running parallelism of surface D with surface B	ΔD (see the table 1)		

G. Preload Grade

Series	Preload grade		
	Light preload (FC)	Medium preload (F0)	Heavy preload (F1)
MSB15T	0~0.02C	0.03~0.05C	-
MSB20T			
MSB25T			
MSB30T			0.05~0.08C
MSB15	0~0.02C	0.03~0.05C	0.05~0.08C
MSB20			
MSB25			
MSB30			
MSB35			
MSB35L			

Note: C is basic dynamic load rating in above table. Refer to the specification of products, please.

H. The Shoulder Height and Corner Radius for Installation

MSB series

Unit: mm

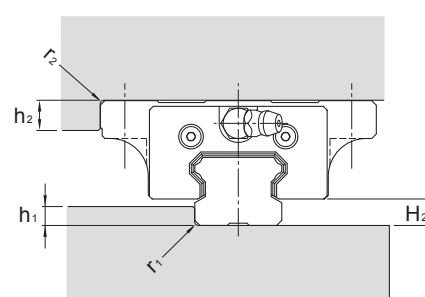

Model No.	r ₁ (max.)	r ₂ (max.)	h ₁	h ₂	H ₂
15	0.5	0.5	3	4	4.5
20	0.5	0.5	4	5	6
25	1	1	5	5	7
30	1	1	7	5	9.5
35	1	1	8	6	9.5

I. Dimensional Tolerance of Mounting Surface

MSB Series

With the self alignment capability, the minor dimensional error in mounting surface could be compensated and achieves smooth linear motion. The tolerances of parallelism between two axes are shown as below.

The parallel deviation between two axes (e_1)

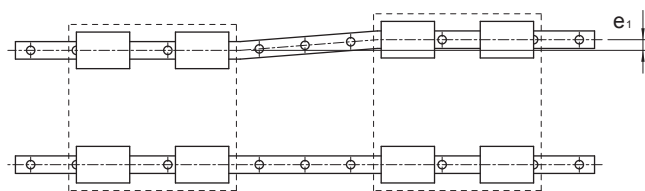

Unit: μm

Model No.	Preload Grade		
	FC	F0	F1
15	25	18	-
20	25	20	18
25	30	22	20
30	40	30	27
35	50	35	30

Level difference between two axes (e_2)

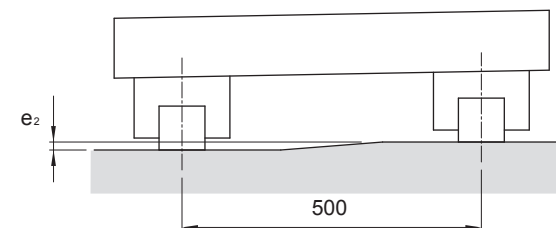

Unit: μm

Model No.	Preload Grade		
	FC	F0	F1
15	130	85	-
20	130	85	50
25	130	85	70
30	170	110	90
35	210	150	120

Note: The permissible values in table are applicable when the span is 500mm wide.

J. Rail Maximum Length and Standrad

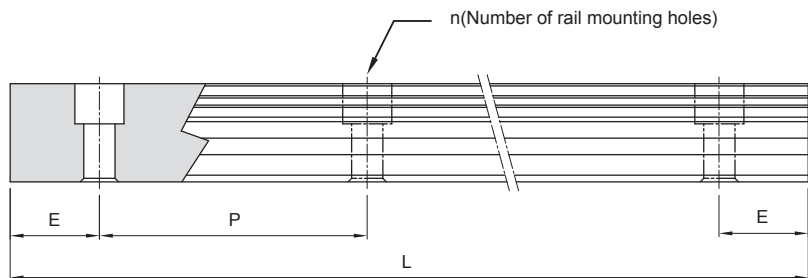

$$L=(n-1) \times P+2 \times E$$

L: Total Length of rail (mm)

n: Nuber of mounting holes

P: Distance between any two holes (mm)

E: Distance from the center of the last hole to the edge (mm)

Unit: mm

Model No.	Standard Pitch (P)	Standard (E _{std.})	Minimum (E _{min.})	Max (L ₀ max.)
MSB 15	60	20	5	4000
MSB 20	60	20	6	4000
MSB 25	60	20	7	4000
MSB 30	80	20	7	4000
MSB 35	80	20	8	4000

K. Tapped-hole Rail Dimensions

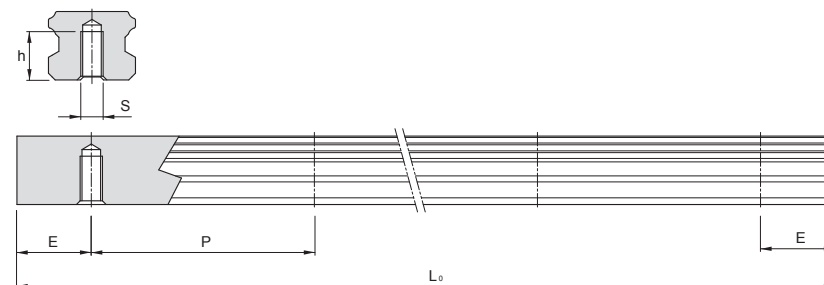

Rail Model	S	h(mm)
MSB 15 T	M5	7
MSB 20 T	M6	9
MSB 25 T	M6	10
MSB 30 T	M8	14
MSB 35 T	M8	16

Dimensions of MSB-TE / MSB-E

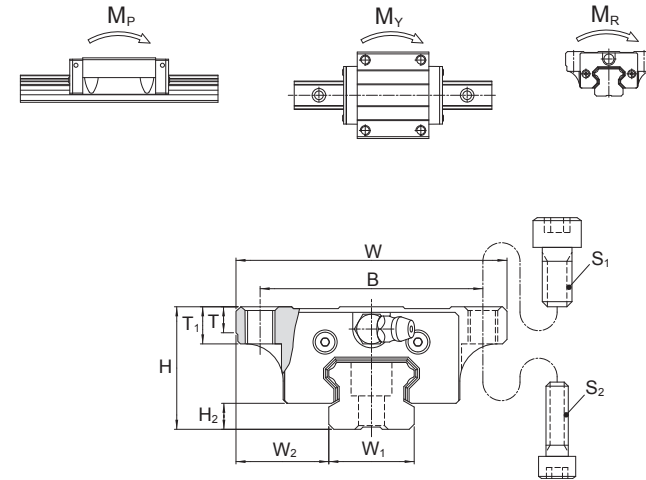
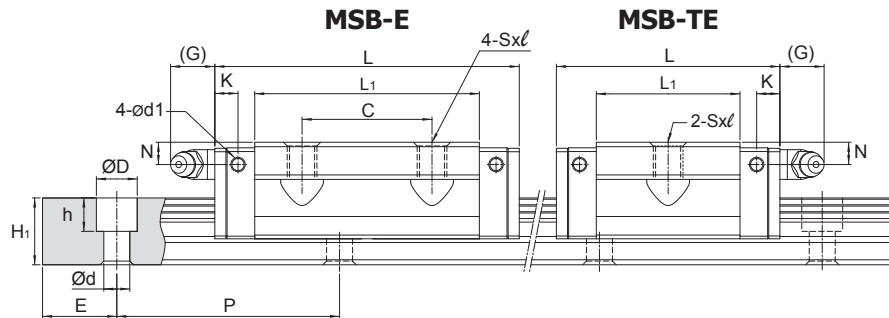

Model No.	Bolt Size	
	S ₁	S ₂
MSB 15	M5	M4
MSB 20	M6	M5
MSB 25	M8	M6
MSB 30	M10	M8
MSB 35	M10	M8

Unit: mm

Model No.	External dimension					Carriage dimension											Grease Nipple
	Height H	Width W	Length L	W ₂	H ₂	B	C	S × ℓ	L ₁	T	T ₁	N	G	K	d ₁		
MSB 15 TE MSB 15 E	24	52	40 57	18.5	4.5	41	- 26	M5×7	23.5 40.5	5	7	5.5	5.5	5.1	3.3	G-M4	
MSB 20 TE MSB 20 E	28	59	48 67	19.5	6	49	- 32	M6×9	29 48	5	9	5.5	12	5.9	3.3	G-M6	
MSB 25 TE MSB 25 E	33	73	60.2 82	25	7	60	- 35	M8×10	38.7 60.5	7	10	6	12	6.3	3.3	G-M6	
MSB 30 TE MSB 30 E	42	90	68 96.7	31	9.5	72	- 40	M10×10	43.3 72	7	10	8	12	6.3	3.3	G-M6	
MSB 35 TE MSB 35 E MSB 35 LE	48	100	78 112 137.5	33	9.5	82	- 50 72	M10×13	46 80 105.5	9	13	8.5	12	9.8	3.3	G-M6	

Note: Rail mounting holes for M3 (6x4.5x3.5) and M4 (7.5x5.3x4.5) are available for MSB15 rail. The codes of rail type are MSB15R for M3 mounting holes, and MSB15U for M4 mounting holes.

Note: The basic dynamic load rating C of ball type is based on the 50 km for nominal life. The conversion between C for 50 km and C₁₀₀ for 100 km is C=1.26 × C₁₀₀.

Note*: Single: Single carriage/ Double: Double carriages closely contacting with each other.

Unit: mm

Model No.	Rail dimension					Basic load rating		Static moment rating				Weight		
	Width W ₁	Height H ₁	Pitch P	E std.	D × h × d	Dynamic C kN	Static C ₀ kN	M _p kN-m		M _v kN-m		M _z kN-m	Carriage kg	Rail kg/m
								Single*	Double*	Single*	Double*			
MSB 15 TE MSB 15 E	15	12.5	60	20	6×4.5×3.5 (7.5×5.3×4.5)	6.7 10.0	9.6 16.9	0.04 0.10	0.26 0.61	0.04 0.10	0.26 0.61	0.07 0.13	0.12 0.21	1.2
MSB 20 TE MSB 20 E	20	15	60	20	9.5×8.5×6	9.7 13.9	14.2 23.6	0.07 0.18	0.44 0.97	0.07 0.18	0.44 0.97	0.14 0.24	0.20 0.34	2
MSB 25 TE MSB 25 E	23	18	60	20	11×9×7	15.6 22.3	22.1 36.9	0.13 0.35	0.91 1.87	0.13 0.35	0.91 1.87	0.26 0.43	0.39 0.60	3
MSB 30 TE MSB 30 E	28	23	80	20	11×9×7	23.1 32.9	31.8 53.1	0.23 0.60	1.39 3.15	0.23 0.60	1.39 3.15	0.45 0.74	0.65 1.08	4.4
MSB 35 TE MSB 35 E MSB 35 LE	34	27.5	80	20	14×12×9	35.7 52.0 63.6	44.0 75.5 100.6	0.34 0.93 1.60	2.81 5.47 8.67	0.34 0.93 1.60	2.81 5.47 8.67	0.75 1.28 1.67	0.91 1.61 1.80	6.2 6.6

Dimensions of MSB-TS / MSB-S

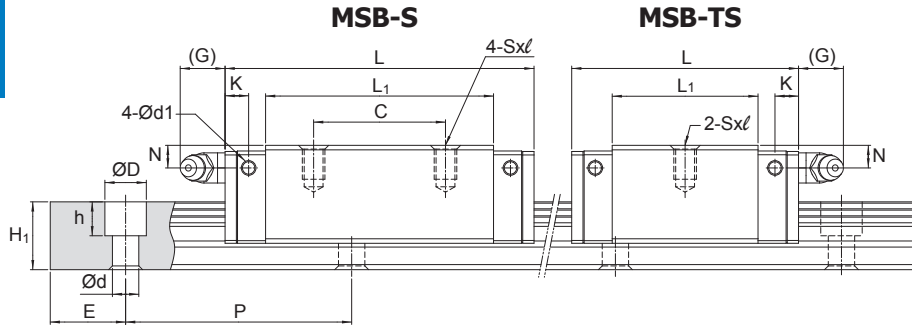

Unit: mm

Model No.	External dimension					Carriage dimension										Grease Nipple
	Height H	Width W	Length L	W ₂	H ₂	B	C	S × l	L ₁	T	N	G	K	d _i		
MSB 15 TS MSB 15 S	24	34	40 57	9.5	4.5	26	- 26	M4×6	23.5 40.5	6	5.5	5.5	5.1	3.3	G-M4	
MSB 20 TS MSB 20 S	28	42	48 67	11	6	32	- 32	M5×7	29 48	6	5.5	12	5.9	3.3	G-M6	
MSB 25 TS MSB 25 S	33	48	60.2 82	12.5	7	35	- 35	M6×9	38.7 60.5	8	6	12	6.3	3.3	G-M6	
MSB 30 TS MSB 30 S	42	60	68 96.7	16	9.5	40	- 40	M8×12	43.3 72	8	8	12	6.3	3.3	G-M6	
MSB 35 TS MSB 35 S MSB 35 LS	48	70	78 112 137.5	18	9.5	50	- 50 72	M8×12	46 80 105.5	12.5	8.5	11.5	9.8	3.3	G-M6	

Note: Rail mounting holes for M3 (6x4.5x3.5) and M4 (7.5x5.3x4.5) are available for MSB15 rail. The codes of rail type are MSB15R for M3 mounting holes, and MSB15U for M4 mounting holes.

Note: The basic dynamic load rating C of ball type is based on the 50 km for nominal life. The conversion between C for 50 km and C₁₀₀ for 100 km is C=1.26 × C₁₀₀.

Note*: Single: Single carriage/ Double: Double carriages closely contacting with each other.

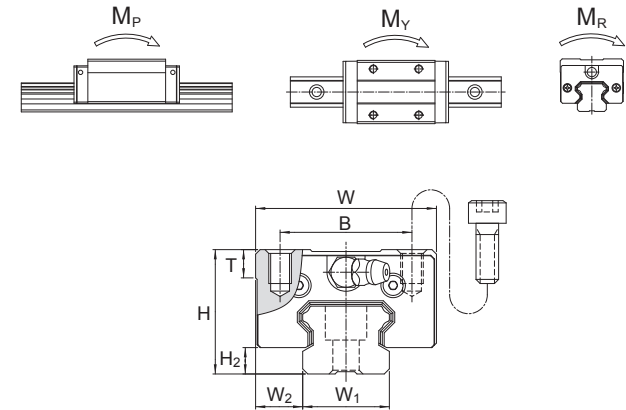

Unit: mm

Model No.	Rail dimension					Basic load rating		Static moment rating				Weight		
	Width W ₁	Height H ₁	Pitch P	E std.	D × h × d	Dynamic C kN	Static C ₀ kN	M _p kN-m		M _v kN-m		M _r kN-m	Carriage kg	Rail kg/m
								Single*	Double*	Single*	Double*			
MSB 15 TS MSB 15 S	15	12.5	60	20	6×4.5×3.5 (7.5×5.3×4.5)	6.7 10.0	9.6 16.9	0.04 0.10	0.26 0.61	0.04 0.10	0.26 0.61	0.07 0.13	0.09 0.16	1.2
MSB 20 TS MSB 20 S	20	15	60	20	9.5×8.5×6	9.7 13.9	14.2 23.6	0.07 0.18	0.44 0.97	0.07 0.18	0.44 0.97	0.14 0.24	0.16 0.26	2
MSB 25 TS MSB 25 S	23	18	60	20	11×9×7	15.6 22.3	22.1 36.9	0.13 0.35	0.91 1.87	0.13 0.35	0.91 1.87	0.26 0.43	0.29 0.45	3
MSB 30 TS MSB 30 S	28	23	80	20	11×9×7	23.1 32.9	31.8 53.1	0.23 0.60	1.39 3.15	0.23 0.60	1.39 3.15	0.45 0.74	0.52 0.82	4.4
MSB 35 TS MSB 35 S MSB 35 LS	34	27.5	80	20	14×12×9	35.7 52.0 63.6	44.0 75.5 100.6	0.34 0.93 1.60	2.81 5.47 8.67	0.34 0.93 1.60	2.81 5.47 8.67	0.75 1.28 1.67	0.81 1.13 1.49	6.2

12.3 Full Roller Type, MSR Series

A. Construction

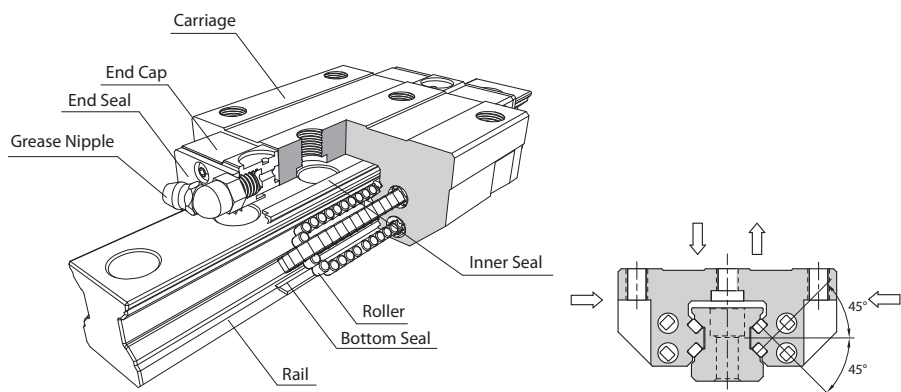

B. Characteristics

The full roller type linear guideway, MSR series, equip with rollers instead of the ball, and therefore the MSR series can provide higher rigidity and loading than the normal type with the same size. Especially suit for the requests of high accuracy, heavy load and high rigidity.

Ultra Heavy Load

MSR linear guideway through rollers have a line contact with carriage and rail. Relative to the general type linear guideway through balls have a point contact; the MSR type linear guideway can offer lower elastic deformation while bearing the same load. Base on the rollers have the same outer diameter with balls, the roller can bear the heavier load. The excellent characteristics of high rigidity and ultra heavy load can suitable for the high accuracy application that heavy load is processed even more.

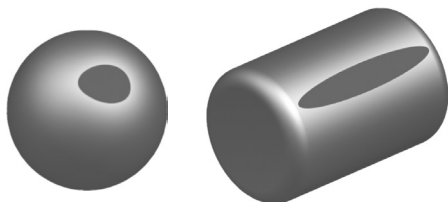

The Optimization Design of Four Directional Load

Through the structure stress analysis of finite element method, SMR series have four trains of rollers are designed to a contact angle of 45° and the section design for high rigidity. Except for bearing heavier loads in radial, reversed radial and lateral directions, a sufficient preload can be achieved to increase rigidity, and this makes it suitable for any kind of installation.

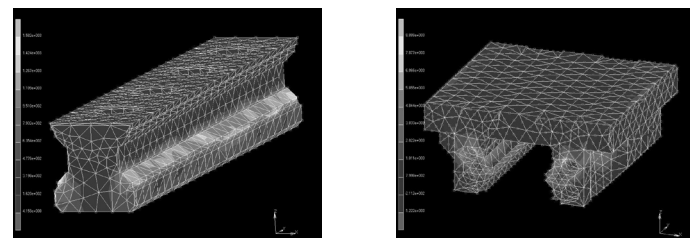

Ultra High Rigidity

Test data of rigidity

- Test samples : Ball type MSA30LE with preload F1
- Full roller type MSR30LE with preload F1
- Roller chain type SMR30LE with preload F1

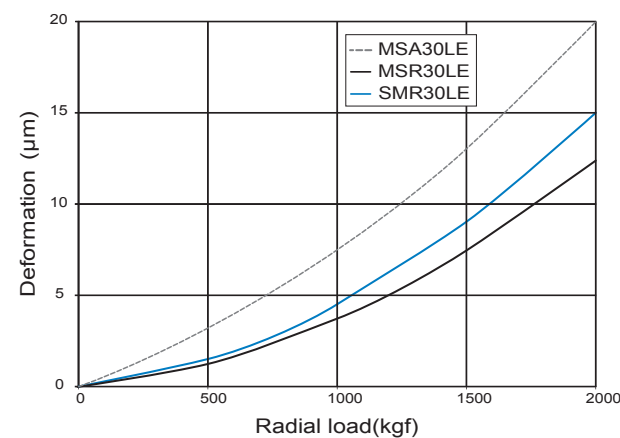
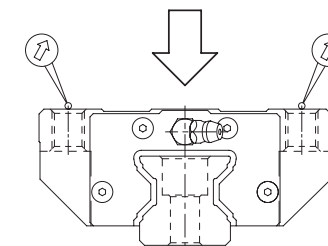

C. Carriage Type

Heavy Load

MSR-E Type

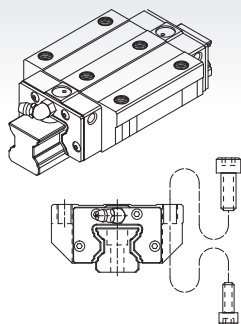

This type offers the installation either from top or bottom side of carriage.

MSR-S Type

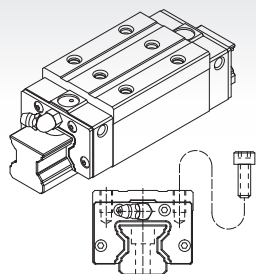

Square type with smaller width and can be installed from top side of carriage.

Ultra Heavy Load

MSR-LE Type

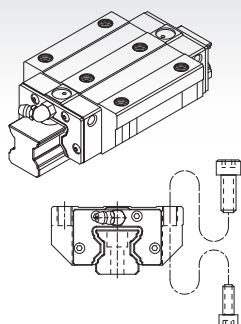

All dimensions are same as MSR-E except the length is longer, which makes it more rigid.

MSR-LS Type

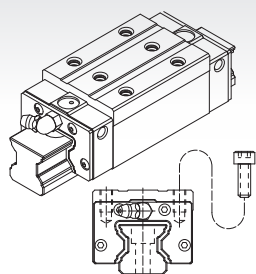

All dimensions are same as MSR-S except the length is longer, which makes it more rigid.

D. Rail Type

Counter bore (R type)

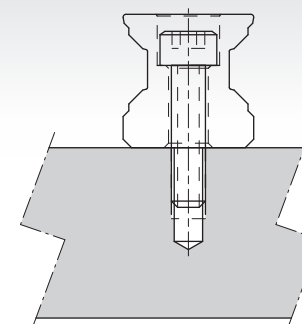

Tapped Hole (T type)

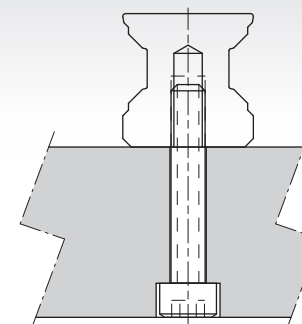

E. Description of Specification

(1) Non-interchangeable Type

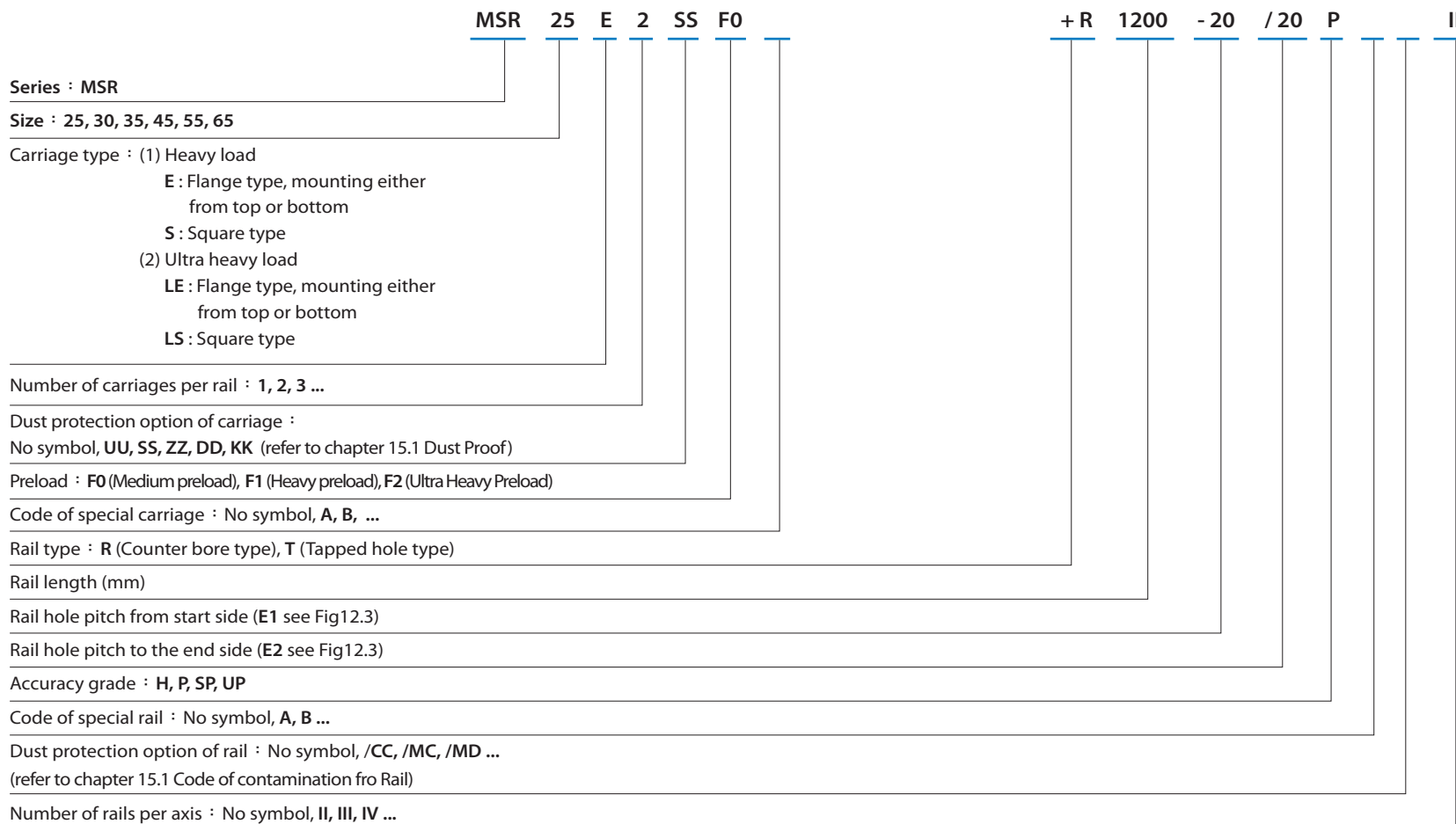
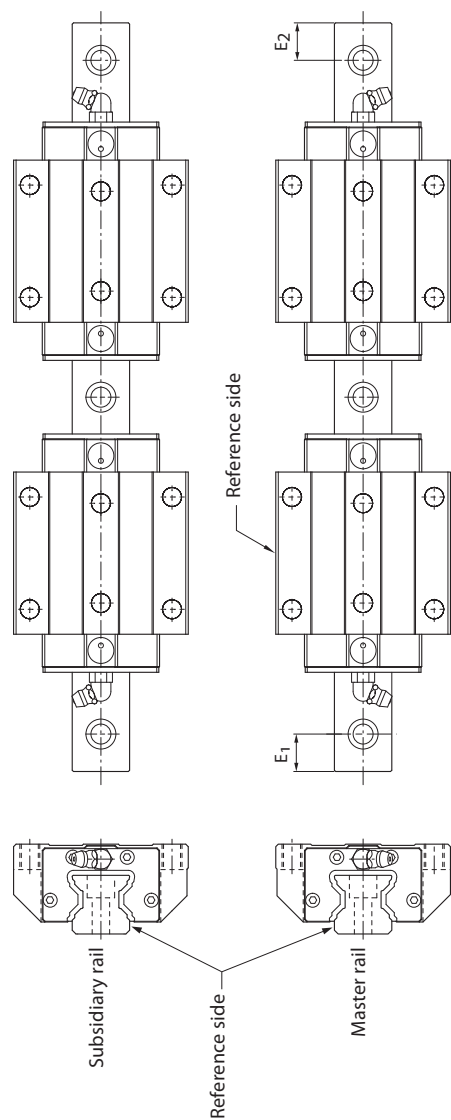

Fig. 12.3



(2) Interchangeable Type

Code of Carriage

Series : MSR

Size : 25, 30, 35, 45, 55, 65

Carriage type : (1) Heavy load

E : Flange type, mounting either from top or bottom

S : Square type

(2) Ultra heavy load

LE : Flange type, mounting either from top or bottom

LS : Square type

Dust protection option of carriage : No symbol, UU, SS, ZZ, DD, KK (refer to chapter 15.1 Dust Proof)

Preload : F0 (Medium preload), F1 (Heavy preload)

Accuracy grade : H, P

Code of special carriage : No symbol, A, B, ...

MSR 25 E SS F0 H

Code of Rail

Series : MSR

Size : 25, 30, 35, 45, 55, 65

Rail type : R (Counter-bore type), T (Tapped hole type)

Rail length (mm)

Rail hole pitch from start side (E1, see Fig.12.3)

Rail hole pitch to the end side (E2, see Fig.12.3)

Accuracy grade : H, P

Code of special rail : No symbol, A, B ...

Dust protection option of rail : No symbol, /CC, /MC, /MD ... (refer to chapter 15.1 Code of contamination fro Rail)

MSR 25 R 1200 -20 /20 H

F. Accuracy Grade

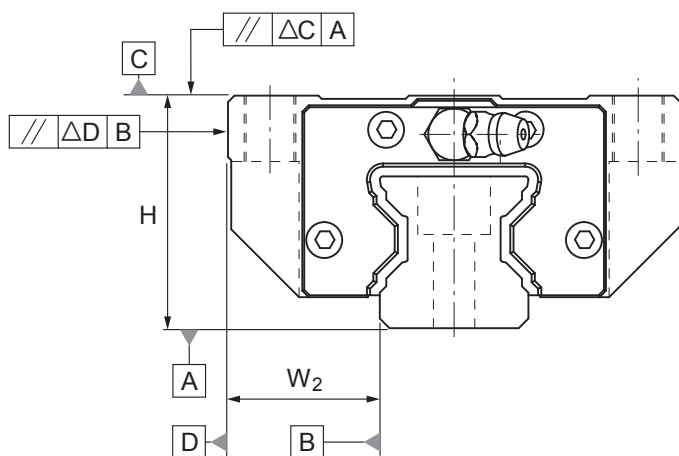

Table 1 Running Parallelism

Rail length (mm)		Running Parallelism Values(μm)			
Above	Or less	H	P	SP	UP
0	315	6	3	2	1.5
315	400	8	4	2	1.5
400	500	9	5	2	1.5
500	630	11	6	2.5	1.5
630	800	12	7	3	2
800	1000	14	8	4	2
1000	1250	16	10	5	2.5
1250	1600	18	11	6	3
1600	2000	20	13	7	3.5
2000	2500	22	15	8	4
2500	3000	24	16	9	4.5
3000	3500	25	17	11	5
3500	4000	26	18	12	6

A Non-Interchangeable Type

Model No.	Item.	Accuracy Grade			
		High H	Precision P	Super Precision SP	Ultra Precision UP
25 30 35	Tolerance for height H	± 0.04	0 -0.04	0 -0.02	0 -0.01
	Height difference ΔH	0.015	0.007	0.005	0.003
	Tolerance for distance W_2	± 0.04	0 -0.04	0 -0.02	0 -0.01
	Difference in distance $W_2(\Delta W_2)$	0.015	0.007	0.005	0.003
	Running parallelism of surface C with surface A	ΔC (see the table 1)			
	Running parallelism of surface D with surface B	ΔD (see the table 1)			
45 55	Tolerance for height H	± 0.05	0 -0.05	0 -0.03	0 -0.02
	Height difference ΔH	0.015	0.007	0.005	0.003
	Tolerance for distance W_2	± 0.05	0 -0.05	0 -0.03	0 -0.02
	Difference in distance $W_2(\Delta W_2)$	0.02	0.01	0.007	0.005
	Running parallelism of surface C with surface A	ΔC (see the table 1)			
	Running parallelism of surface D with surface B	ΔD (see the table 1)			
65	Tolerance for height H	± 0.07	0 -0.07	0 -0.05	0 -0.03
	Height difference ΔH	0.02	0.01	0.007	0.005
	Tolerance for distance W_2	± 0.07	0 -0.07	0 -0.05	0 -0.03
	Difference in distance $W_2(\Delta W_2)$	0.025	0.015	0.01	0.007
	Running parallelism of surface C with surface A	ΔC (see the table 1)			
	Running parallelism of surface D with surface B	ΔD (see the table 1)			

B Interchangeable Type

Model No.	Item.	Accuracy Grade	
		High H	Precision P
25 30 35	Tolerance for height H	±0.04	0 -0.04
	Height difference ΔH	0.015	0.007
	Tolerance for distance W ₂	±0.04	0 -0.04
	Difference in distance W ₂ (ΔW ₂)	0.015	0.007
	Running parallelism of surface C with surface A	ΔC (see the table 1)	
	Running parallelism of surface D with surface B	ΔD (see the table 1)	
45 55	Tolerance for height H	±0.05	0 -0.05
	Height difference ΔH	0.015	0.007
	Tolerance for distance W ₂	±0.05	0 -0.05
	Difference in distance W ₂ (ΔW ₂)	0.02	0.01
	Running parallelism of surface C with surface A	ΔC (see the table 1)	
	Running parallelism of surface D with surface B	ΔD (see the table 1)	
65	Tolerance for height H	±0.07	0 -0.07
	Height difference ΔH	0.02	0.01
	Tolerance for distance W ₂	±0.07	0 -0.07
	Difference in distance W ₂ (ΔW ₂)	0.025	0.015
	Running parallelism of surface C with surface A	ΔC (see the table 1)	
	Running parallelism of surface D with surface B	ΔD (see the table 1)	

G. Preload Grade

Series	Preload grade		
	Medium preload (F0)	Heavy preload(F1)	Ultra heavy preload(F2)
MSR25	0.04~0.06C	0.07~0.09C	0.12~0.14C
MSR30			
MSR35			
MSR45			
MSR55			
MSR25L	0.04~0.06C	0.07~0.09C	0.12~0.14C
MSR30L			
MSR35L			
MSR45L			
MSR55L			
MSR65L			

Note: C is basic dynamic load rating in above table. Refer to the specification of products, please.

H. The Shoulder Height and Corner Radius for Installation

MSR series

Unit: mm

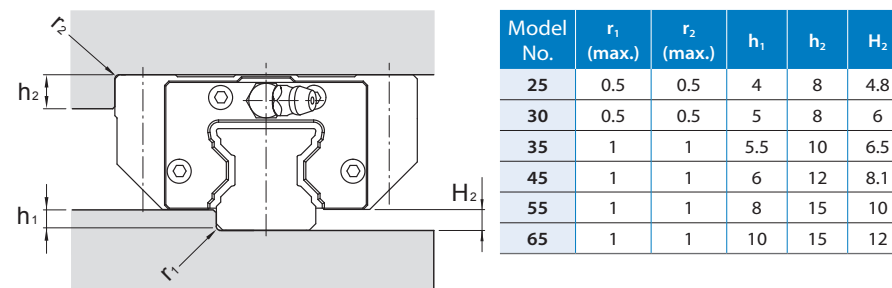

I. Dimensional Tolerance of Mounting Surface

MSR Series

With the high rigidity, the minor dimensional error in mounting surface could be compensated and achieves smooth linear motion. The tolerances of parallelism between two axes are shown as below.

The parallel deviation between two axes (e_1)

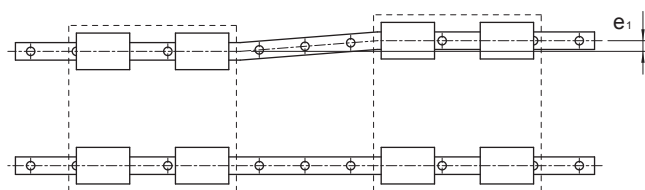

Unit: μm

Model No.	Preload Grade		
	F0	F1	F2
25	9	7	5
30	11	8	6
35	14	10	7
45	17	13	9
55	21	14	11
65	27	18	14

Level difference between two axes (e_2)

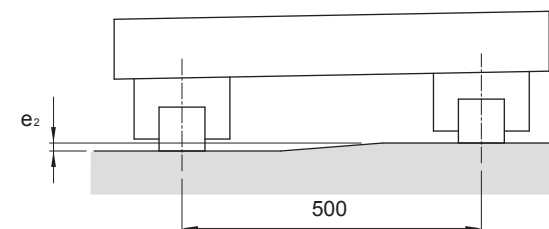

Unit: μm

Model No.	Preload Grade		
	F0	F1	F2
25	150	105	55
30			
35			
45			
55			
65			

Note: The permissible values in table are applicable when the span is 500mm wide.

J. Rail Maximum Length and Standrad

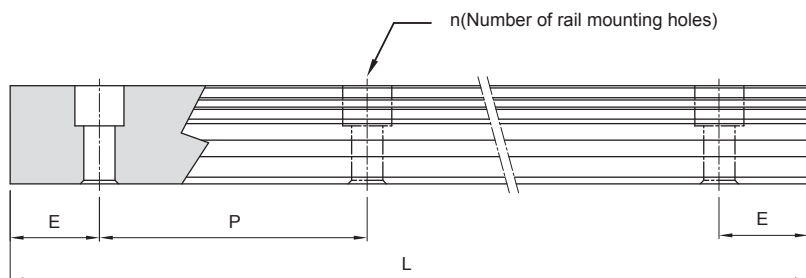

$$L = (n-1) \times P + 2 \times E$$

L: Total Length of rail (mm)

n: Nuber of mounting holes

P: Distance between any two holes (mm)

E: Distance from the center of the last hole to the edge (mm)

Unit: mm

Model No.	Standard Pitch (P)	Standard (E _{std.})	Minimum (E _{min.})	Max (L _o max.)
MSR 25	30	20	7	4000
MSR 30	40	20	8	4000
MSR 35	40	20	8	4000
MSR 45	52.5	22.5	11	4000
MSR 55	60	30	13	4000
MSR 65	75	35	14	4000

K. Tapped-hole Rail Dimensions

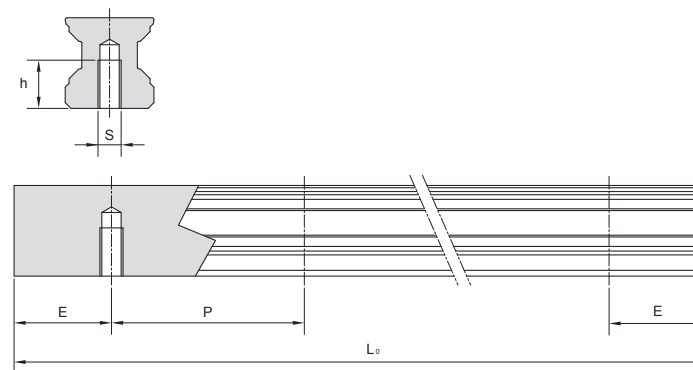

Rail Model	S	h(mm)
MSR 25 T	M6	12
MSR 30 T	M8	15
MSR 35 T	M8	17
MSR 45 T	M12	24
MSR 55 T	M14	24
MSR 65 T	M20	30

Dimensions of MSR-E / MSR-LE

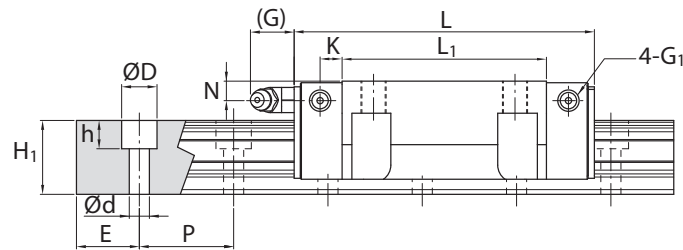
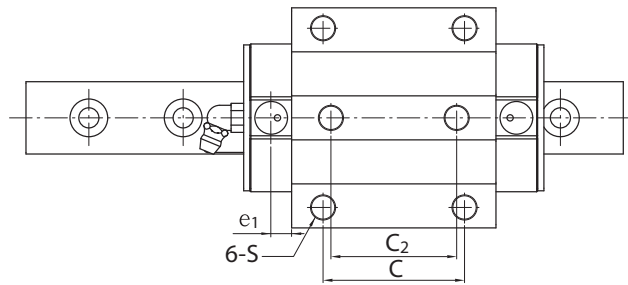

Unit: mm

Model No.	External dimension				Carriage dimension														Grease Nipple	
	Height H	Width W	Length L	W ₂	H ₂	B	C	C ₂	S	L ₁	T	T ₁	T ₂	T ₃	N	G	K	e ₁		G ₁
MSR 25 E MSR 25 LE	36	70	97.5 115.5	23.5	4.8	57	45	40	M8	65.5 83.5	9.5	20.2	10	5.8	6	12	6.6	6.5	M6	G-M6
MSR 30 E MSR 30 LE	42	90	112.4 135.2	31	6	72	52	44	M10	75.9 98.7	10	21.6	13	6.7	7	12	8	7	M6	G-M6
MSR 35 E MSR 35 LE	48	100	125.3 153.5	33	6.5	82	62	52	M10	82.3 110.5	12	27.5	15	9.5	8	12	8	7	M6	G-M6
MSR 45 E MSR 45 LE	60	120	154.2 189.4	37.5	8	100	80	60	M12	106.5 141.7	14.5	35.5	15	12.5	10	13.5	10	10	M6	G-PT 1/8
MSR 55 E MSR 55 LE	70	140	185.4 235.4	43.5	10	116	95	70	M14	129.5 179.5	17.5	41	18	15.5	11	13.5	12	7.95	M6	G-PT 1/8
MSR 65 LE	90	170	302	53.5	12	142	110	82	M16	230	19.5	56	20	26	16.5	13.5	15	15	M6	G-PT 1/8

Note*: Single: Single carriage/ Double: Double carriages closely contacting with each other.

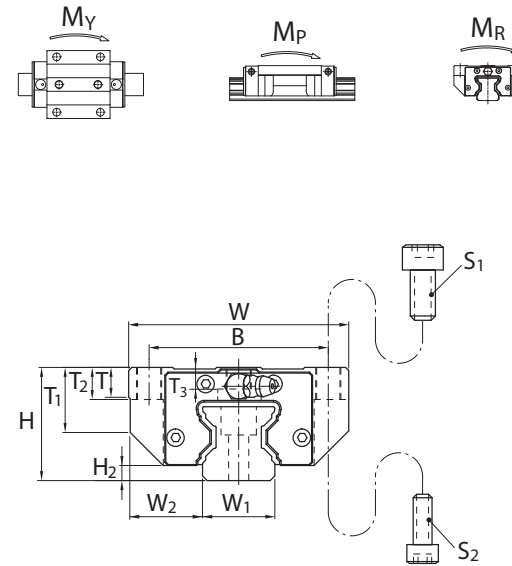

Model No.	Bolt Size	
	S ₁	S ₂
MSR 25	M8	M6
MSR 30	M10	M8
MSR 35	M10	M8
MSR 45	M12	M10
MSR 55	M14	M12
MSR 65	M16	M14

Unit: mm

Model No.	Rail dimension				Basic load rating Dynamic C kN	Static C ₀ kN	Static moment rating				Weight			
	Width W ₁	Height H ₁	Pitch P	E std.			D × h × d	M _y kN-m		M _x kN-m		M _r kN-m	Carriage kg	Rail kg/m
								Single*	Double*	Single*	Double*			
MSR 25 E MSR 25 LE	23	23.5	30	20	11×9×7	29.6 36.3	63.8 82.9	0.65 1.08	3.82 5.94	0.65 1.08	3.82 5.94	0.73 0.95	0.75 0.95	3.5
MSR 30 E MSR 30 LE	28	27.5	40	20	14×12×9	42.8 54.0	91.9 124.0	1.09 1.96	6.38 10.60	1.09 1.96	6.38 10.60	1.27 1.75	1.4 1.72	5
MSR 35 E MSR 35 LE	34	30.5	40	20	14×12×9	57.9 73.9	123.5 169.0	1.59 2.94	9.56 16.18	1.59 2.94	9.56 16.18	2.09 2.85	1.95 2.45	7
MSR 45 E MSR 45 LE	45	37	52.5	22.5	20×17×14	92.8 117.2	193.8 261.6	3.28 5.90	18.76 31.32	3.28 5.90	18.76 31.32	4.40 5.94	3.9 4.5	11.2
MSR 55 E MSR 55 LE	53	43	60	30	23×20×16	132.8 172.5	270.0 378.0	5.49 10.60	31.18 55.58	5.49 10.60	31.18 55.58	7.33 10.28	6 7.9	15.6
MSR 65 LE	63	52	75	35	26×22×18	277.0	624.0	22.50	117.87	22.50	117.87	20.02	17.6	22.4

Dimensions of MSR-S / MSR-LS

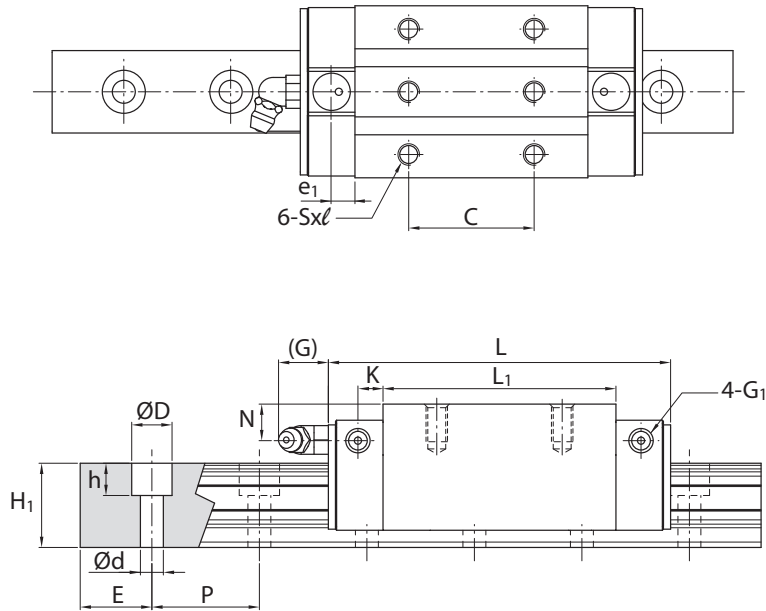

Unit: mm

Model No.	External dimension					Carriage dimension												Grease Nipple
	Height H	Width W	Length L	W_2	H_2	B	C	S	ℓ	L_1	T	N	G	K	e_1	G_1		
MSR 25 S MSR 25 LS	40	48	97.5 115.5	12.5	4.8	35	35 50	M6	9	65.5 83.5	9.5	10	12	6.6	6.5	M6	G-M6	
MSR 30 S MSR 30 LS	45	60	112.4 135.2	16	6	40	40 60	M8	12	75.9 98.7	10	10	12	8	7	M6	G-M6	
MSR 35 S MSR 35 LS	55	70	125.3 153.5	18	6.5	50	50 72	M8	14	82.3 110.5	12	15	12	8	7	M6	G-M6	
MSR 45 S MSR 45 LS	70	86	154.2 189.4	20.5	8	60	60 80	M10	19	106.5 141.7	17	20	13.5	10	10	M6	G-PT 1/8	
MSR 55 S MSR 55 LS	80	100	185.4 235.4	23.5	10	75	75 95	M12	19	129.5 179.5	18	21	13.5	12	7.95	M6	G-PT 1/8	
MSR 65 LS	90	126	302	31.5	12	76	120	M16	20	230	19.5	16.5	13.5	15	15	M6	G-PT 1/8	

Note*: Single: Single carriage/ Double: Double carriages closely contacting with each other.

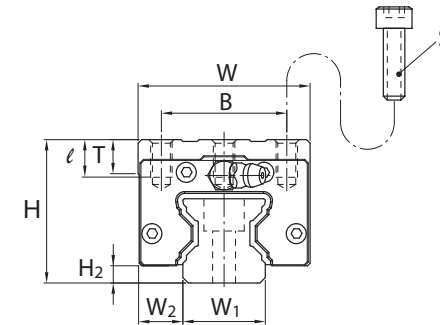
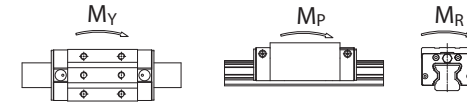

Unit: mm

Model No.	Rail dimension					Basic load rating		Static moment rating				Weight		
	Width W_1	Height H_1	Pitch P	E std.	$D \times h \times d$	Dynamic C kN	Static C_0 kN	M_p kN-m		M_Y kN-m		M_R kN-m	Carriage kg	Rail kg/m
								Single*	Double*	Single*	Double*			
MSR 25 S MSR 25 LS	23	23.5	30	20	11×9×7	29.6 36.3	63.8 82.9	0.65 1.08	3.82 5.94	0.65 1.08	3.82 5.94	0.73 0.95	0.65 0.85	3.5
MSR 30 S MSR 30 LS	28	27.5	40	20	14×12×9	42.8 54.0	91.9 124.0	1.09 1.96	6.38 10.60	1.09 1.96	6.38 10.60	1.27 1.72	1 1.22	5
MSR 35 S MSR 35 LS	34	30.5	40	20	14×12×9	57.9 73.9	123.5 169.0	1.59 2.94	9.56 16.18	1.59 2.94	9.56 16.18	2.09 2.85	1.65 2.15	7
MSR 45 S MSR 45 LS	45	37	52.5	22.5	20×17×14	92.8 117.2	193.8 261.6	3.28 5.90	18.76 31.32	3.28 5.90	18.76 31.32	4.40 5.94	3.2 4.1	11.2
MSR 55 S MSR 55 LS	53	43	60	30	23×20×16	132.8 172.5	270.0 378.0	5.49 10.60	31.18 55.58	5.49 10.60	31.18 55.58	7.33 10.26	5.1 7	15.6
MSR 65 LS	63	52	75	35	26×22×18	277.0	624.0	22.50	117.87	22.50	117.87	20.02	13.3	22.4

12.4 Miniature Type, MSC / MSD Stainless Steel Series

A. Construction

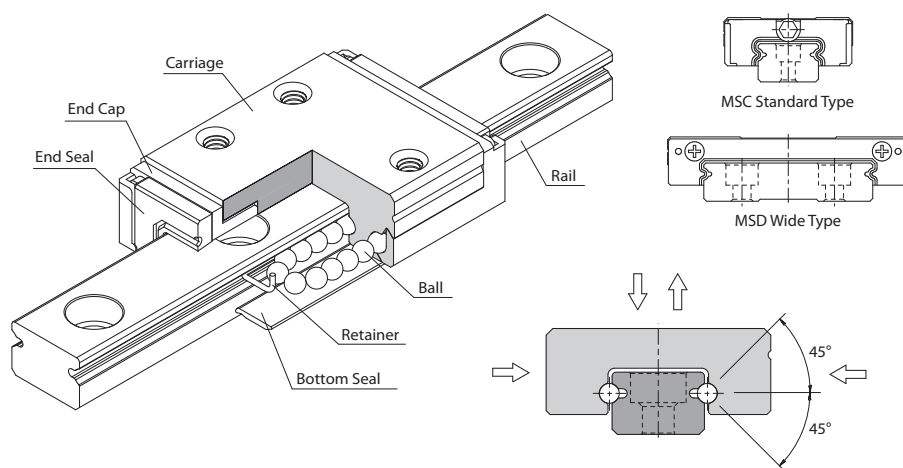

B. Characteristics

MSC st ows with Gothic-arch groove and designed to contact angle of 45° which enables it to bear an equal load in radial, reversed radial and lateral directions. Furthermore, ultra compact and low friction resistance design is suit to compact equipment. The lubrication route makes the lubricant evenly distribute in each circulation loop. Therefore, the optimum lubrication can be achieved in any installation direction, and this promotes the performance in running accuracy, service life, and reliability.

Four-way Equal Load

The two trains of balls are allocated to a Gothic-arch groove contact angle at 45° , thus each train of balls can take up an equal rated load in all four directions.

Ultra Compact

The ultra compact design is suit to the compact application with limited in space.

Ball Retainer

Design with ball retainer can prevent ball form dropping.

Smooth Movement with Low Noise

The simplified design of circulating system with strengthened synthetic resin accessories makes the movement smooth and quiet.

Interchangeability

For interchangeable type of linear guideway, the dimensional tolerances are strictly maintained within a reasonable range, and this has made the random matching of the same size of rails and carriages possible. Therefore, the similar preload and accuracy can be obtained even under the random matching condition. As a result of this advantage, the linear guideway can be stocked as standard parts, the installation and maintenance become more convenient. Moreover, this is also beneficial for shortening the delivery time.

C. Description of Specification

(1) Non-interchangeable Type

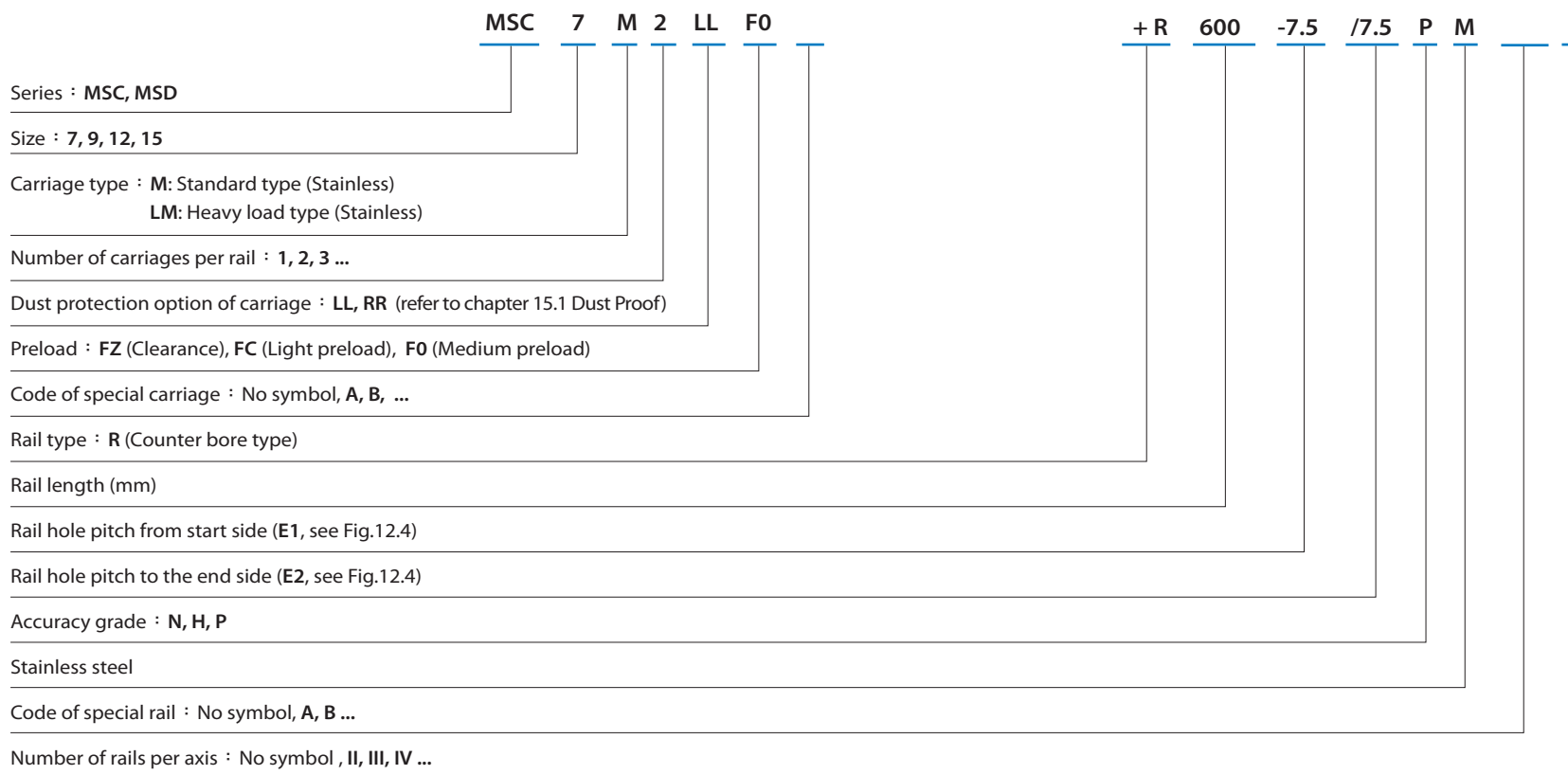

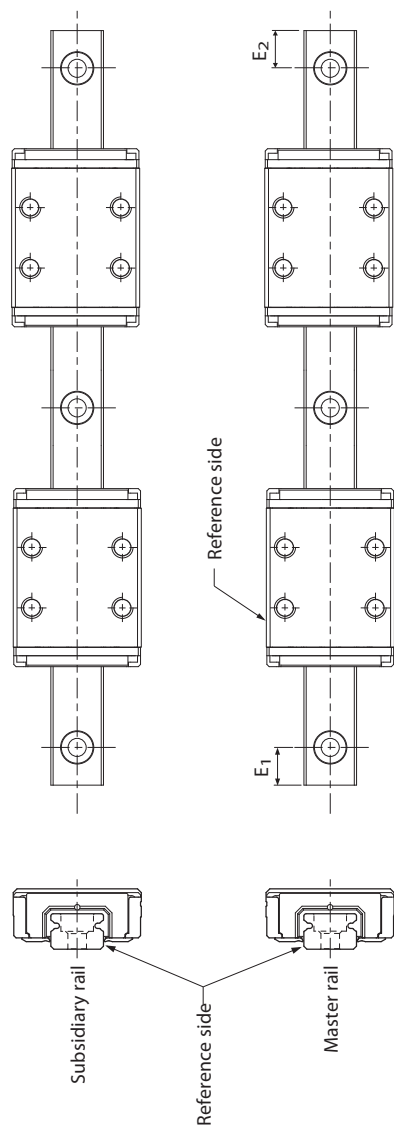

Fig 12.4

(2) Interchangeable Type

Code of Carriage

Series : MSC, MSD	MSC	7	M	LL	FZ	N
Size : 7, 9, 12, 15						
Carriage type : M: Standard type (Stainless) LM: Heavy load type (Stainless)						
Dust protection option of carriage : LL, RR (refer to chapter 15.1 Dust Proof)						
Preload : FZ (Clearance) FC (Light preload), F0 (Medium preload)						
Accuracy grade : N, H						
Code of special carriage : No symbol, A, B, C, D...						

Code of Rail

Series : MSC, MSD	MSC	7	R	600	-7.5	/7.5	N	M
Size : 7, 9, 12, 15								
Rail type : R (Counter bore type)								
Rail length (mm)								
Rail hole pitch from start side (E1, see Fig.12.4)								
Rail hole pitch to the end side (E2, see Fig.12.4)								
Accuracy grade : N, H								
Stainless steel								
Code of special rail : No symbol, A, B ...								

F. Accuracy Grade

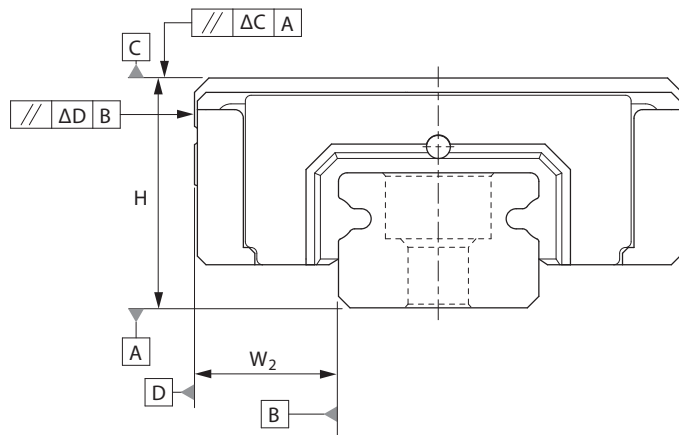

Table 1 Running Parallelism

Rail length (mm)		Running Parallelism Values(μm)		
Above	Or less	N	H	P
-	40	8	4	1
40	70	10	4	1
70	100	11	4	2
100	130	12	5	2
130	160	13	6	2
160	190	14	7	2
190	220	15	7	3
220	250	16	8	3
250	280	17	8	3

Rail length (mm)		Running Parallelism Values(μm)		
Above	Or less	N	H	P
280	310	17	9	3
310	340	18	9	3
340	370	18	10	3
370	400	19	10	3
400	430	20	11	4
430	460	20	12	4
460	490	21	12	4
490	520	21	12	4
520	550	22	12	4
550	580	22	13	4
580	610	22	13	4
610	640	22	13	4
640	670	23	13	4
670	700	23	13	5
700	730	23	14	5
730	760	23	14	5
760	790	23	14	5
790	820	23	14	5
820	850	24	14	5
850	880	24	15	5
880	910	24	15	5
910	940	24	15	5
940	970	24	15	5
970	1000	25	16	5

A Non-Interchangeable Type

Model No.	Item	Accuracy Grade		
		Normal N	High H	Precision P
7 9 12 15	Tolerance for height H	±0.04	±0.02	±0.01
	Height difference ΔH	0.03	0.015	0.007
	Tolerance for distance W_2	±0.04	±0.025	±0.015
	Difference in distance $W_2(\Delta W_2)$	0.03	0.02	0.01
	Running parallelism of surface C with surface A	ΔC (see the table 1)		
	Running parallelism of surface D with surface B	ΔD (see the table 1)		

B Interchangeable Type

Model No.	Item	Accuracy Grade		
		Normal N	High H	
7 9 12 15	Tolerance for height H	±0.04	±0.02	
	Tolerance for distance W_2	±0.04	±0.025	
	Paired single-rail	Height difference (ΔH)	0.03	0.015
		Difference in distance $W_2(\Delta W_2)$	0.03	0.02
	Paired multiple-rail height difference (ΔH)	0.07	0.04	
	Running parallelism of surface C with surface A	ΔC (see the table 1)		
	Running parallelism of surface D with surface B	ΔD (see the table 1)		

G. Preload Grade

Series	Preload grade		
	Clearance (FZ)	Light preload (FC)	Medium preload (F0)
MSC7	Clearance 4~10 μ m	Clearance 2 μ m~0.01C	0.01~0.02C
MSC9			
MSC12			
MSC15			
MSC7L	Clearance 4~10 μ m	Clearance 2 μ m~0.01C	0.01~0.02C
MSC9L			
MSC12L			
MSC15L			
MSD7	Clearance 4~10 μ m	Clearance 2 μ m~0.01C	0.01~0.02C
MSD9			
MSD12			
MSD15			
MSD7L	Clearance 4~10 μ m	Clearance 2 μ m~0.01C	0.01~0.02C
MSD9L			
MSD12L			
MSD15L			

Note: C is basic dynamic load rating in above table. Refer to the specification of products, please.

H. The Shoulder Height and Corner Radius for Installation

MSC series

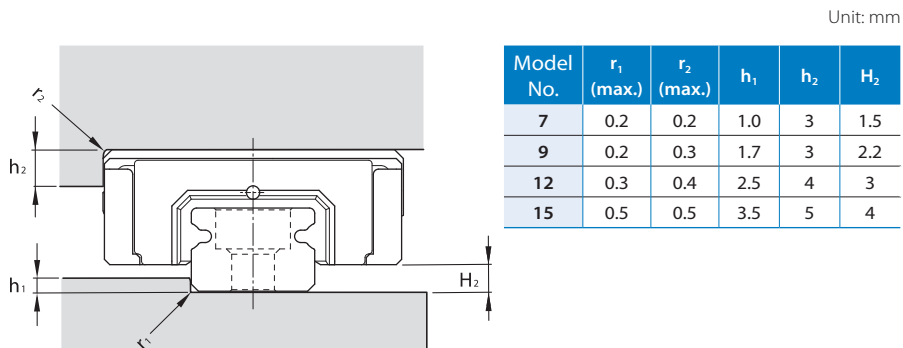

MSD series

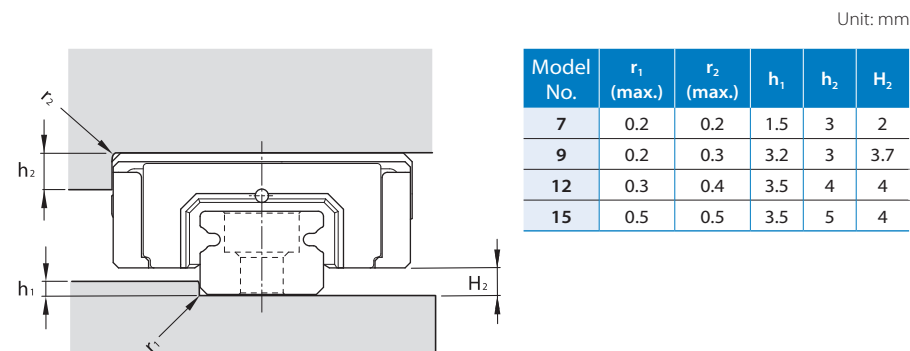

Unit: mm

I. Dimensional Tolerance of Mounting Surface

MSC / MSD Series

The tolerances of parallelism between two axes are shown as below.

The parallel deviation between two axes (e₁)

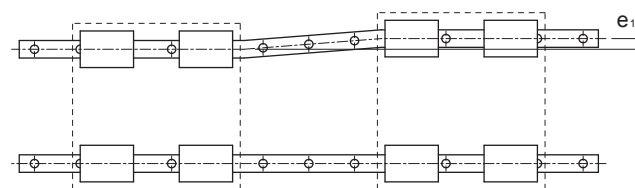

Unit: μm

Model No.	Preload Grade		
	FZ	FC	F0
MSC 7 MSD7	12	3	3
MSC 9 MSD9	15	4	3
MSC 12 MSD12	20	9	5
MSC 15 MSD15	25	10	6

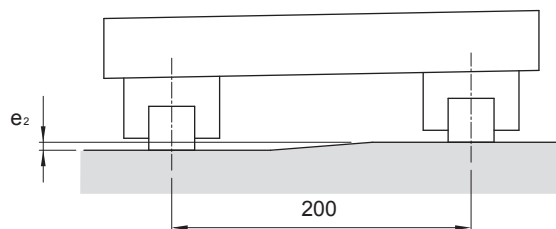
Level difference between two axes (e_2)Unit: μm

Model No.	Preload Grade		
	FZ	FC	F0
MSC 7 MSD7	25	25	6
MSC 9 MSD9	35	35	6
MSC 12 MSD12	50	50	12
MSC 15 MSD15	60	60	20

Note: The permissible values in table are applicable when the span is 200mm wide.

J. Rail Maximum Length and Standrad

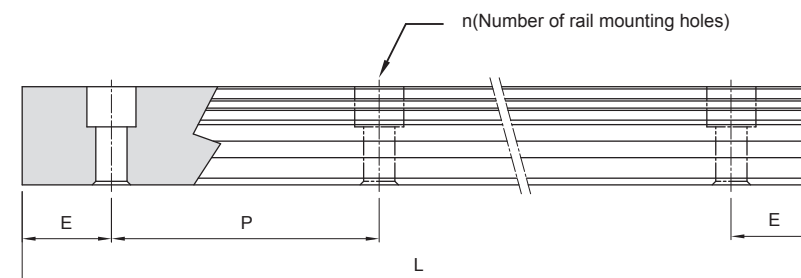

$$L = (n-1) \times P + 2 \times E$$

L: Total Length of rail (mm)

n: Nuber of mounting holes

P: Distance between any two holes (mm)

E: Distance from the center of the last hole to the edge (mm)

Unit: μm

Model No.	Standard Pitch (P)	Standard ($E_{\text{std.}}$)	Standard (maximum) ($L_0 \text{ max.}$)	
MSC	7	15	5	1000
	9	20	7.5	1000
	12	25	10	1000 (2000)
	15	40	15	1000 (2000)
MSD	7	30	10	1000 (2000)
	9	30	10	1000 (2000)
	12	40	15	1000 (2000)
	15	40	15	1000 (2000)

Dimensions of MSC-M / MSC-LM

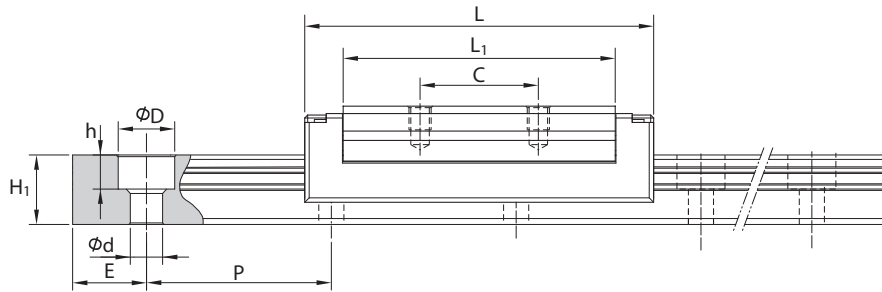

Unit: mm

Model No.	External dimension					Carriage dimension					
	Height H	Width W	Length L	W ₂	H ₂	B	C	S×l	L ₁	T	G
MSC 7 M MSC 7 LM	8	17	23.6 33.1	5	1.5	12	8 13	M2×2.5	18.4 27.9	3.5	∅0.8
MSC 9 M MSC 9 LM	10	20	31.1 41.3	5.5	2.2	15	10 16	M3×3	25.8 36	4.5	∅1
MSC 12 M MSC 12 LM	13	27	34.6 47.6	7.5	3	20	15 20	M3×3.6	28 41	6	∅1.5
MSC 15 M MSC 15 LM	16	32	43.5 60.5	8.5	4	25	20 25	M3×4.2	36.1 53.1	7	G-M3

Note: The basic dynamic load rating C of ball type is based on the 50 km for nominal life. The conversion between C for 50 km and C₁₀₀ for 100 km is C=1.26×C₁₀₀.

Note*: Single: Single carriage/ Double: Double carriages closely contacting with each other.

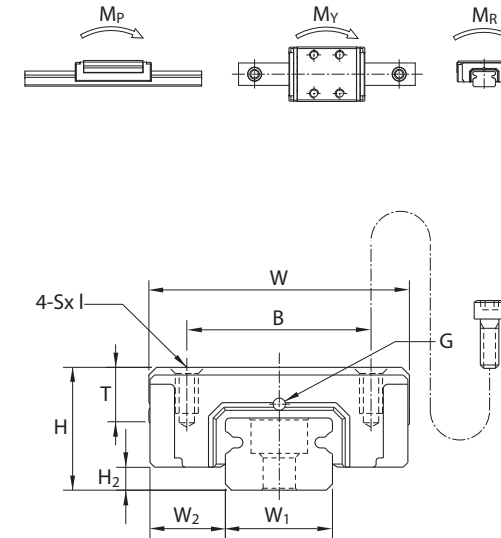

Unit: mm

Model No.	Rail dimension					Basic load rating		Static moment rating				Weight			
	Width W ₁	Height H ₁	Pitch P	E std.	D×h×d	Dynamic C	Static C ₀	M _p		M _y		M _r	Carriage g	Rail kg/m	
								Single	Double*	Single*	Double*				
MSC 7 M MSC 7 LM	7	0 -0.05	4.7	15	5	4.2×2.3×2.4	0.94 1.36	1.28 2.24	2.6 7.4	15.33 37.92	2.6 7.4	15.33 37.92	4.7 8.3	13 18	0.22
MSC 9 M MSC 9 LM	9	0 -0.05	5.5	20	7.5	6×3.3×3.5	1.71 2.52	2.24 3.92	6.1 17.4	33.46 84.63	6.1 17.4	33.46 84.63	10.8 18.8	29 39	0.33
MSC 12 M MSC 12 LM	12	0 -0.05	7.5	25	10	6×4.5×3.5	2.62 3.77	3.52 5.72	11.4 28.3	63.96 141.52	11.4 28.3	63.96 141.52	22.2 36.0	40 60	0.63
MSC 15 M MSC 15 LM	15	0 -0.05	9.5	40	15	6×4.5×3.5	4.52 6.47	5.70 9.26	24.7 61.0	132.17 295.87	24.7 61.0	132.17 295.87	44.4 72.2	71 100	1.02

Dimensions of MSD-M / MSD-LM

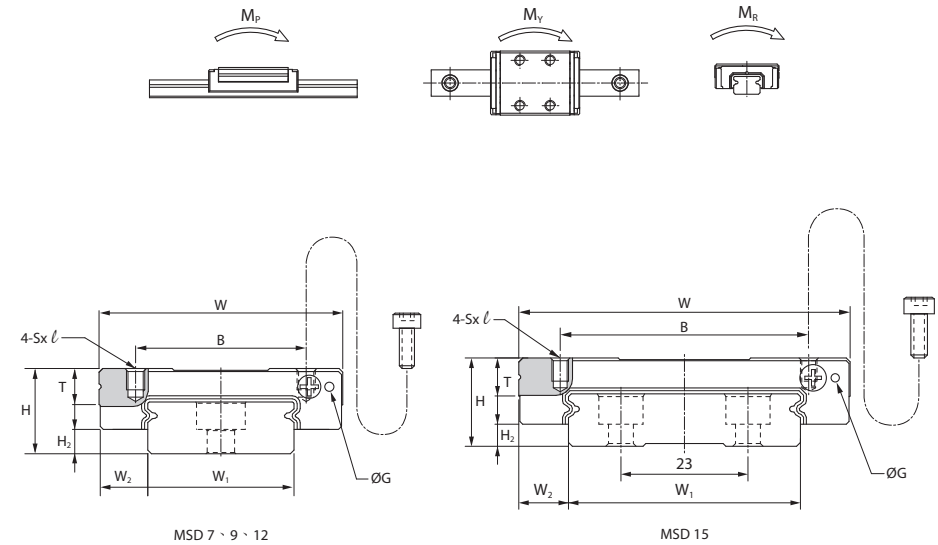
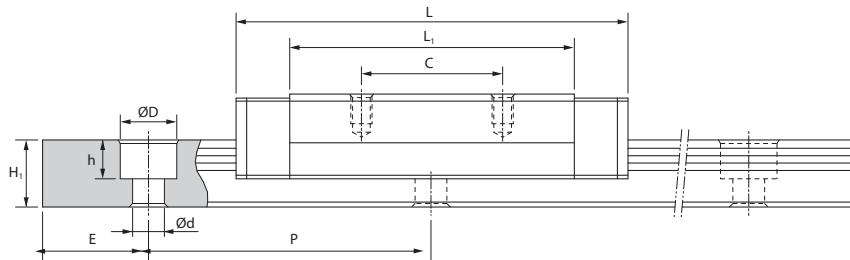

Unit: mm

Model No.	External dimension					Carriage dimension					
	Height H	Width W	Length L	W ₂	H ₂	B	C	S × l	L ₁	T	G
MSD 7 M MSD 7 LM	9	25	30.8 40.5	5.5	2	19	10 19	M3×3	20.6 30.3	3.9	Ø1.5
MSD 9 M MSD 9 LM	12	30	38.7 50.7	6	3.7	21 23	12 24	M3×3	27.1 39.1	5	Ø1.5
MSD 12 M MSD 12 LM	14	40	44.5 60	8	4	28	15 28	M3×4	31.0 46.5	6	Ø1.5
MSD 15 M MSD 15 LM	16	60	55.5 74.5	9	4	45	20 35	M4×4.5	40.3 59.3	7	Ø1.5

Note: The basic dynamic load rating C of ball type is based on the 50 km for nominal life. The conversion between C for 50 km and C100 for 100 km is $C=1.26 \times C100$.

Note*: Single: Single carriage/ Double: Double carriages closely contacting with each other.

Unit: mm

Model No.	Rail dimension					Basic load rating		Static moment rating				Weight			
	Width W ₁	Height H ₁	Pitch P	E std.	D × h × d	Dynamic C	Static C ₀	M _x N-m		M _y N-m		M _r N-m	Carriage g	Rail kg/m	
								Single*	Double*	Single*	Double*				
MSD 7 M MSD 7 LM	14	0 -0.05	5.2	30	10	6×3.2×3.5	1.51 2.04	2.46 3.79	6.6 17.5	39.0 84.0	6.6 17.5	39.0 84.0	17.7 27.3	23 31	0.55
MSD 9 M MSD 9 LM	18	0 -0.05	7	30	10	6×4.5×3.5	2.79 3.64	4.37 6.39	15.6 33.8	90.3 175.2	15.6 33.8	90.3 175.2	40.7 59.5	41 57	0.96
MSD 12 M MSD 12 LM	24	0 -0.05	8.5	40	15	8×4.5×4.5	4.05 5.28	6.20 9.06	26.3 57.0	151.5 294.4	26.3 57.0	151.5 294.4	76.3 116.6	70 101	1.55
MSD 15 M MSD 15 LM	42	0 -0.05	9.5	40	15	8×4.5×4.5	7.08 9.40	10.18 15.26	62.5 135.2	301.4 616.1	62.5 135.2	301.4 616.1	216.9 325.3	126 150	2.99

12.5 Ball Chain Type, SME Series

A. Construction

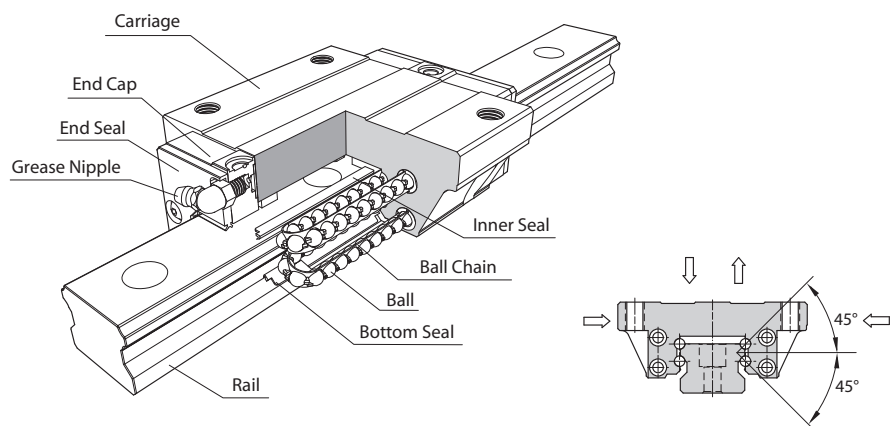

B. Characteristics

The ball chain type linear guideway, SME series, equip with the patent of ball chain design can make the movement smooth and stability, especially suit for the requests of high speed, high accuracy.

The Optimization Design of Four Directional Load

Through the structure stress analysis, SME series have four trains of balls are designed to a circular contact angle of 45° and the section design for high rigidity. Except for bearing heavier loads in radial, reversed radial and lateral directions, a sufficient preload can be achieved to increase rigidity, and this makes it suitable for any kind of installation.

Self Alignment Capability

The self adjustment is performed spontaneously as the design of face-face (DF) circular arc groove. Therefore, the installation error could be compensated even under a preload, and which results in precise and smooth linear motion.

Ball Chain Design, Smooth Movement

The concise and smooth design of circulating system with strengthened synthetic resin accessories and cooperating with the ball chain, these can avoid interference between balls and make the balls more stability during passing in and out the load district. Besides, the ball chain can keep the ball move in a line and improve the movement most smooth substantially.

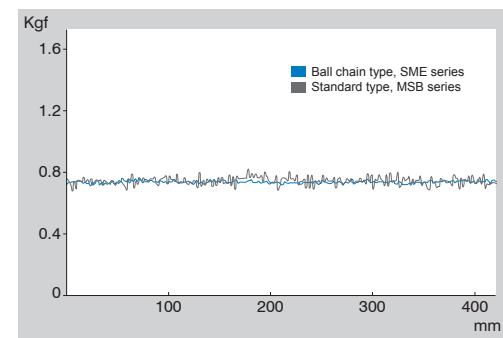

Rolling resistance test

Low Noise, Good Lubricant Effect

The ball chain design avoids interference between balls, lowers the operating noise, and can keep the lubricant between the balls and ball chain effectively. Moreover, improve the movement smooth and service life of the whole, can meet high accuracy, high reliability and smooth and stability.

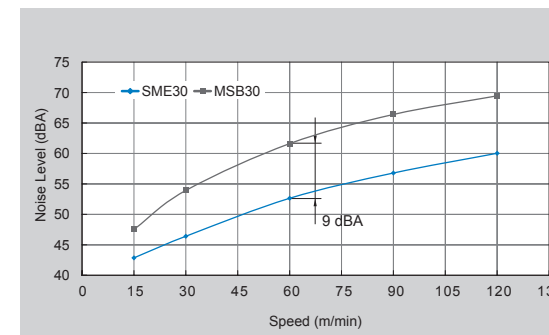

Noise level comparison test

C. Carriage Type

Heavy Load

SME-EA Type

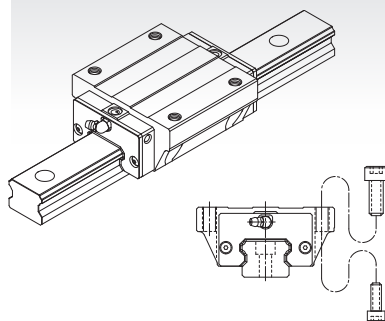

This type offers the installation either from top or bottom side of carriage.

SME-EB Type

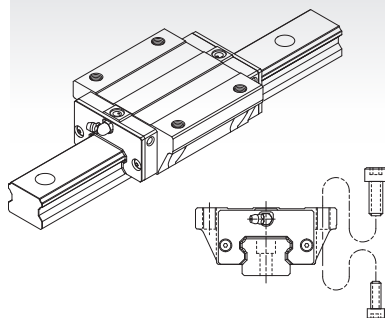

All dimensions are same as SME-EA except the mounting hole dimensions of carriage are different and the height is lower, which do not change the basic loading rating.

SME-SA Type

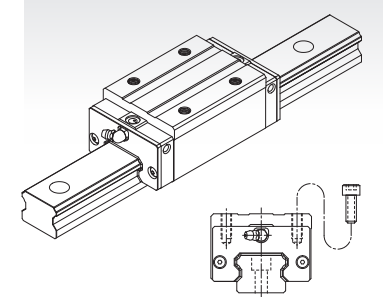

Square type with smaller width and can be installed from top side of carriage.

SME-SB / SME-SV Type

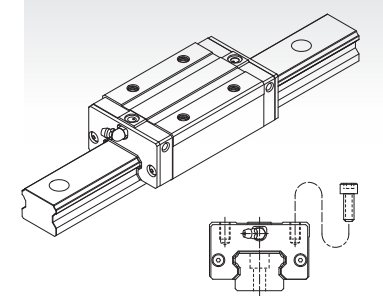

All dimensions are same as SME-SA except the mounting hole dimensions of carriage are different and the height is lower, which do not change the basic loading rating.

Ultra Heavy Load

SME-LEA Type

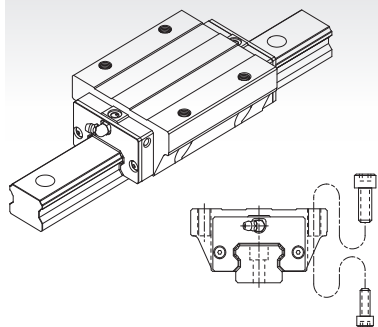

All dimensions are same as SME-EA except the length is longer, which makes it more rigid.

SME-LEB Type

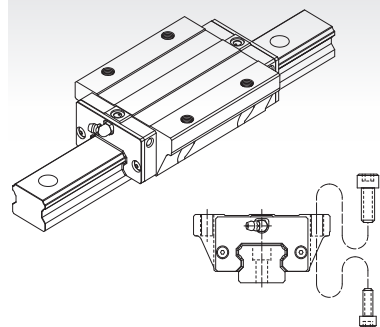

All dimensions are same as SME-EB except the length is longer, which makes it more rigid.

SME-LSA Type

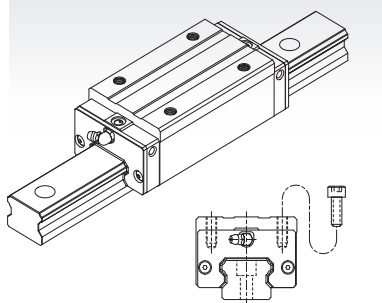

All dimensions are same as SME-SA except the length is longer, which makes it more rigid.

SME-LSB / SME-LSV Type

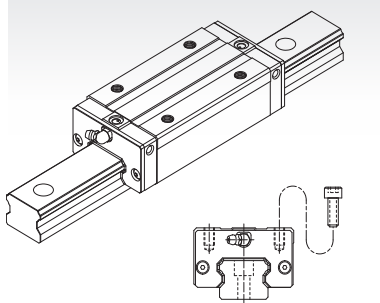

All dimensions are same as SME-SB and SME-SV except the length is longer, which makes it more rigid.

D. Rail Type

Counter bore(R type)

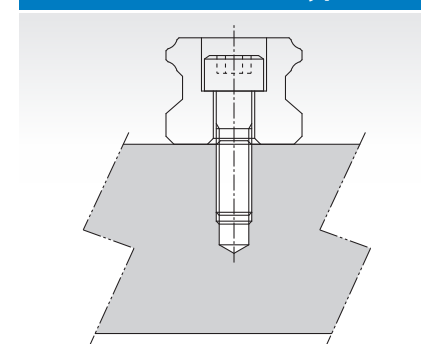

Tapped-Hole(T type)

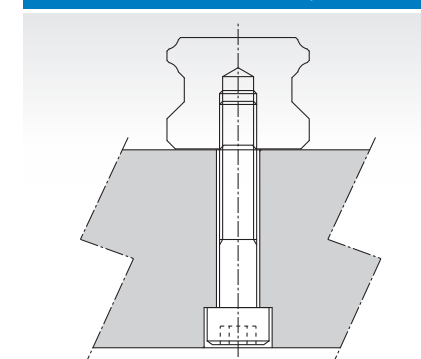

E. Description of Specification

(1) Non-interchangeable Type

	SME	25	EA	2	SS	F0		+R	1000	-20	/20	P		II
Series : SME														
Size : 15, 20, 25, 30, 35, 45														
Carriage type : (1) Heavy load														
EA : Flange type, mounting either from top or bottom														
EB : Compact flange type, mounting either from top or bottom														
SA : Square type														
SB/SV : Compact square type														
(2) Ultra heavy load														
LEA : Flange type, mounting either from top or bottom														
LEB : Compact flange type, mounting either from top or bottom														
LSA : Square type														
LSB/LSV : Compact square type														
Number of carriages per rail : 1, 2, 3 ...														
Dust protection option of carriage : No symbol, UU, SS, ZZ, DD, KK (refer to chapter 15.1 Dust Proof)														
Preload : FC (Light Preload), F0 (Medium preload), F1 (Heavy preload)														
Code of special carriage : No symbol, A, B, ...														
Rail type : R (Counter-bore type), T (Tapped hole type)														
Rail length (mm)														
Rail hole pitch from start side (E1, see Fig.12.5)														
Rail hole pitch to the end side (E2, see Fig.12.5)														
Accuracy grade : N, H, P, SP, UP														
Code of special rail : No symbol, A, B ...														
Dust protection option of rail : No symbol, /CC, /MC, /MD ... (refer to chapter 15.1 Code of contamination fro Rail)														
Number of rails per axis : No symbol, II, III, IV ...														

Fig. 12.5

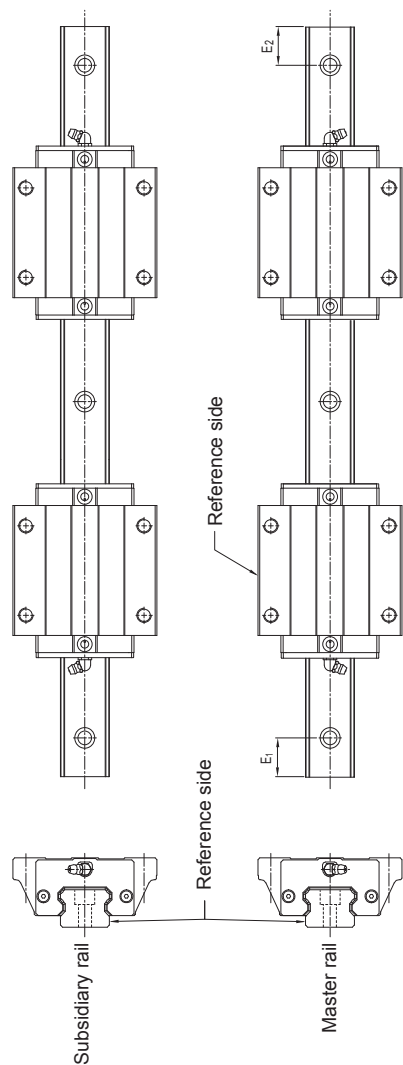

(2) Interchangeable Type

Code of Carriage

Series : **SME**

Size : **15, 20, 25, 30, 35, 45**

Carriage type : (1) Heavy load

EA : Flange type, mounting either from top or bottom

EB : Compact flange type, mounting either from top or bottom

SA : Square type

SB/SV : Compact square type

(2) Ultra heavy load

LEA : Flange type, mounting either from top or bottom

LEB : Compact flange type, mounting either from top or bottom

LSA : Square type

LSB/LSV : Compact square type

Dust protection option of carriage : No symbol, **UU, SS, ZZ, DD, KK** (refer to chapter 15.1 Dust Proof)

Preload : **FC** (Light Preload), **F0** (Medium preload)

Accuracy grade : **N, H, P**

Code of special carriage : No symbol, **A, B, ...**

SME 25 EA SS FC H

Code of Rail

Series : **SME**

Size : **15, 20, 25, 30, 35, 45**

Rail type : **R** (Counter-bore type), **T** (Tapped hole type)

Rail length (mm)

Rail hole pitch from start side (**E1**, see Fig.12.5)

Rail hole pitch to the end side (**E2**, see Fig.12.5)

Accuracy grade : **N, H, P**

Code of special rail : No symbol, **A, B ...**

Dust protection option of rail : No symbol, **/CC, /MC, /MD ...** (refer to chapter 15.1 Code of contamination fro Rail)

SME 25 R 1000 -20 /20 H

F. Accuracy Grade

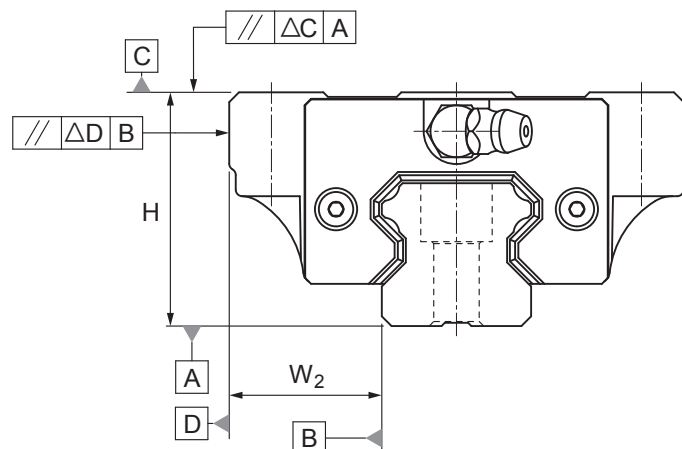

Table 1 Running Parallelism

Rail length (mm)		Running Parallelism Values(μm)				
Above	Or less	N	H	P	SP	UP
0	315	9	6	3	2	1.5
315	400	11	8	4	2	1.5
400	500	13	9	5	2	1.5
500	630	16	11	6	2.5	1.5
630	800	18	12	7	3	2
800	1000	20	14	8	4	2
1000	1250	22	16	10	5	2.5
1250	1600	25	18	11	6	3
1600	2000	28	20	13	7	3.5
2000	2500	30	22	15	8	4
2500	3000	32	24	16	9	4.5
3000	3500	33	25	17	11	5
3500	4000	34	26	18	12	6

A Non-Interchangeable Type

Model No.	Item	Accuracy Grade				
		Normal N	High H	Precision P	Super Precision SP	Ultra Precision UP
15 20	Tolerance for height H	±0.1	±0.03	0 -0.03	0 -0.015	0 -0.008
	Height difference ΔH	0.02	0.01	0.006	0.004	0.003
	Tolerance for distance W ₂	±0.1	±0.03	0 -0.03	0 -0.015	0 -0.008
	Difference in distance W ₂ (ΔW ₂)	0.02	0.01	0.006	0.004	0.003
	Running parallelism of surface C with surface A	ΔC (see the table 1)				
	Running parallelism of surface D with surface B	ΔD (see the table 1)				
25 30 35	Tolerance for height H	±0.1	±0.04	0 -0.04	0 -0.02	0 -0.01
	Height difference ΔH	0.02	0.015	0.007	0.005	0.003
	Tolerance for distance W ₂	±0.1	±0.04	0 -0.04	0 -0.02	0 -0.01
	Difference in distance W ₂ (ΔW ₂)	0.03	0.015	0.007	0.005	0.003
	Running parallelism of surface C with surface A	ΔC (see the table 1)				
	Running parallelism of surface D with surface B	ΔD (see the table 1)				
45	Tolerance for height H	±0.1	±0.05	0 -0.05	0 -0.03	0 -0.02
	Height difference ΔH	0.03	0.015	0.007	0.005	0.003
	Tolerance for distance W ₂	±0.1	±0.05	0 -0.05	0 -0.03	0 -0.02
	Difference in distance W ₂ (ΔW ₂)	0.03	0.02	0.01	0.007	0.005
	Running parallelism of surface C with surface A	ΔC (see the table 1)				
	Running parallelism of surface D with surface B	ΔD (see the table 1)				

B Interchangeable Type

Model No.	Item	Accuracy Grade		
		Normal N	High H	Precision P
15 20	Tolerance for height H	±0.1	±0.03	0 -0.03
	Height difference ΔH	0.02	0.01	0.006
	Tolerance for distance W ₂	±0.1	±0.03	0 -0.03
	Difference in distance W ₂ (ΔW ₂)	0.02	0.01	0.006
	Running parallelism of surface C with surface A	ΔC (see the table 1)		
	Running parallelism of surface D with surface B	ΔD (see the table 1)		
25 30 35	Tolerance for height H	±0.1	±0.04	0 -0.04
	Height difference ΔH	0.02	0.015	0.007
	Tolerance for distance W ₂	±0.1	±0.04	0 -0.04
	Difference in distance W ₂ (ΔW ₂)	0.03	0.015	0.007
	Running parallelism of surface C with surface A	ΔC (see the table 1)		
	Running parallelism of surface D with surface B	ΔD (see the table 1)		
45	Tolerance for height H	±0.1	±0.05	0 -0.05
	Height difference ΔH	0.03	0.015	0.007
	Tolerance for distance W ₂	±0.1	±0.05	0 -0.05
	Difference in distance W ₂ (ΔW ₂)	0.03	0.02	0.01
	Running parallelism of surface C with surface A	ΔC (see the table 1)		
	Running parallelism of surface D with surface B	ΔD (see the table 1)		

G. Preload Grade

Series	Preload grade		
	Light preload (FC)	Medium preload (F0)	Heavy preload (F1)
SME15	0.01~0.03C	0.04~0.06C	-
SME20			
SME25			
SME30			
SME35			
SME45			
SME15L	0.01~0.03C	0.04~0.06C	0.07~0.09C
SME20L			
SME25L			
SME30L			
SME35L			
SME45L			

Note: C is basic dynamic load rating in above table. Refer to the specification of products, please.

H. The Shoulder Height and Corner Radius for Installation

SME series

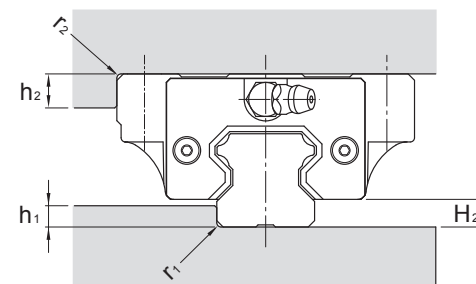

Unit: mm

Model No.	r ₁ (max.)	r ₂ (max.)	h ₁	h ₂	H ₂
15	0.5	0.5	2.5	5	3.5
20	0.5	0.5	3.5	5	4.7
25	1	1	5	6	5.8
30	1	1	5	7	7.5
35	1	1	6	8	8
45	1	1	8	8	10

I. Dimensional Tolerance of Mounting Surface

SME with the self alignment capability, the minor dimensional error in mounting surface could be compensated and achieves smooth linear motion. The tolerances of parallelism between two axes are shown as below.

The parallel deviation between two axes (e_1)

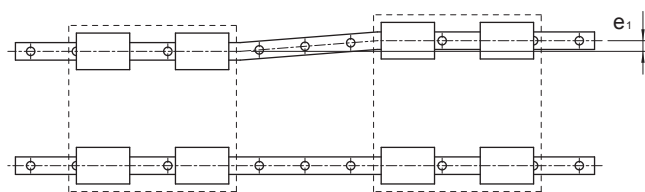

Unit: μm

Model No.	Preload Grade		
	FC	F0	F1
15	25	18	-
20	25	20	18
25	30	22	20
30	40	30	27
35	50	35	30
45	60	40	35

Level difference between two axes (e_2)

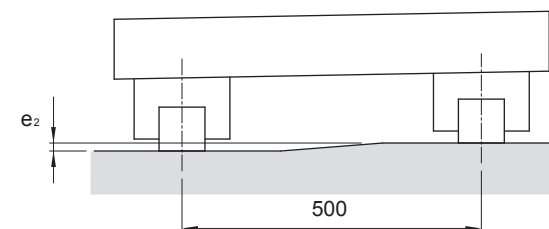

Unit: μm

Model No.	Preload Grade		
	FC	F0	F1
15	130	85	-
20	130	85	50
25	130	85	70
30	170	110	90
35	210	150	120
45	250	170	140

Note: The permissible values in table are applicable when the span is 500mm wide.

J. Rail Maximum Length and Standrad

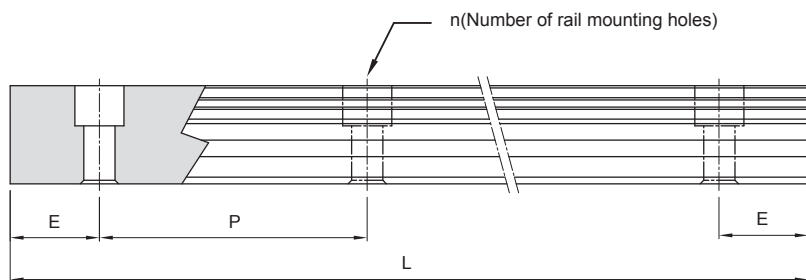

$$L=(n-1) \times P+2 \times E$$

L: Total Length of rail (mm)

n: Nuber of mounting holes

P: Distance between any two holes (mm)

E: Distance from the center of the last hole to the edge (mm)

Unit: mm

Model No.	Standard Pitch (P)	Standard (E _{std.})	Minimum (E _{min.})	Max (L _o max.)
SME 15	60	20	5	4000
SME 20	60	20	6	4000
SME 25	60	20	7	4000
SME 30	80	20	8	4000
SME 35	80	20	8	4000
SME 45	105	22.5	11	4000

K. Tapped-hole Rail Dimensions

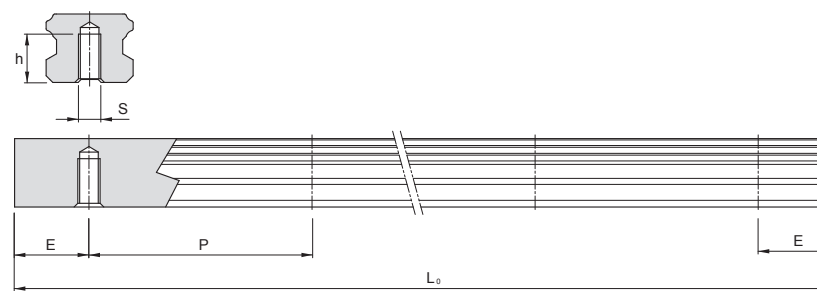

Rail Model	S	h(mm)
SME 15 T	M5	8
SME 20 T	M6	10
SME 25 T	M6	12
SME 30 T	M8	15
SME 35 T	M8	17
SME 45 T	M12	24

Dimensions of SME-EA / SME-LEA

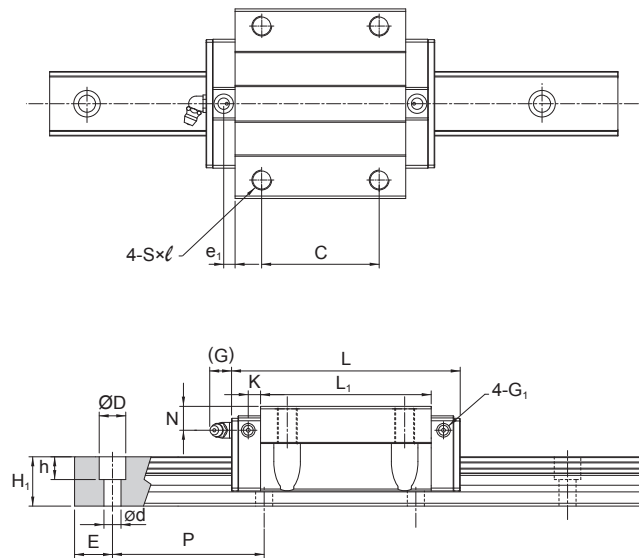

Unit: mm

Model No.	External dimension				Carriage dimension													Grease Nipple
	Height H	Width W	Length L	W ₂	H ₂	B	C	S × l	L ₁	T	T ₁	N	G	K	e ₁	G ₁		
SME 15 EA SME 15 LEA	24	47	64.4 79.4	16	3.5	38	30	M5×8	48 63	5.5	8	5	5.5	2.7	-	M4	G-M4	
SME 20 EA SME 20 LEA	30	63	78.5 97.5	21.5	4.7	53	40	M6×10	58.3 77.3	7	10	8	12	3.7	-	M4	G-M6	
SME 25 EA SME 25 LEA	36	70	92 109	23.5	5.8	57	45	M8×13	71 88	7	13	10	12	4.7	-	M4	G-M6	
SME 30 EA SME 30 LEA	42	90	107.6 132.6	31	7.5	72	52	M10×15	80 105	12	15	8	12	4.5	5.4	M6	G-M6	
SME 35 EA SME 35 LEA	48	100	120.6 150.6	33	8	82	62	M10×15	90 120	12	15	8	12	5.4	6	M6	G-M6	
SME 45 EA SME 45 LEA	60	120	140 174.5	37.5	10	100	80	M12×18	106 140.5	12	18	10	13.5	8.5	6.1	M6	G-PT 1/8	

Note: The basic dynamic load rating C of ball type is based on the 50 km for nominal life. The conversion between C for 50 km and C₁₀₀ for 100 km is C=1.26 × C₁₀₀.

Note*: Single: Single carriage/ Double: Double carriages closely contacting with each other.

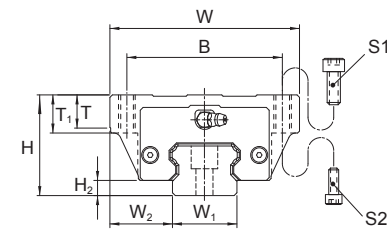
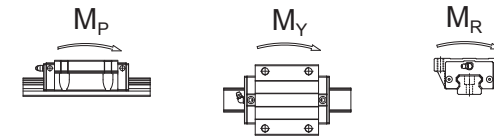

Model No.	Bolt Size	
	S ₁	S ₂
SME 15	M5	M4
SME 20	M6	M5
SME 25	M8	M6
SME 30	M10	M8
SME 35	M10	M8
SME 45	M12	M10

Unit: mm

Model No.	Rail dimension					Basic load rating		Static moment rating				Weight		
	Width W ₁	Height H ₁	Pitch P	E std.	D × h × d	Dynamic C kN	Static C ₀ kN	M _p kN-m		M _y kN-m		M _R kN-m	Carriage kg	Rail kg/m
								Single*	Double*	Single*	Double*			
SME 15 EA SME 15 LEA	15	13	60	20	7.5×5.8×4.5	12.5 15.4	20.2 27.5	0.14 0.25	0.69 1.15	0.14 0.25	0.69 1.15	0.16 0.21	0.22 0.29	1.4
SME 20 EA SME 20 LEA	20	15.5	60	20	9.5×8.5×6	20.4 25.3	32.1 43.6	0.27 0.49	1.34 2.24	0.27 0.49	1.34 2.24	0.33 0.44	0.42 0.62	2.3
SME 25 EA SME 25 LEA	23	18	60	20	11×9×7	28.3 33.0	44.3 56.1	0.45 0.71	2.14 3.20	0.45 0.71	2.14 3.20	0.52 0.66	0.67 0.89	3.2
SME 30 EA SME 30 LEA	28	23	80	20	14×12×9	39.4 47.0	59.5 76.5	0.68 1.11	3.37 5.32	0.68 1.11	3.37 5.32	0.83 1.07	1.18 154	4.5
SME 35 EA SME 35 LEA	34	26	80	20	14×12×9	54.7 67.6	81.0 109.9	1.07 1.92	5.25 8.75	1.07 1.92	5.25 8.75	1.41 1.91	1.74 2.28	6.2
SME 45 EA SME 45 LEA	45	32	105	22.5	20×17×14	72.7 90.0	105.8 143.6	1.61 2.88	7.82 13.08	1.61 2.88	7.82 13.08	2.41 3.27	3.22 4.21	10.5

Dimensions of SME-EB / SME-LEB

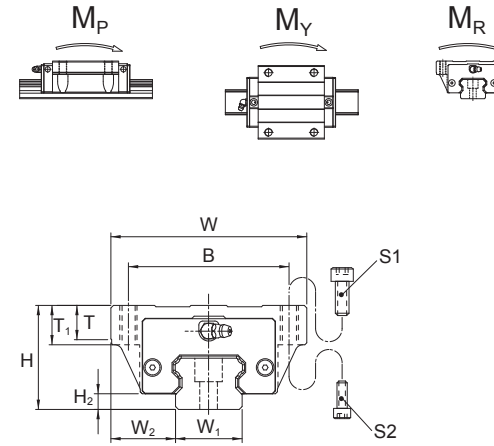
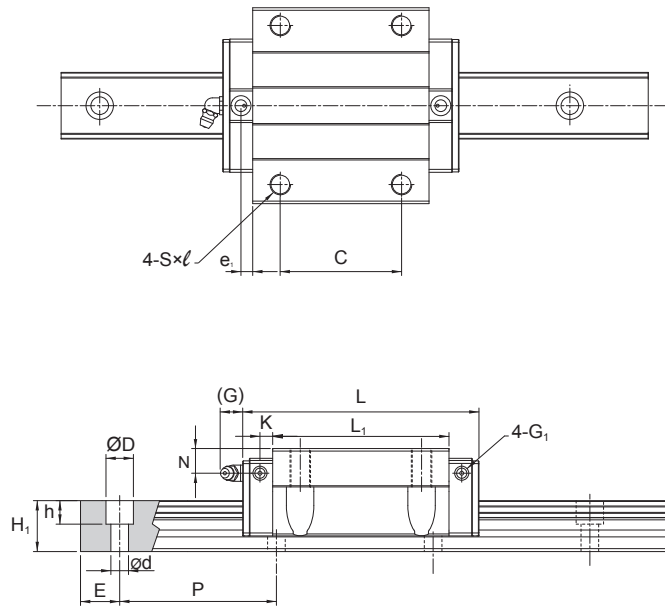

Model No.	Bolt Size	
	S ₁	S ₂
SME 15	M5	M4
SME 20	M6	M5
SME 25	M8	M6

Unit: mm

Model No.	External dimension				Carriage dimension												Grease Nipple
	Height H	Width W	Length L	W ₂	H ₂	B	C	S × l	L ₁	T	T ₁	N	G	K	e ₁	G ₁	
SME 15 EB SME 15 LEB	24	52	64.4 79.4	18.5	3.5	41	26 36	M5×8	48 63	5.5	8	5	5.5	2.7	-	M4	G-M4
SME 20 EB SME 20 LEB	28	59	78.5 97.5	19.5	4.7	49	32 45	M6×8	58.3 77.3	7.0	8	6.0	12	3.7	-	M4	G-M6
SME 25 EB SME 25 LEB	33	73	92 109	25	5.8	60	35 50	M8×10	71 88	7.0	10	7.0	12	4.7	-	M4	G-M6

Note: The basic dynamic load rating C of ball type is based on the 50 km for nominal life. The conversion between C for 50 km and C₁₀₀ for 100 km is C=1.26 × C₁₀₀.

Note*: Single: Single carriage/ Double: Double carriages closely contacting with each other.

Unit: mm

Model No.	Rail dimension					Basic load rating		Static moment rating				Weight		
	Width W ₁	Height H ₁	Pitch P	E std.	D × h × d	Dynamic C	Static C ₀	M _p		M _y		M _R	Carriage kg	Rail kg/m
								Single	Double*	Single	Double*			
SME 15 EB SME 15 LEB	15	13	60	20	7.5×5.8×4.5	12.5 15.4	20.2 27.5	0.14 0.25	0.69 1.15	0.14 0.25	0.69 1.15	0.16 0.21	0.21 0.27	1.4
SME 20 EB SME 20 LEB	20	15.5	60	20	9.5×8.5×6	20.4 25.3	32.1 43.6	0.27 0.49	1.34 2.24	0.27 0.49	1.34 2.24	0.33 0.44	0.39 0.55	2.3
SME 25 EB SME 25 LEB	23	18	60	20	11×9×7	28.3 33.0	44.3 56.1	0.45 0.71	2.14 3.20	0.45 0.71	2.14 3.20	0.52 0.66	0.42 0.65	3.2

Dimensions of SME-SA / SME-LSA

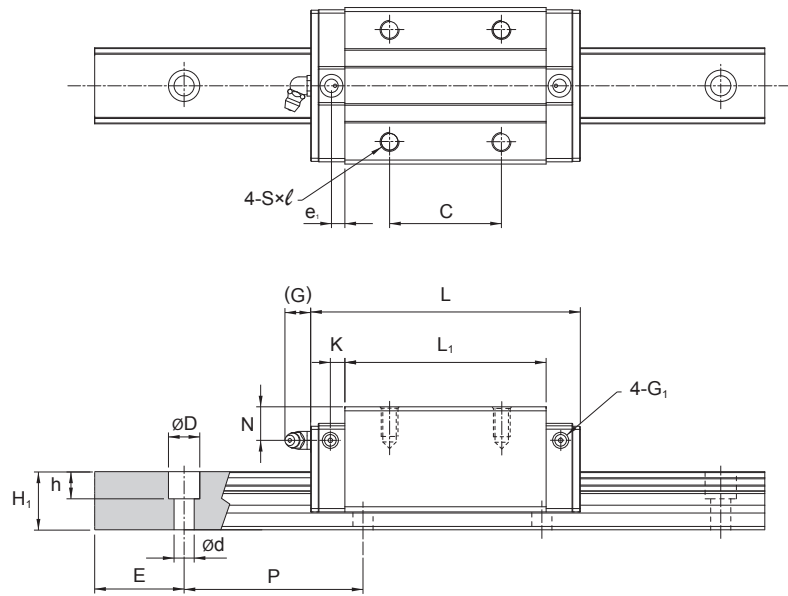

Unit: mm

Model No.	External dimension				Carriage dimension												Grease Nipple
	Height H	Width W	Length L	W_2	H_2	B	C	$S \times l$	L_1	T	N	G	K	e_1	G_1		
SME 15 SA SME 15 LSA	28	34	64.4 79.4	9.5	3.5	26	26	M4×7.5	48 63	6	9	5.5	2.7	-	M4	G-M4	
SME 20 SA SME 20 LSA	30	44	78.5 97.5	12	4.7	32	36 50	M5×7	58.3 77.3	6	8	12	3.7	-	M4	G-M6	
SME 25 SA SME 25 LSA	40	48	92 109	12.5	5.8	35	35 50	M6×12	71 88	8	14	12	4.7	-	M4	G-M6	
SME 30 SA SME 30 LSA	45	60	107.6 132.6	16	7.5	40	40 60	M8×12	80 105	8	11	12	4.5	5.4	M6	G-M6	
SME 35 SA SME 35 LSA	55	70	120.6 150.6	18	8	50	50 72	M8×14	90 120	11	15	12	5.4	6	M6	G-M6	
SME 45 SA SME 45 LSA	70	86	140 174.5	20.5	10	60	60 80	M10×20	106 140.5	16	20	13.5	8.5	6.1	M6	G-PT 1/8	

Note: The basic dynamic load rating C of ball type is based on the 50 km for nominal life. The conversion between C for 50 km and C_{100} for 100 km is $C=1.26 \times C_{100}$.

Note*: Single: Single carriage/ Double: Double carriages closely contacting with each other.

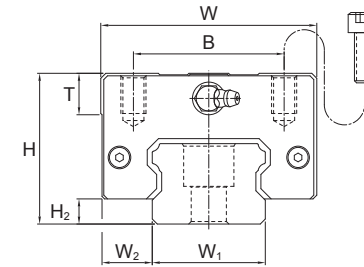
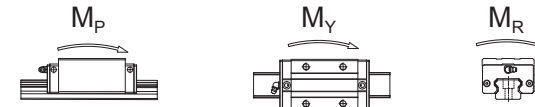

Unit: mm

Model No.	Rail dimension					Basic load rating		Static moment rating				Weight		
	Width W_1	Height H_1	Pitch P	E std.	$D \times h \times d$	Dynamic C kN	Static C_0 kN	M_p kN-m		M_y kN-m		M_r kN-m	Carriage kg	Rail kg/m
								Single*	Double*	Single*	Double*			
SME 15 SA SME 15 LSA	15	13	60	20	7.5×5.8×4.5	12.5 15.4	20.2 27.5	0.14 0.25	0.69 1.15	0.14 0.25	0.69 1.15	0.16 0.21	0.22 0.25	1.4
SME 20 SA SME 20 LSA	20	15.5	60	20	9.5×8.5×6	20.4 25.3	32.1 43.6	0.27 0.49	1.34 2.24	0.27 0.49	1.34 2.24	0.33 0.44	0.30 0.39	2.3
SME 25 SA SME 25 LSA	23	18	60	20	11×9×7	28.3 33.0	44.3 56.1	0.45 0.71	2.14 3.20	0.45 0.71	2.14 3.20	0.52 0.66	0.56 0.73	3.2
SME 30 SA SME 30 LSA	28	23	80	20	14×12×9	39.4 47.0	59.5 76.5	0.68 1.11	3.37 5.32	0.68 1.11	3.37 5.32	0.83 1.07	0.93 1.21	4.5
SME 35 SA SME 35 LSA	34	26	80	20	14×12×9	54.7 67.6	81.0 109.9	1.07 1.92	5.25 8.75	1.07 1.92	5.25 8.75	1.41 1.91	1.57 2.05	6.2
SME 45 SA SME 45 LSA	45	32	105	22.5	20×17×14	72.7 90.0	105.8 143.6	1.61 2.88	7.82 13.08	1.61 2.88	7.82 13.08	2.41 3.27	3.06 4.00	10.5

Dimensions of SME-SB / SME-LSB

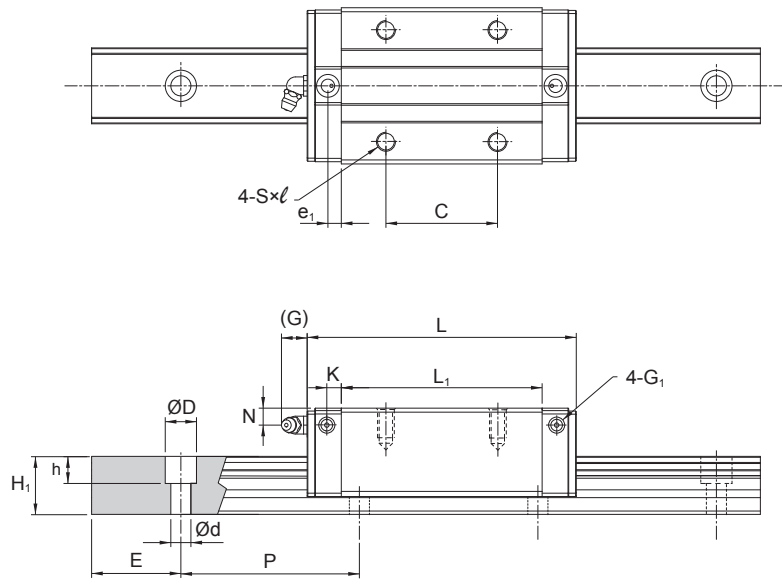

Unit: mm

Model No.	External dimension					Carriage dimension										Grease Nipple
	Height H	Width W	Length L	W_2	H_2	B	C	$S \times l$	L_1	T	N	G	K	e_1	G_1	
SME 15 SB SME 15 LSB	24	34	64.4 79.4	9.5	3.5	26	26 34	M4×5	48 63	6	5	5.5	2.7	-	M4	G-M4
SME 20 SB SME 20 LSB	28	42	78.5 97.5	11	4.7	32	32 45	M5×5.5	58.3 77.3	6	6	12	3.7	-	M4	G-M6
SME 25 SB SME 25 LSB	33	48	92 109	12.5	5.8	35	35 50	M6×7	71 88	8	7	12	4.7	-	M4	G-M6
SME 25 SV SME 25 LSV	36	48	92 109	12.5	5.8	35	35 50	M6×9	71 88	8	10	12	4.7	-	M4	G-M6
SME 30 SB SME 30 LSB	42	60	107.6 132.6	16	7.5	40	40 60	M8×10	80 105	8	8	12	4.5	5.4	M6	G-M6
SME 35 SB SME 35 LSB	48	70	120.6 150.6	18	8	50	50 72	M8×11	90 120	11	8	12	5.4	6	M6	G-M6
SME 45 SB SME 45 LSB	60	86	140 174.5	20.5	10	60	60 80	M10×16	106 140.5	16	10	13.5	8.5	6.1	M6	G-PT 1/8

Note: The basic dynamic load rating C of ball type is based on the 50 km for nominal life. The conversion between C for 50 km and C_{100} for 100 km is $C=1.26 \times C_{100}$.

Note*: Single: Single carriage/ Double: Double carriages closely contacting with each other.

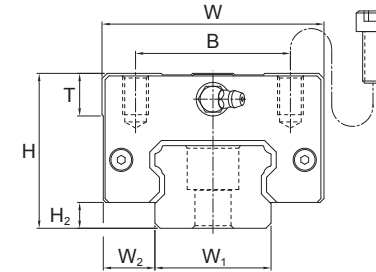
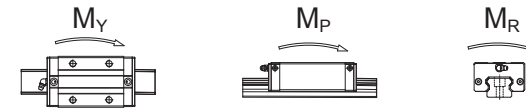

Unit: mm

Model No.	Rail dimension					Basic load rating		Static moment rating				Weight		
	Width W_1	Height H_1	Pitch P	E std.	$D \times h \times d$	Dynamic	Static	M_p		M_v		M_R	Carriage kg	Rail kg/m
						C kN	C_0 kN	Single* kN-m	Double* kN-m	Single* kN-m	Double* kN-m			
SME 15 SB SME 15 LSB	15	13	60	20	7.5×5.8×4.5	12.5 15.4	20.2 27.5	0.14 0.25	0.69 1.15	0.14 0.25	0.69 1.15	0.16 0.21	0.19 0.22	1.4
SME 20 SB SME 20 LSB	20	15.5	60	20	9.5×8.5×6	20.4 25.3	32.1 43.6	0.27 0.49	1.34 2.24	0.27 0.49	1.34 2.24	0.33 0.44	0.26 0.35	2.3
SME 25 SB SME 25 LSB	23	18	60	20	11×9×7	28.3 33.0	44.3 56.1	0.45 0.71	2.14 3.20	0.45 0.71	2.14 3.20	0.52 0.66	0.31 0.49	3.2
SME 25 SV SME 25 LSV	23	18	60	20	11×9×7	28.3 33.0	44.3 56.1	0.45 0.71	2.14 3.20	0.45 0.71	2.14 3.20	0.52 0.66	0.44 0.62	3.2
SME 30 SB SME 30 LSB	28	23	80	20	14×12×9	39.4 47.0	59.5 76.5	0.68 1.11	3.37 5.32	0.68 1.11	3.37 5.32	0.83 1.07	0.85 1.10	4.5
SME 35 SB SME 35 LSB	34	26	80	20	14×12×9	54.7 67.6	81.0 109.9	1.07 1.92	5.25 8.75	1.07 1.92	5.25 8.75	1.41 1.91	1.22 1.61	6.2
SME 45 SB SME 45 LSB	45	32	105	22.5	20×17×14	72.7 90.0	105.8 143.6	1.61 2.88	7.82 13.08	1.61 2.88	7.82 13.08	2.41 3.27	2.86 3.57	10.5

12.6 Roller Chain Type, SMR Series

A. Construction

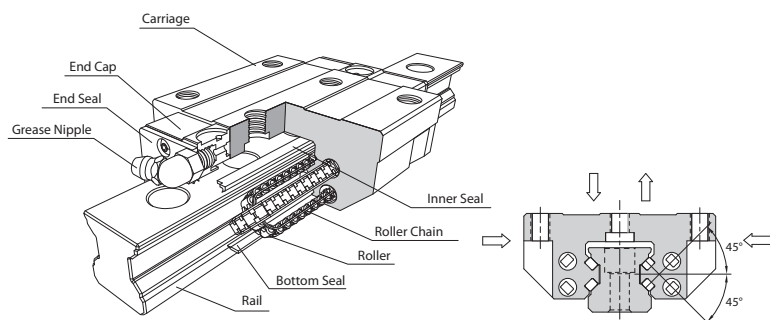

B. Characteristics

The roller chain type linear guideway, SMR series, equip with rollers instead of the ball, and therefore the SMR series can provide higher rigidity and loading than the normal type with the same size. Besides, the patent of roller chain design can make the movement smooth and stability, especially suit for the requests of high accuracy, heavy load and high rigidity.

Ultra Heavy Load

SMR linear guideway through rollers have a line contact with carriage and rail. Relative to the general type linear guideway through balls have a point contact; the SMR type linear guideway can offer lower elastic deformation while bearing the same load. Base on the rollers have the same outer diameter with balls, the roller can bear the heavier load. The excellent characteristics of high rigidity and ultra heavy load can suitable for the high accuracy application that heavy load is processed even more.

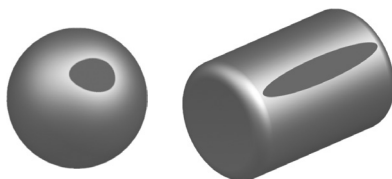

The Optimization Design of Four Directional Load

Through the structure stress analysis of finite element method, SMR series have four trains of rollers are designed to a contact angle of 45° and the section design for high rigidity. Except for bearing heavier loads in radial, reversed radial and lateral directions, a sufficient preload can be achieved to increase rigidity, and this makes it suitable for any kind of installation.

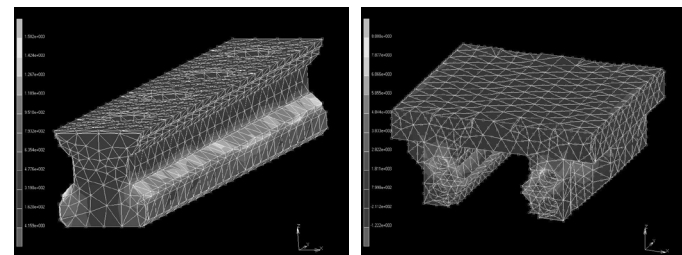

Ultra High Rigidity

Test data of rigidity

- Test samples : Ball type MSA30LE with preload F1
- Full roller type MSR30LE with preload F1
- Roller chain type SMR30LE with preload F1

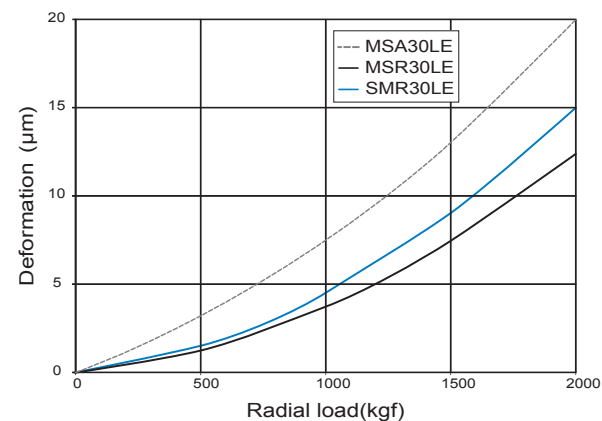
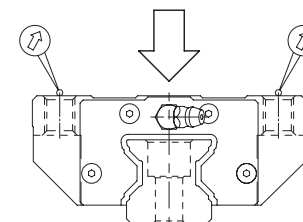

Roller Chain Design, Smooth Movement

The concise and smooth design of circulating system with strengthened synthetic resin accessories and cooperating with the roller chain, these can avoid interference between rollers and make the rollers more stability during passing in and out the load district. Besides, the roller chain can keep the roller move in a line and improve the movement most smooth substantially.

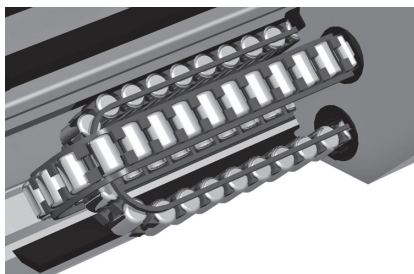

Low Noise, Good Lubricant Effect

The roller chain design avoids interference between rollers, lowers the operating noise, and can keep the lubricant between the rollers and roller chain effectively. Moreover, improve the movement smooth and service life of the whole, can meet high accuracy, high reliability and smooth and stability.

Ultra Heavy Load

SMR-LE Type

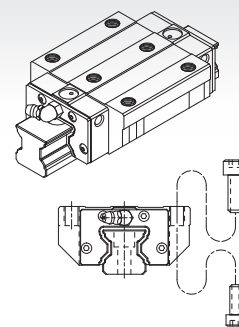

All dimensions are same as SMR-E except the length is longer, which makes it more rigid.

SMR-LS Type

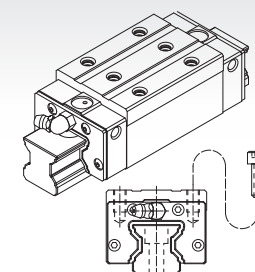

All dimensions are same as SMR-S except the length is longer, which makes it more rigid.

C. Carriage Type

Heavy Load

SMR-E Type

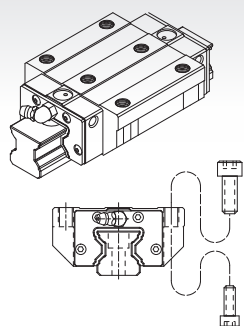

This type offers the installation either from top or bottom side of carriage.

SMR-S Type

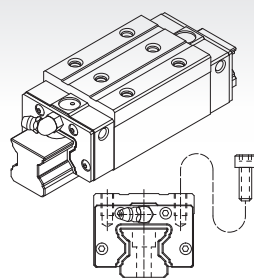

Square type with smaller width and can be installed from top side of carriage.

D. Rail Type

Counter bore (R type)

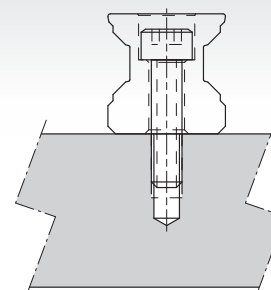

Tapped Hole (T type)

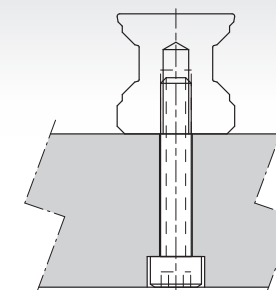

E. Description of Specification

(1) Non-interchangeable Type

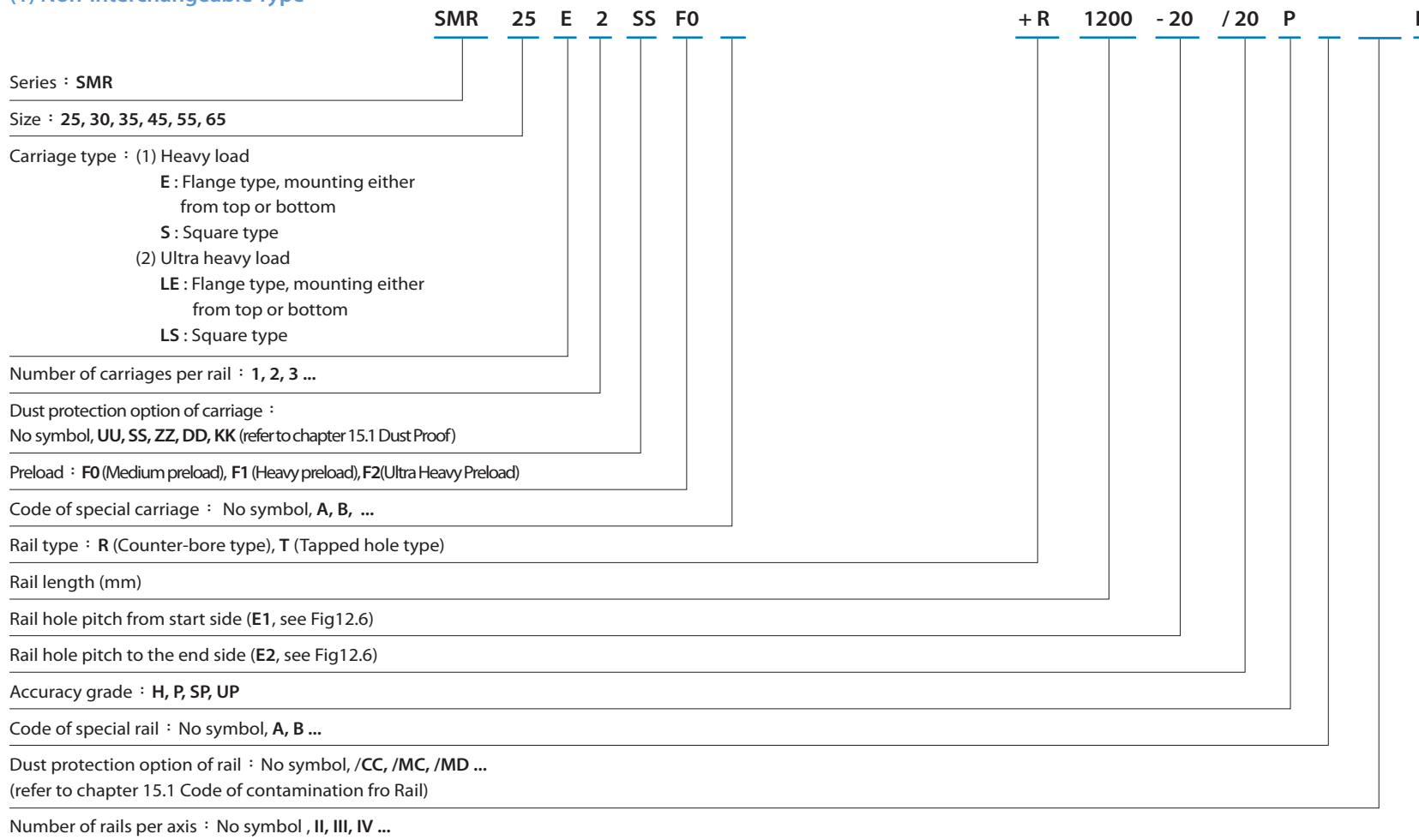

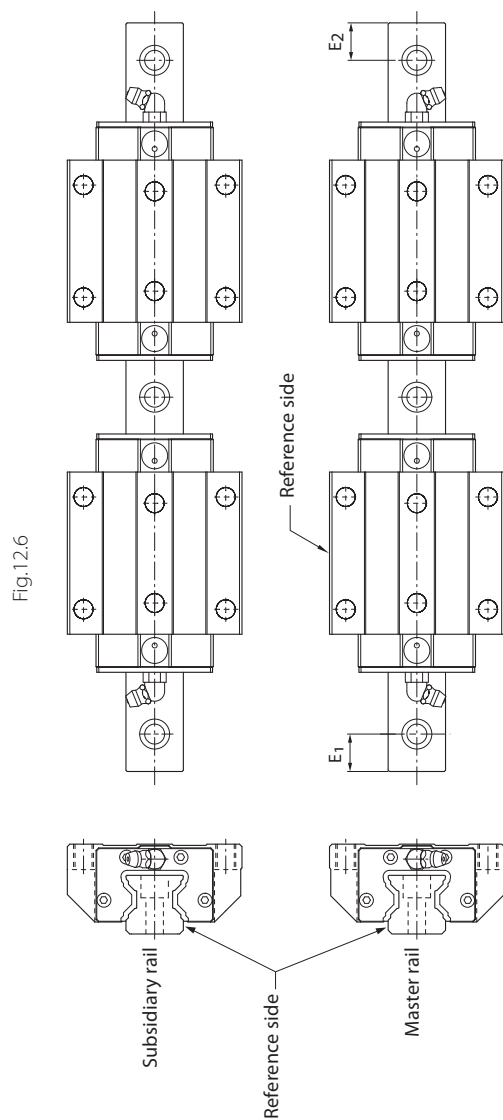

Fig.12.6

(2) Interchangeable Type

Code of Carriage

Series : **SMR**

Size : **25, 30, 35, 45, 55, 65**

Carriage type : (1) Heavy load

E : Flange type, mounting either from top or bottom

S : Square type

(2) Ultra heavy load

LE : Flange type, mounting either from top or bottom

LS : Square type

Dust protection option of carriage : No symbol, **UU, SS, ZZ, DD, KK**
(refer to chapter 15.1 Dust Proof)

Preload : **F0** (Medium preload), **F1** (Heavy preload)

Accuracy grade : **H, P**

Code of special carriage : No symbol, **A, B, ...**

SMR 25 E SS F0 H

Code of Rail

Series : **SMR**

Size : **25, 30, 35, 45, 55, 65**

Rail type : **R** (Counter-bore type), **T** (Tapped hole type)

Rail length (mm)

Rail hole pitch from start side (**E1**, see Fig.12.6)

Rail hole pitch to the end side (**E2**, see Fig.12.6)

Accuracy grade : **H, P**

Code of special rail : No symbol, **A, B ...**

Dust protection option of rail : No symbol, **/CC, /MC, /MD ...**

(refer to chapter 15.1 Code of contamination fro Rail

SMR 25 R 1200 -20 /20 H

F. Accuracy Grade

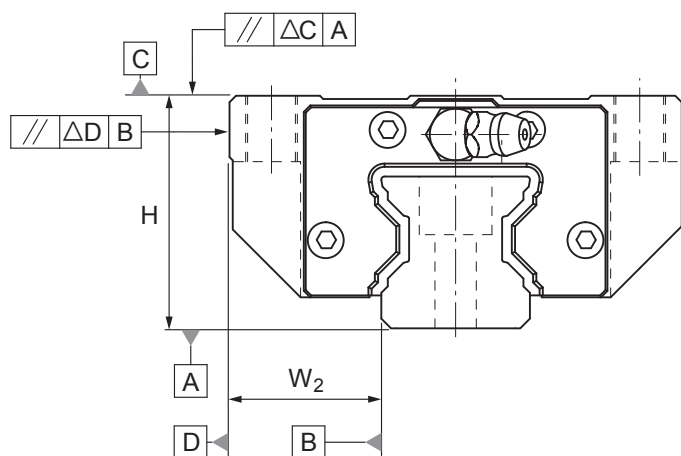

Table 1 Running Parallelism

Rail length (mm)		Running Parallelism Values(μm)			
Above	Or less	H	P	SP	UP
0	315	6	3	2	1.5
315	400	8	4	2	1.5
400	500	9	5	2	1.5
500	630	11	6	2.5	1.5
630	800	12	7	3	2
800	1000	14	8	4	2
1000	1250	16	10	5	2.5
1250	1600	18	11	6	3
1600	2000	20	13	7	3.5
2000	2500	22	15	8	4
2500	3000	24	16	9	4.5
3000	3500	25	17	11	5
3500	4000	26	18	12	6

A Non-Interchangeable Type

Model No.	Item	Accuracy Grade			
		High H	Precision P	Super Precision SP	Ultra Precision UP
25 30 35	Tolerance for height H	± 0.04	0 -0.04	0 -0.02	0 -0.01
	Height difference ΔH	0.015	0.007	0.005	0.003
	Tolerance for distance W_2	± 0.04	0 -0.04	0 -0.02	0 -0.01
	Difference in distance $W_2(\Delta W_2)$	0.015	0.007	0.005	0.003
	Running parallelism of surface C with surface A	ΔC (see the table 1)			
	Running parallelism of surface D with surface B	ΔD (see the table 1)			
45 55	Tolerance for height H	± 0.05	0 -0.05	0 -0.03	0 -0.02
	Height difference ΔH	0.015	0.007	0.005	0.003
	Tolerance for distance W_2	± 0.05	0 -0.05	0 -0.03	0 -0.02
	Difference in distance $W_2(\Delta W_2)$	0.02	0.01	0.007	0.005
	Running parallelism of surface C with surface A	ΔC (see the table 1)			
	Running parallelism of surface D with surface B	ΔD (see the table 1)			
65	Tolerance for height H	± 0.07	0 -0.07	0 -0.05	0 -0.03
	Height difference ΔH	0.02	0.01	0.007	0.005
	Tolerance for distance W_2	± 0.07	0 -0.07	0 -0.05	0 -0.03
	Difference in distance $W_2(\Delta W_2)$	0.025	0.015	0.01	0.007
	Running parallelism of surface C with surface A	ΔC (see the table 1)			
	Running parallelism of surface D with surface B	ΔD (see the table 1)			

B Interchangeable Type

Model No.	Item	Accuracy Grade	
		High H	Precision P
25 30 35	Tolerance for height H	±0.04	0 -0.04
	Height difference ΔH	0.015	0.007
	Tolerance for distance W ₂	±0.04	0 -0.04
	Difference in distance W ₂ (ΔW ₂)	0.015	0.007
	Running parallelism of surface C with surface A	ΔC (see the table 1)	
	Running parallelism of surface D with surface B	ΔD (see the table 1)	
45 55	Tolerance for height H	±0.05	0 -0.05
	Height difference ΔH	0.015	0.007
	Tolerance for distance W ₂	±0.05	0 -0.05
	Difference in distance W ₂ (ΔW ₂)	0.02	0.01
	Running parallelism of surface C with surface A	ΔC (see the table 1)	
	Running parallelism of surface D with surface B	ΔD (see the table 1)	
65	Tolerance for height H	±0.07	0 -0.07
	Height difference ΔH	0.02	0.01
	Tolerance for distance W ₂	±0.07	0 -0.07
	Difference in distance W ₂ (ΔW ₂)	0.025	0.015
	Running parallelism of surface C with surface A	ΔC (see the table 1)	
	Running parallelism of surface D with surface B	ΔD (see the table 1)	

G. Preload Grade

Series	Preload grade		
	Medium preload (F0)	Heavy preload (F1)	Ultra Heavy Preload (F2)
SMR25	0.04~0.06C	0.07~0.09C	0.12~0.14C
SMR30			
SMR35			
SMR45			
SMR55			
SMR25L	0.04~0.06C	0.07~0.09C	0.12~0.14C
SMR30L			
SMR35L			
SMR45L			
SMR55L			
SMR65L			

Note: C is basic dynamic load rating in above table. Refer to the specification of products, please.

H. The Shoulder Height and Corner Radius for Installation

SME series

Unit: mm

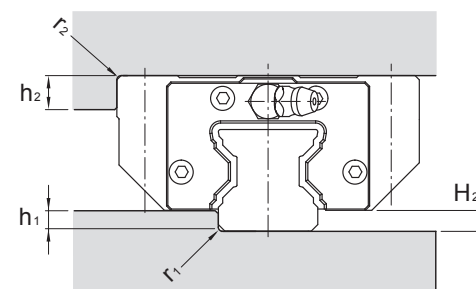

Model No.	r ₁ (max.)	r ₂ (max.)	h ₁	h ₂	H ₂
25	0.5	0.5	4	8	4.8
30	0.5	0.5	5	8	6
35	1	1	5.5	10	6.5
45	1	1	6	12	8.1
55	1	1	8	15	10
65	1	1	10	15	12

I. Dimensional Tolerance of Mounting Surface

SMR with the high rigidity, the minor dimensional error in mounting surface could be compensated and achieves smooth linear motion. The tolerances of parallelism between two axes are shown as below.

The parallel deviation between two axes (e_1)

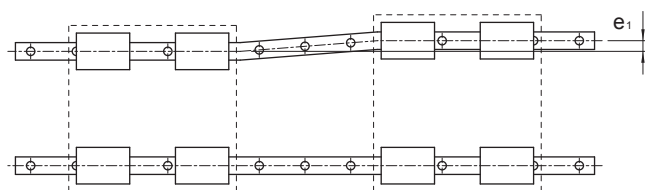

Unit: μm

Model No.	Preload Grade		
	F0	F1	F2
25	9	7	5
30	11	8	6
35	14	10	7
45	17	13	9
55	21	14	11
65	27	18	14

Level difference between two axes (e_2)

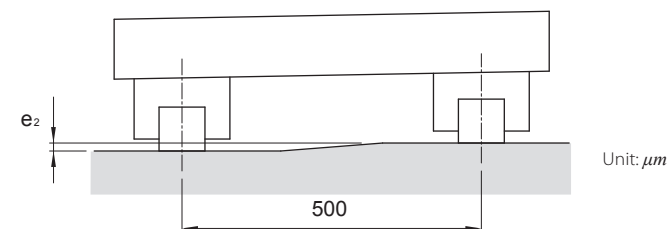

Unit: μm

Model No.	Preload Grade		
	F0	F1	F2
25	150	105	55
30			
35			
45			
55			
65			

Note: The permissible values in table are applicable when the span is 500mm wide.

J. Rail Maximum Length and Standrad

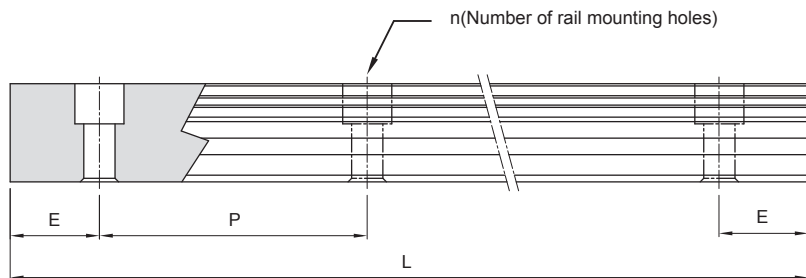

$$L = (n-1) \times P + 2 \times E$$

L : Total Length of rail (mm)

n : Nuber of mounting holes

P : Distance between any two holes (mm)

E : Distance from the center of the last hole to the edge (mm)

Unit: mm

Model No.	Standard Pitch (P)	Standard (E_{std})	Minimum ($E_{min.}$)	Max (L_0 max.)
SMR 25	30	20	7	4000
SMR 30	40	20	8	4000
SMR 35	40	20	8	4000
SMR 45	52.5	22.5	11	4000
SMR 55	60	30	13	4000
SMR 65	75	35	14	4000

K. Tapped-hole Rail Dimensions

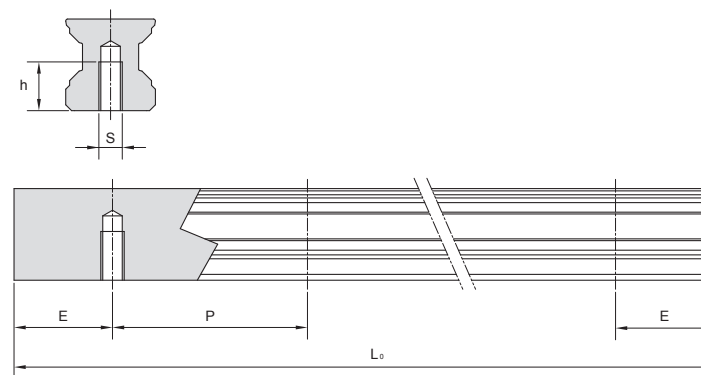

Rail Model	S	h(mm)
SMR 25 T	M6	12
SMR 30 T	M8	15
SMR 35 T	M8	17
SMR 45 T	M12	24
SMR 55 T	M14	24
SMR 65 T	M20	30

Dimensions of SMR-E / SMR-LE

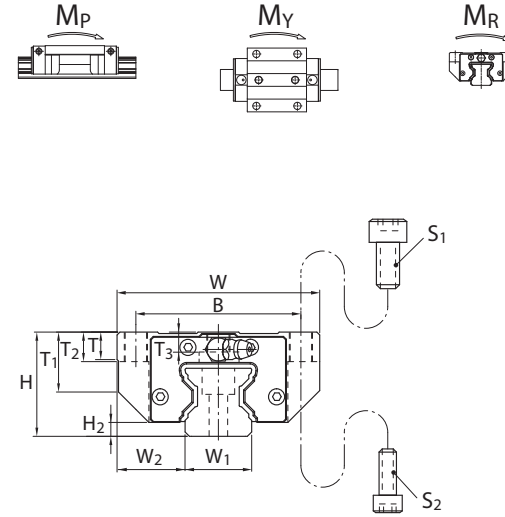
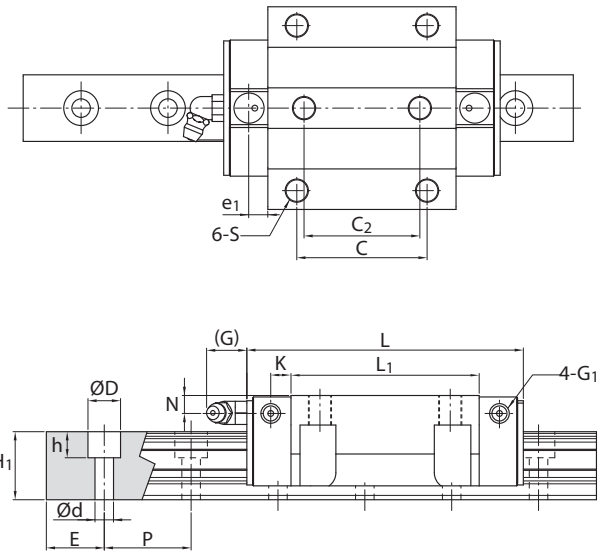

Model No.	Bolt Size	
	S_1	S_2
SMR 25	M8	M6
SMR 30	M10	M8
SMR 35	M10	M8
SMR 45	M12	M10
SMR 55	M14	M12
SMR 65	M16	M14

Unit: mm

Model No.	External dimension				Carriage dimension														Grease Nipple		
	Height H	Width W	Length L		W_2	H_2	B	C	C_2	S	L_1	T	T_1	T_2	T_3	N	G	K		e_1	G_1
SMR 25 E SMR 25 LE	36	70	97.5 115.5		23.5	4.8	57	45	40	M8	65.5 83.5	9.5	20.2	10	5.8	6	12	6.6	6.5	M6	G-M6
SMR 30 E SMR 30 LE	42	90	112.4 135.2		31	6	72	52	44	M10	75.9 98.7	10	21.6	13	6.7	7	12	8	7	M6	G-M6
SMR 35 E SMR 35 LE	48	100	125.3 153.5		33	6.5	82	62	52	M10	82.3 110.5	12	27.5	15	9.5	8	12	8	7	M6	G-M6
SMR 45 E SMR 45 LE	60	120	154.2 189.4		37.5	8	100	80	60	M12	106.5 141.7	14.5	35.5	15	12.5	10	13.5	10	10	M6	G-PT 1/8
SMR 55 E SMR 55 LE	70	140	185.4 235.4		43.5	10	116	95	70	M14	129.5 179.5	17.5	41	18	15.5	11	13.5	12	7.95	M6	G-PT 1/8
SMR 65 LE	90	170	302		53.5	12	142	110	82	M16	230	19.5	56	20	26	16.5	13.5	15	15	M6	G-PT 1/8

Note*: Single: Single carriage/ Double: Double carriages closely contacting with each other.

Unit: mm

Model No.	Rail dimension					Basic load rating		Static moment rating				Weight		
	Width W_1	Height H_1	Pitch P	E std.	$D \times h \times d$	Dynamic C kN	Static C_0 kN	M_p kN-m		M_y kN-m		M_r kN-m	Carriage kg	Rail kg/m
								Single*	Double*	Single*	Double*			
SMR 25 E SMR 25 LE	23	23.5	30	20	11×9×7	27.4 33.1	57.4 73.3	0.63 1.01	3.63 5.49	0.63 1.01	3.63 5.49	0.66 0.84	0.75 0.95	3.5
SMR 30 E SMR 30 LE	28	27.5	40	20	14×12×9	39.5 49.4	82.7 110.3	1.01 1.78	5.90 9.60	1.01 1.78	5.90 9.60	1.15 1.53	1.4 1.72	5
SMR 35 E SMR 35 LE	34	30.5	40	20	14×12×9	55.6 69.6	117.0 156.0	1.63 2.86	9.59 15.57	1.63 2.86	9.59 15.57	1.98 2.63	1.95 2.45	7
SMR 45 E SMR 45 LE	45	37	52.5	22.5	20×17×14	89.3 110.6	184.1 242.2	3.27 5.6	18.48 29.56	3.27 5.6	18.48 29.56	4.18 5.5	3.9 4.5	11.2
SMR 55 E SMR 55 LE	53	43	60	30	23×20×16	127.8 163.2	256.5 351.0	5.51 10.16	30.89 53.02	5.51 10.16	30.89 53.02	6.96 9.52	6 7.9	15.6
SMR 65 LE	63	52	75	35	26×22×18	263.5	583.7	21.49	111.99	21.49	111.99	18.73	17.6	22.4

Dimensions of SMR-S / SMR-LS

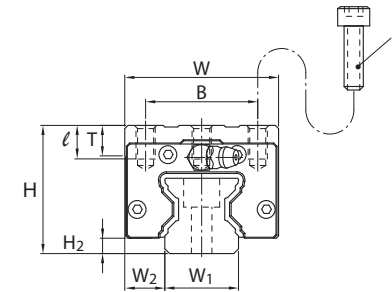
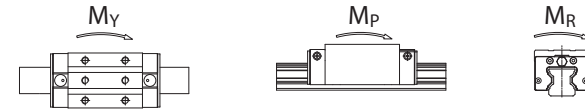
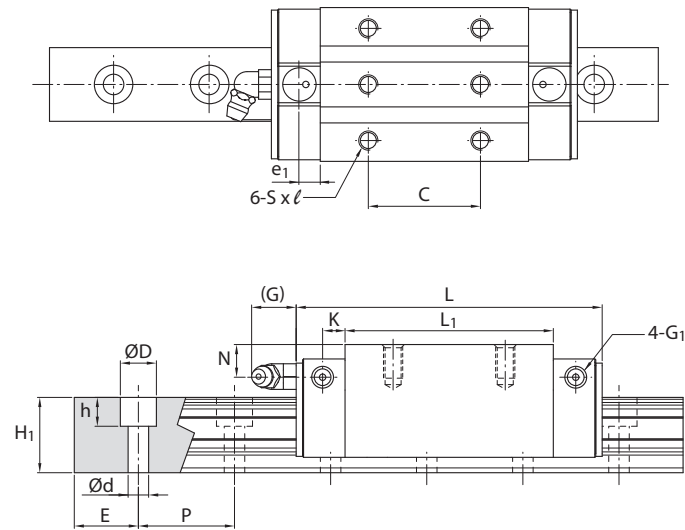

Unit: mm

Model No.	External dimension					Carriage dimension											Grease Nipple
	Height H	Width W	Length L	W_2	H_2	B	C	S	ℓ	L_1	T	N	G	K	e_1	G_1	
SMR 25 S SMR 25 LS	40	48	97.5 115.5	12.5	4.8	35	35 50	M6	10.5	65.5 83.5	9.5	10	12	6.6	6.5	M6	G-M6
SMR 30 S SMR 30 LS	45	60	112.4 135.2	16	6	40	40 60	M8	12	75.9 98.7	10	10	12	8	7	M6	G-M6
SMR 35 S SMR 35 LS	55	70	125.3 153.5	18	6.5	50	50 72	M8	14	82.3 110.5	12	15	12	8	7	M6	G-M6
SMR 45 S SMR 45 LS	70	86	154.2 189.4	20.5	8	60	60 80	M10	19	106.5 141.7	17	20	13.5	10	10	M6	G-PT 1/8
SMR 55 S SMR 55 LS	80	100	185.4 235.4	23.5	10	75	75 95	M12	19	129.5 179.5	18	21	13.5	12	7.95	M6	G-PT 1/8
SMR 65 LS	90	126	302	31.5	12	76	120	M16	20	230	19.5	16.5	13.5	15	15	M6	G-PT 1/8

* : Single: Single carriage/ Double: Double carriages closely contacting with each other.

Unit: mm

Model No.	Rail dimension					Basic load rating		Static moment rating				Weight		
	Width W_1	Height H_1	Pitch P	E std.	$D \times h \times d$	Dynamic C	Static C_0	M_p		M_v		M_R	Carriage kg	Rail kg/m
								Single*	Double*	Single*	Double*			
SMR 25 S SMR 25 LS	23	23.5	30	20	11×9×7	27.4 33.1	57.4 73.3	0.63 1.01	3.63 5.49	0.63 1.01	3.63 5.49	0.66 0.84	0.65 0.85	3.5
SMR 30 S SMR 30 LS	28	27.5	40	20	14×12×9	39.5 49.4	82.7 110.3	1.01 1.78	5.90 9.60	1.01 1.78	5.90 9.60	1.15 1.53	1 1.22	5
SMR 35 S SMR 35 LS	34	30.5	40	20	14×12×9	55.6 69.6	117.0 156.0	1.63 2.86	9.59 15.57	1.63 2.86	9.59 15.57	1.98 2.63	1.65 2.15	7
SMR 45 S SMR 45 LS	45	37	52.5	22.5	20×17×14	89.3 110.6	184.1 242.2	3.27 5.6	18.48 29.56	3.27 5.6	18.48 29.56	4.18 5.5	3.2 4.1	11.2
SMR 55 S SMR 55 LS	53	43	60	30	23×20×16	127.8 163.2	256.5 351.0	5.51 10.16	30.89 53.02	5.51 10.16	30.89 53.02	6.96 9.52	5.1 7	15.6
SMR 65 LS	63	52	75	35	26×22×18	263.5	583.7	21.43	111.99	21.43	111.99	18.73	13.3	22.4

12.7 wide rail type MSG series

A. Construction

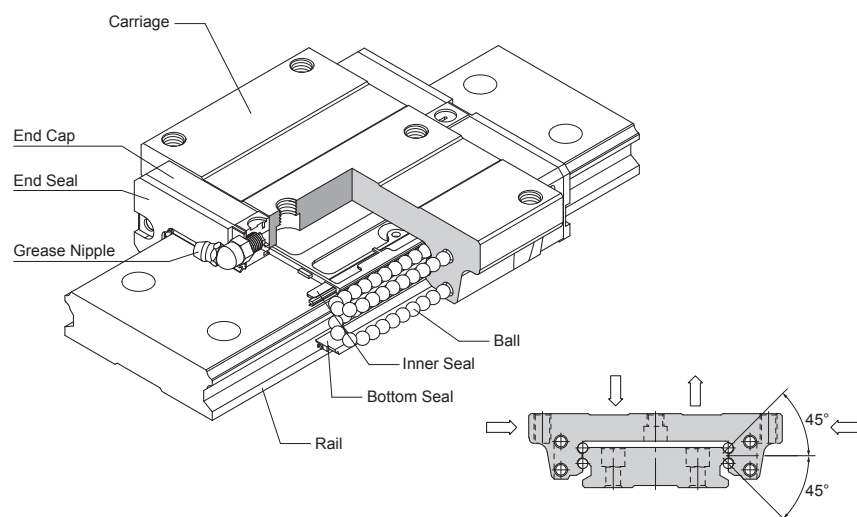

B. Characteristics

The trains of balls are designed to a contact angle of 45° which enables it to bear an equal load in radial, reversed radial and lateral directions. Therefore, it can be applied in any installation direction. Furthermore, MSG series can achieve a well balanced preload for increasing rigidity in four directions while keeping a low frictional resistance. This is especially suit to high precision and high rigidity required motion. By design, the ability to use a single rail and to have the low profile with a low center of gravity is ideal where space is limited and high moments are required.

The patent design of lubrication route makes the lubricant evenly distribute in each circulation loop. Therefore, the optimum lubrication can be achieved in any installation direction, and this promotes the performance in running accuracy, service life, and reliability.

High Rigidity, Four-way Equal Load

The four trains of balls are allocated to a circular contact angle at 45° , thus each train of balls can take up an equal rated load in all four directions. Moreover, a sufficient preload can be achieved to increase rigidity, and this makes it suitable for any kind of installation.

Smooth Movement with Low Noise

The simplified design of circulating system with strengthened synthetic resin accessories makes the movement smooth and quiet.

Self Alignment Capability

The self adjustment is performed spontaneously as the design of face-to-face (DF) circular arc groove. Therefore, the installation error could be compensated even under a preload, and which results in precise and smooth linear motion.

Interchangeability

For interchangeable type of linear guideway, the dimensional tolerances are strictly maintained within a reasonable range, and this has made the random matching of the same size of rails and carriages possible. Therefore, the similar preload and accuracy can be obtained even under the random matching condition. As a result of this advantage, the linear guideway can be stocked as standard parts, the installation and maintenance become more convenient. Moreover, this is also beneficial for shortening the delivery time.

C. Carriage Type

wide rail type

MSG-E Type

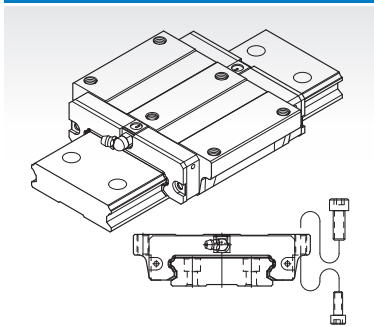

This type offers the installation either from top or bottom side of carriage.

MSG-S Type

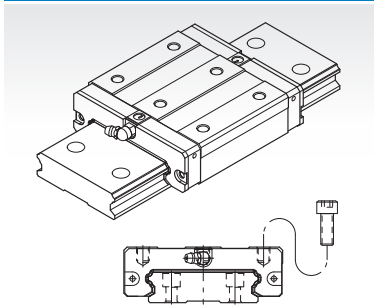

Square type with smaller width and can be installed from top side of carriage.

D. Rail Type

Counter bore (R type)

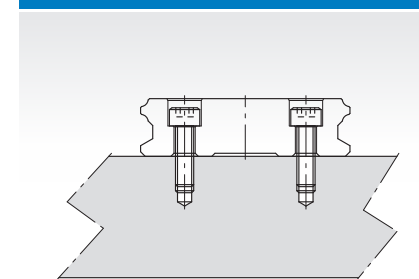

E. Description of Specification

(1) Non-Interchangeable Type

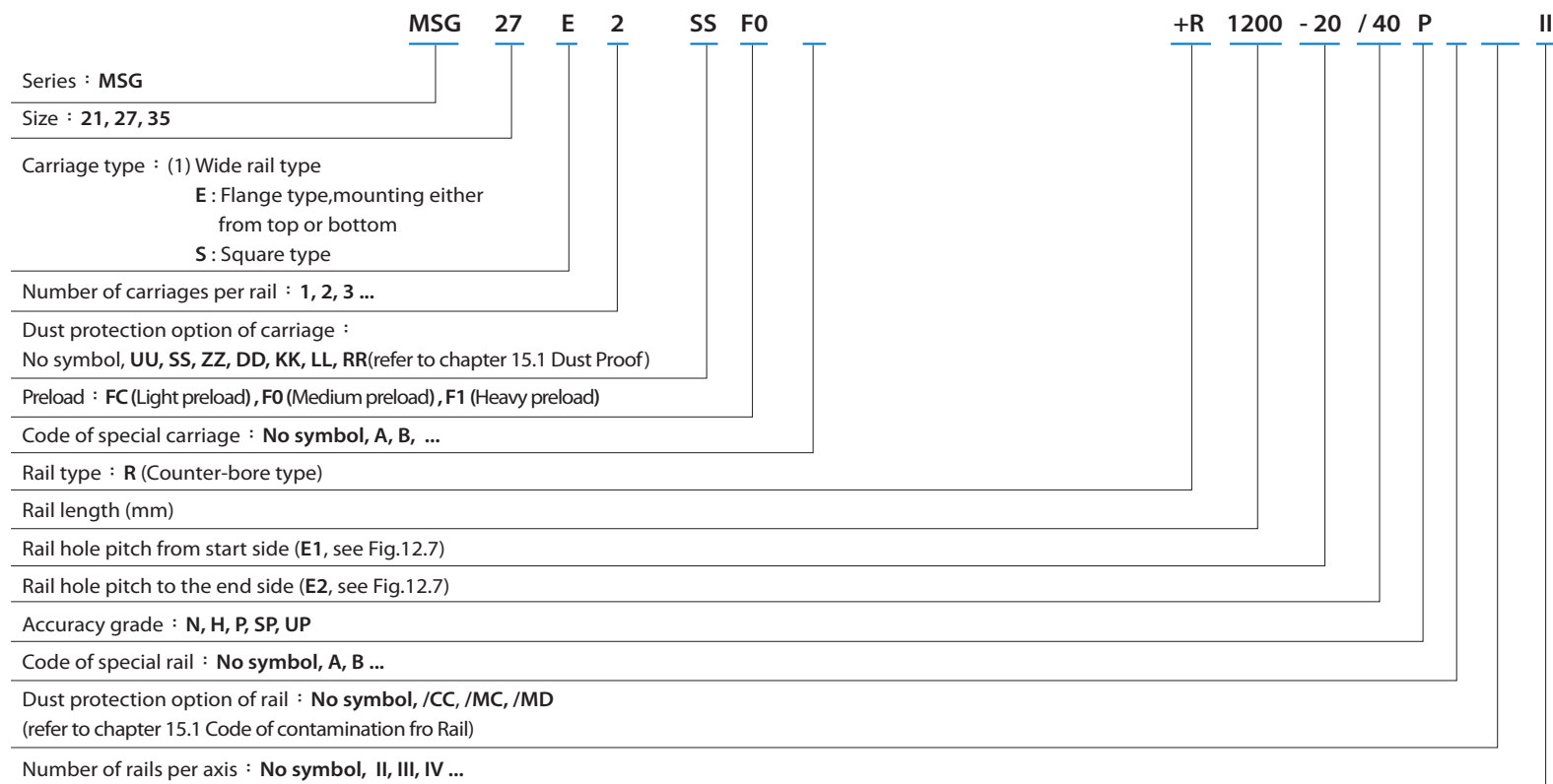

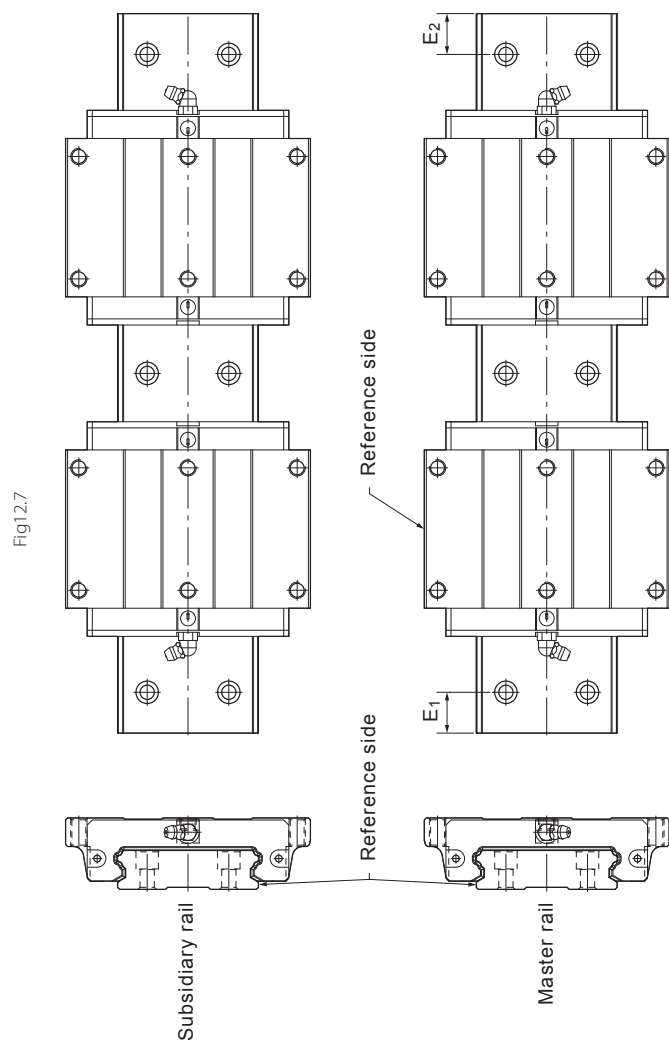

Fig12.7

(2) Interchangeable Type

Code of Carriage

Series : MSG

Size : 21 27 35

Carriage type : (1) Wide rail type
 E : Flange type, mounting either from top or bottom
 S : Square type

Dust protection option of carriage : **No symbol, UU, SS, ZZ, DD, KK, LL, RR**
 (refer to chapter 15.1 Dust Proof)

Preload : **FC** (Light preload), **F0** (Medium preload)

Accuracy grade : **N, H, P**

Code of special carriage : **No symbol, A, B, ...**

Code of Rail

Series : MSG

Size : 21 27 35

Rail type : R (Counter-bore type)

Rail length (mm) : 1200

Rail hole pitch from start side (**E1**, see Fig.12.7) : -20

Rail hole pitch to the end side (**E2**, see Fig.12.7) : /40

Accuracy grade : **N, H, P**

Code of special rail : **No symbol, A, B ...**

Dust protection option of rail : **No symbol, /CC, /MC**
 (refer to chapter 15.1 Code of contamination fro Rail)

F. Accuracy Grade

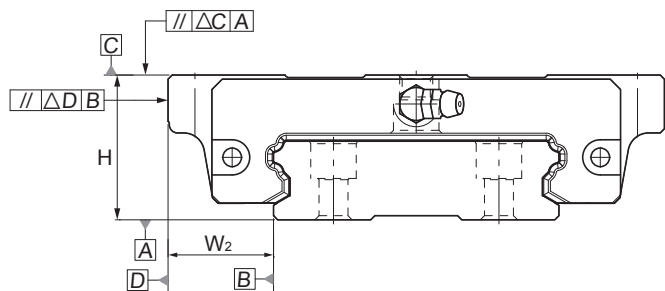

Table 1 Running Parallelism

Rail length (mm)		Running Parallelism Values(μm)				
Above	Or less	N	H	P	SP	UP
0	315	9	6	3	2	1.5
315	400	11	8	4	2	1.5
400	500	13	9	5	2	1.5
500	630	16	11	6	2.5	1.5
630	800	18	12	7	3	2
800	1000	20	14	8	4	2
1000	1250	22	16	10	5	2.5
1250	1600	25	18	11	6	3
1600	2000	28	20	13	7	3.5
2000	2500	30	22	15	8	4
2500	3000	32	24	16	9	4.5
3000	3500	33	25	17	11	5
3500	4000	34	26	18	12	6

A Non-Interchangeable Type

Model No.	Item	Accuracy Grade				
		Normal N	High H	Precision P	Super Precision SP	Ultra Precision UP
21	Tolerance for height H	± 0.1	± 0.03	0 -0.03	0 -0.015	0 -0.008
	Height difference ΔH	0.02	0.01	0.006	0.004	0.003
	Tolerance for distance W_2	± 0.1	± 0.03	0 -0.03	0 -0.015	0 -0.008
	Difference in distance $W_2(\Delta W_2)$	0.02	0.01	0.006	0.004	0.003
	Running parallelism of surface C with surface A	ΔC (see the table 1)				
	Running parallelism of surface D with surface B	ΔD (see the table 1)				
27 35	Tolerance for height H	± 0.1	± 0.04	0 -0.04	0 -0.02	0 -0.01
	Height difference ΔH	0.02	0.015	0.007	0.005	0.003
	Tolerance for distance W_2	± 0.1	± 0.04	0 -0.04	0 -0.02	0 -0.01
	Difference in distance $W_2(\Delta W_2)$	0.03	0.015	0.007	0.005	0.003
	Running parallelism of surface C with surface A	ΔC (see the table 1)				
	Running parallelism of surface D with surface B	ΔD (see the table 1)				

B Interchangeable Type

Model No.	Item	Accuracy Grade		
		Normal N	High H	Precision P
21	Tolerance for height H	±0.1	±0.03	0 -0.03
	Height difference ΔH	0.02	0.01	0.006
	Tolerance for distance W ₂	±0.1	±0.03	0 -0.03
	Difference in distance W ₂ (ΔW ₂)	0.02	0.01	0.006
	Running parallelism of surface C with surface A	ΔC (see the table 1)		
	Running parallelism of surface D with surface B	ΔD (see the table 1)		
27 35	Tolerance for height H	±0.1	±0.04	0 -0.04
	Height difference ΔH	0.02	0.015	0.007
	Tolerance for distance W ₂	±0.1	±0.04	0 -0.04
	Difference in distance W ₂ (ΔW ₂)	0.03	0.015	0.007
	Running parallelism of surface C with surface A	ΔC (see the table 1)		
	Running parallelism of surface D with surface B	ΔD (see the table 1)		

G. Preload Grade

Series	Preload grade		
	Light preload (FC)	Medium preload (F0)	Heavy preload (F1)
MSG21	0~0.02C	0.03~0.05C	0.05~0.08C
MSG27			
MSG35			

Note: C is basic dynamic load rating in above table. Refer to the specification of products, please.

H. The Shoulder Height and Corner Radius for Installation

MSG series

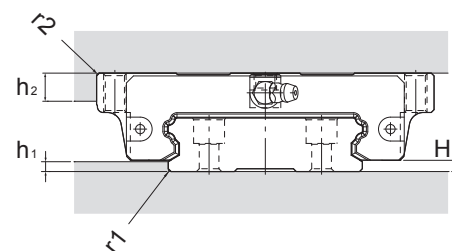

Unit: mm

Model No.	r ₁ (max.)	r ₂ (max.)	h ₁	h ₂	H ₂
21	0.4	0.4	2.5	5	3
27	0.4	0.4	2.5	7	3
35	0.8	0.8	3.5	10	4

I. Dimensional Tolerance of Mounting Surface

MSG Series

With the self alignment capability, the minor dimensional error in mounting surface could be compensated and achieves smooth linear motion. The tolerances of parallelism between two axes are shown as below.

The parallel deviation between two axes (e₁)

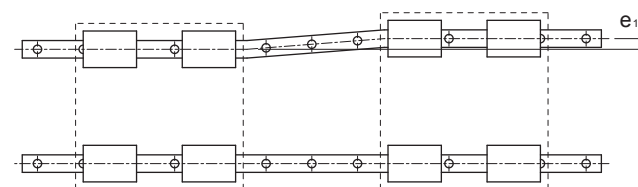

Unit: μm

Model No.	Preload Grade		
	FC	F0	F1
21	-	25	18
27	-	25	20
35	30	22	20

Level difference between two axes (e_2)

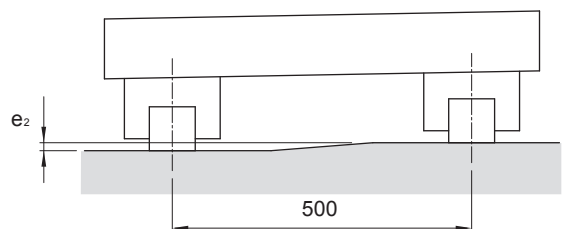

J. Rail Maximum Length and Standrad

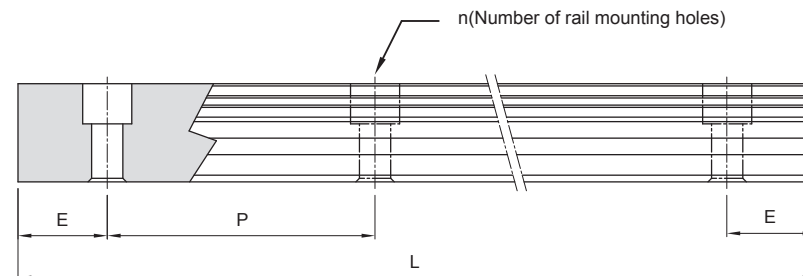

$$L = (n-1) \times P + 2 \times E$$

L : Total Length of rail (mm)

n : Nuber of mounting holes

P : Distance between any two holes (mm)

E : Distance from the center of the last hole to the edge (mm)

Unit: μm

Model No.	Preload Grade		
	FC	F0	F1
21	130	85	-
27	130	85	-
35	130	85	70

Note: The permissible values in table are applicable when the span is 500mm wide.

Unit: mm

Model No.	Standard Pitch (P)	Standard (E_{std})	Minimum (E_{min})	Max (L_0 max.)
MSG 21	60	20	5	4000
MSG 27	60	20	6	4000
MSG 35	60	20	7	4000

Dimensions of MSG-E

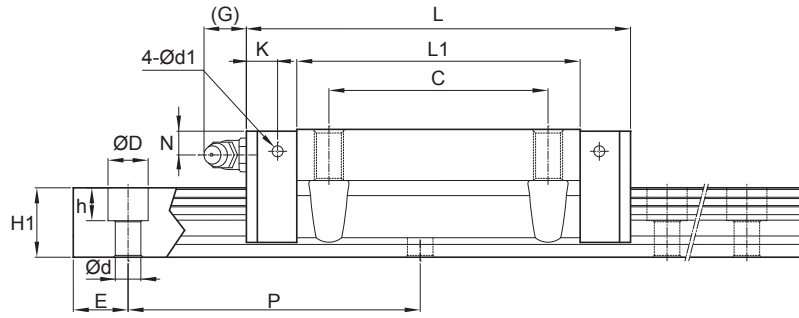

Unit: mm

Model No.	External dimension			Carriage dimension													Grease Nipple
	Height H	Width W	Length L	W ₂	H ₂	B	C	F	S × l	L ₁	T	N	G	K	d ₁		
MSG21 E	21	68	59	15.5	3	60	29	22	M5	40	8	5	12	2.5	2.5	G-M6	
MSG27 E	27	80	73	19	3	70	40	24	M6	51.8	8	6	12	3	3.3	G-M6	
MSG35 E	35	120	105.2	25.5	4	107	60	40	M8	77.6	11.2	6	12	8.55	3.3	G-M6	

Note: The basic dynamic load rating C of ball type is based on the 50 km for nominal life. The conversion between C for 50 km and C₁₀₀ for 100 km is C=1.26 × C₁₀₀.

Note*: Single: Single carriage/ Double: Double carriages closely contacting with each other.

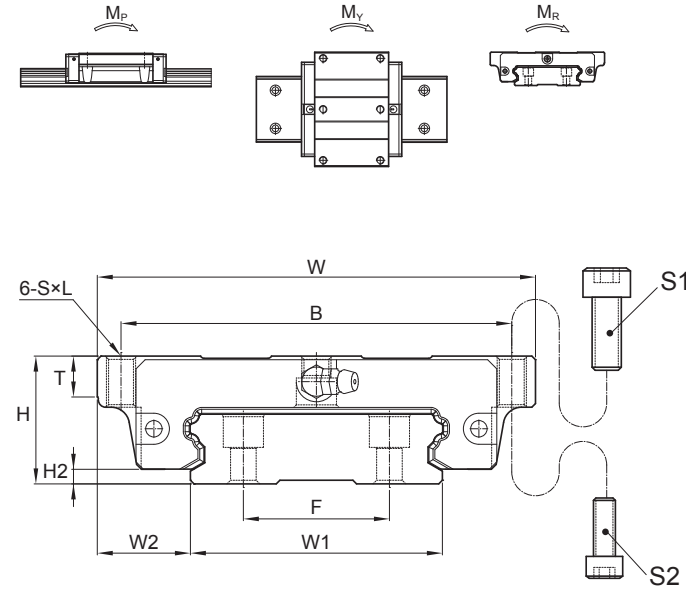

Model No.	Bolt Size	
	S ₁	S ₂
MSG 21	M5	M4
MSG 27	M6	M5
MSG 35	M8	M6

Unit: mm

Model No.	Rail dimension					Basic load rating		Static moment rating				Weight		
	Width W ₁	Height H ₁	Pitch P	E std.	D × h × d	Dynamic C kN	Static C ₀ kN	M _x kN-m		M _y kN-m		M _z kN-m	Carriage kg	Rail kg/m
								Single*	Double*	Single*	Double*			
MSG21 E	37	11	50	15	7.5×5.3×4.5	7	12.1	0.08	0.46	0.08	0.46	0.22	0.25	2.86
MSG27 E	42	15	60	20	7.5×5.3×4.5	12.4	20.2	0.15	0.87	0.15	0.87	0.42	0.31	4.49
MSG35 E	69	19	80	20	11×9×7	30.7	48.6	0.65	3.6	0.65	3.6	1.67	0.99	9.4

Dimensions of MSG-S

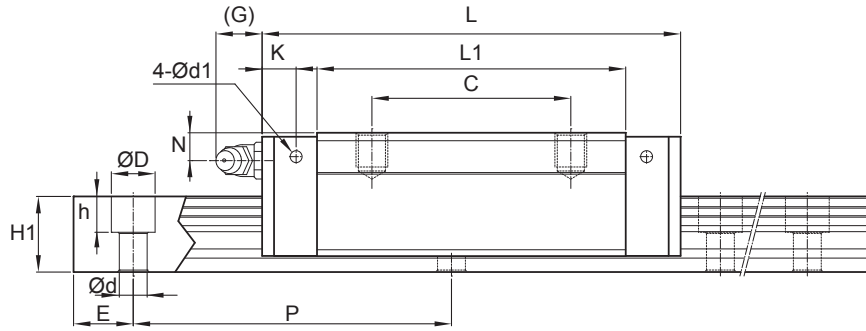

Unit: mm

Model No.	External dimension			Carriage dimension													Grease Nipple
	Height H	Width W	Length L	W ₂	H ₂	B	C	F	S × l	L ₁	T	N	G	K	d ₁		
MSG21 S	21	54	59	8.5	3	31	19	22	M5×6	40	8	5	12	2.5	2.5	G-M6	
MSG27 S	27	62	73	10	3	46	32	24	M6×6	51.8	10	6	12	3	3.3	G-M6	
MSG35 S	35	100	105.2	15.5	4	76	50	40	M8×8	77.6	10	6	12	8.55	3.3	G-M6	

Note: The basic dynamic load rating C of ball type is based on the 50 km for nominal life. The conversion between C for 50 km and C₁₀₀ for 100 km is C=1.26 × C₁₀₀.

Note*: Single: Single carriage/ Double: Double carriages closely contacting with each other.

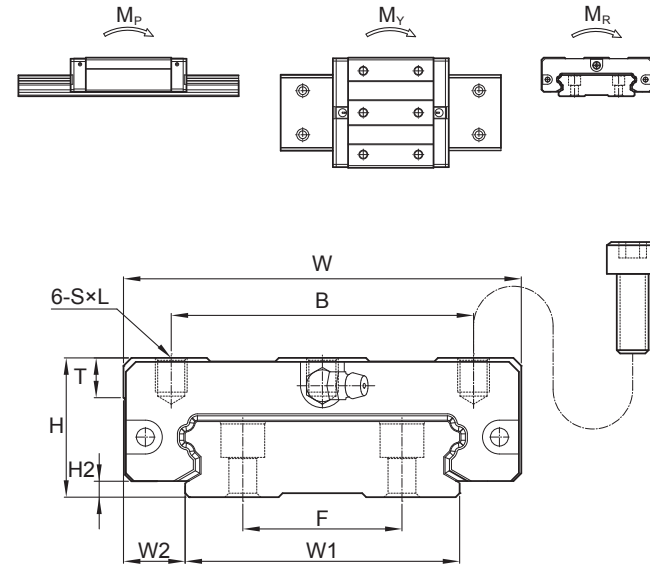

Unit: mm

Model No.	Rail dimension					Basic load rating		Static moment rating				Weight		
	Width W ₁	Height H ₁	Pitch P	E std.	D × h × d	Dynamic C kN	Static C ₀ kN	M _x kN-m		M _y kN-m		M _r kN-m	Carriage kg	Rail kg/m
								Single*	Double*	Single*	Double*			
MSG21 S	37	11	50	15	7.5×5.3×4.5	7	12.1	0.08	0.46	0.08	0.46	0.22	0.25	2.86
MSG27 S	42	15	60	20	7.5×5.3×4.5	12.4	20.2	0.15	0.87	0.15	0.87	0.42	0.31	4.49
MSG35 S	69	19	80	20	11×9×7	30.7	48.6	0.65	3.6	0.65	3.6	1.67	0.99	9.4

13 Point of Design

13.1 Installation Direction of Linear Guideway

The installation direction of linear guideway depends on machine structure and load direction. When oil lubrication is applied, the lubricant routing will be varied with different applications. Therefore, please specify the direction of installation when ordering.

Horizontal (Code : H)

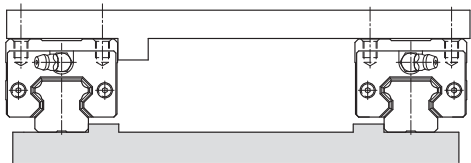

Inverted (Code : R)

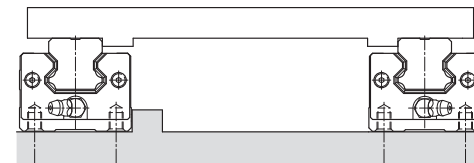

Vertical (Code : V)

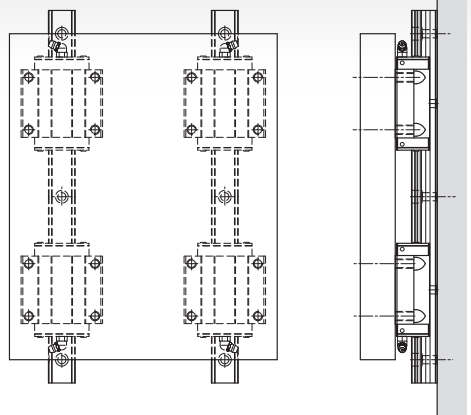

Opposed (Code : F)

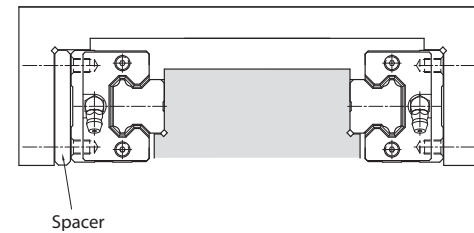

Wall mounting (Code : K)

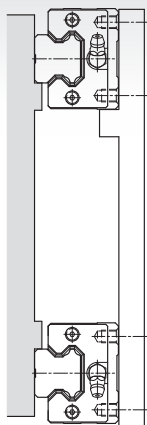

Tilted (Code : T)

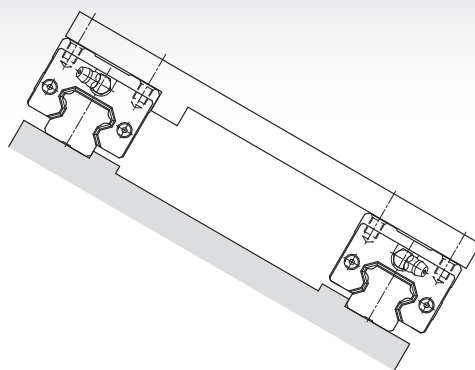

13.2 Fixing Methods of Linear Guideway

The rail and carriage could be displaced when machine receives vibration or impact. Under such situation, the running accuracy and service life will be degraded, so the following fixing methods are recommended for avoiding such situation happens.

Shoulder plate (Recommended)

For this method, the rail and carriage should stick out slightly from the bed and table. To avoid interference from corner of carriage and rail, the shoulder plate should have a recess.

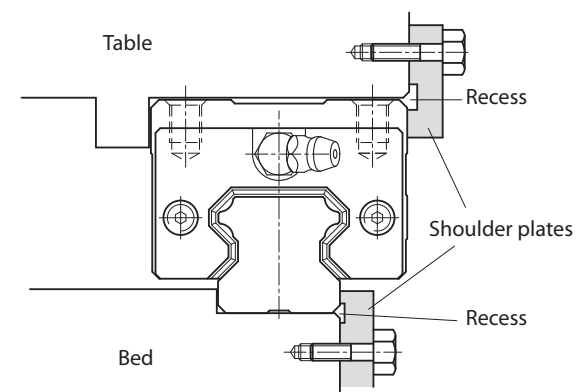

Taper gib

A slight tightening of the taper gib could generate a large pressing force to the linear guideway, and this may cause the rail to deform. Thus, this method should be carried with caution.

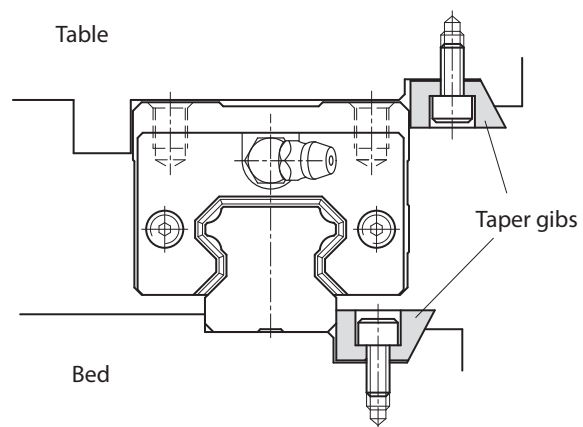

Needle roller

The needle roller is pressed by the taper section of the head of screw, so the position of screw should be paid attention.

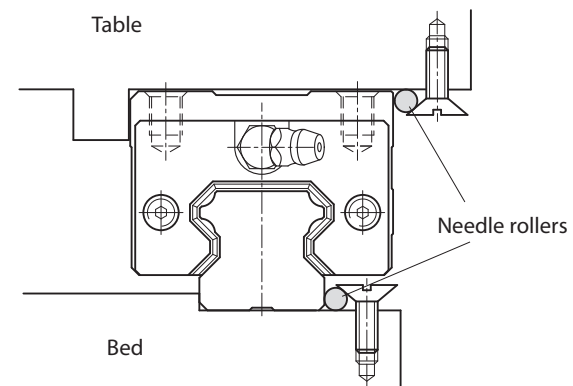

Push screw

Due to the limitation of installation space, the size of bolt should be thin.

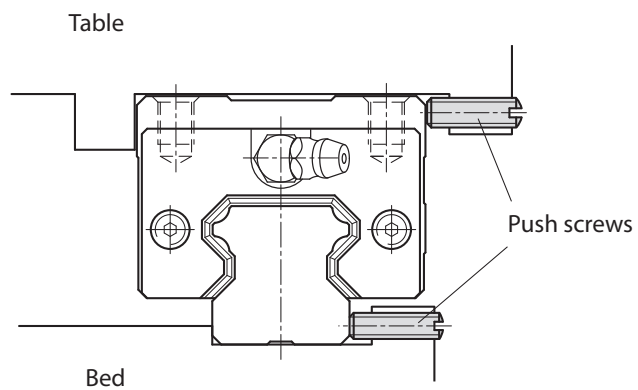

13.3 Marking on Master Linear Guideway and Combined Case

Recognizing of Reference Side

The reference side of rail is assigned by the arrow sign which is marked together with the model code and lot number on top surface of rail while that of carriage is the side which is opposed to the side marked with lot number and model code marked, as shown below.

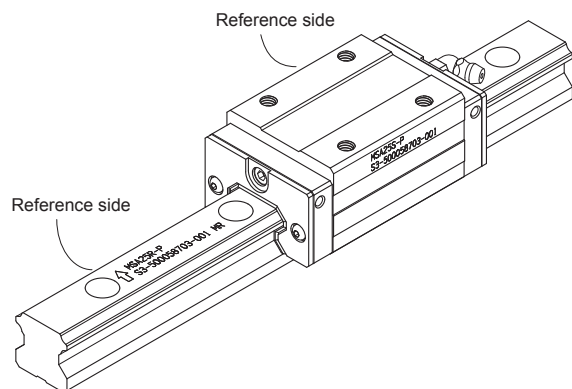

Marking on Rail

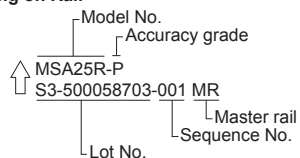

Marking on Carriage

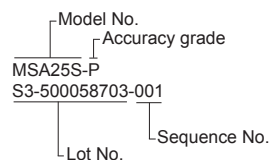

Recognizing of reference side

Recognizing of Master Rail

Linear rails to be applied on the same plane are all marked with the same serial number, and "MR" is marked at the end of serial number for indicating the master rail, shown as the figure below. The reference side of carriage is the surface where is ground to a specified accuracy. For normal grade (N), it has no mark "MR" on rail which means any one of rails with same serial number could be the master rail.

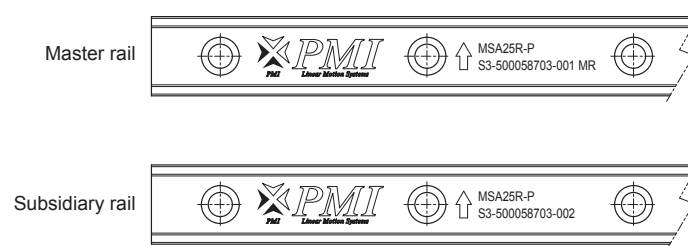

Recognizing of master rail

Combined Use of Rail and Carriage

For combined use, the rail and carriage must have the same serial number. When reinstalling the carriage back to the rail, make sure they have the same serial number and the reference side of carriage should be in accordance with that of rail.

14 Installation of Linear Guideway

For Butt-joint Rail

When applied length of rail longer than specified max. length, the rails can be connected to one another. For this situation, the joint marks indicate the matching position. Accuracy may deviate at joints when carriages pass the joint simultaneously. Therefore, the joints should be interlaced for avoiding such accuracy problem.

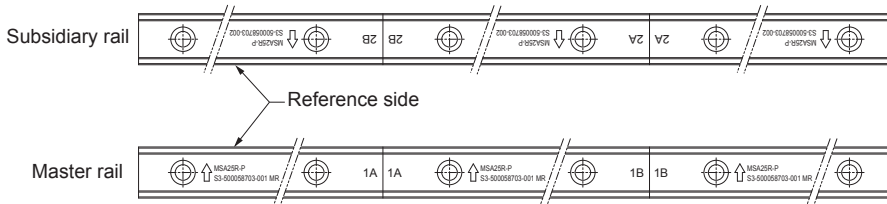

Identification of butt-joint rail

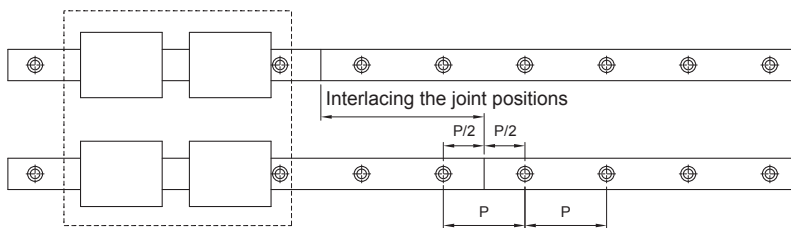

Staggering the joint position

14.1 Installation of Linear Guideway When Machine Subjected to Vibration and Impact

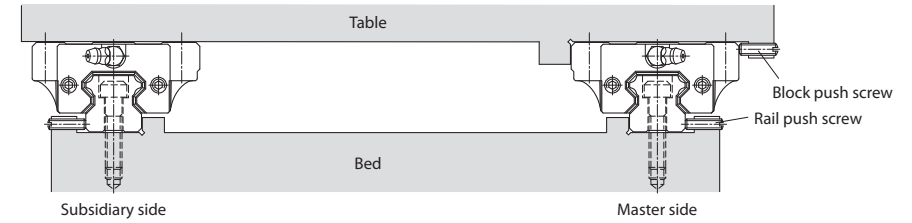

(1) Installation of rail

step.1

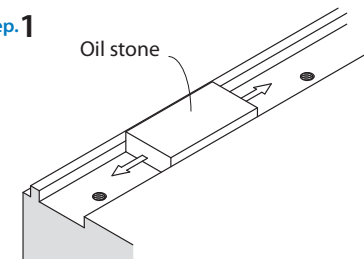

Prior to installation, the burrs, dirt, and rust preventive oil should be removed thoroughly.

step.2

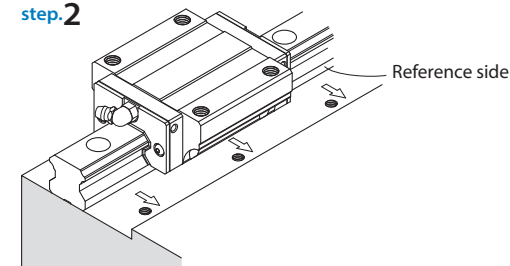

Gently place the linear guideway on the bed, and pushing it against the reference side of bed.

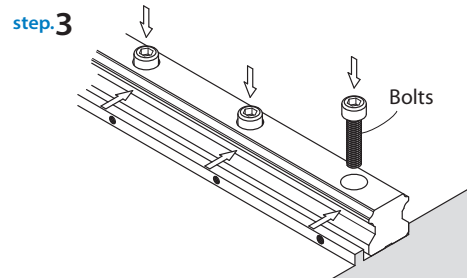

Check for correct bolt play and temporarily tighten all bolts.

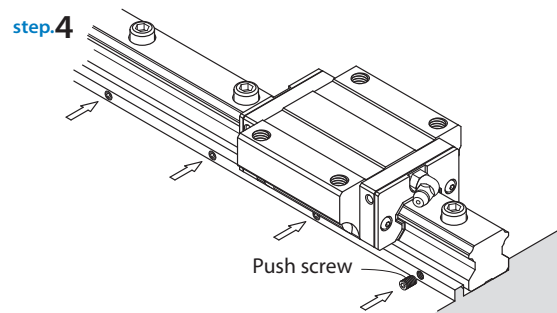

Tighten the push screw in sequence to ensure the rail close matching the reference side of bed.

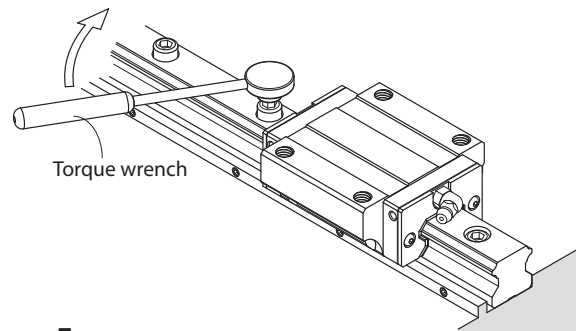

step.5

Tighten all bolts to the specified torque. The tightening sequence should start from the right side to the left side. By doing this, the original accuracy could be achieved.

step.6

Follow the same procedure for the installation of remaining rails.

(2) Installation of carriage

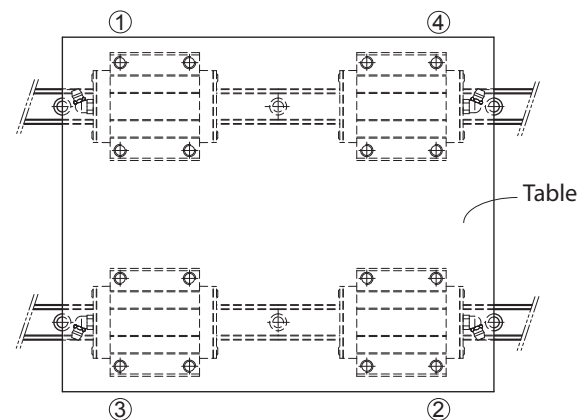

step.1

Gently place table onto carriages and temporarily tighten the bolts.

step.2

Tighten the push screw to hold the master rail carriage against the table reference side, and position the table.

step.3

Fully tighten all bolts on both master and subsidiary sides. The tightening process should be followed by the order of ① to ④.

14.2 Installation of Linear Guideway without Push Screws

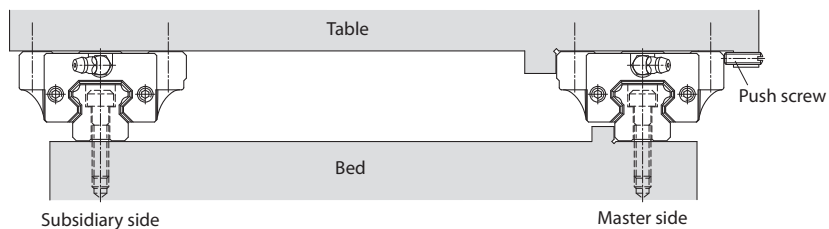

(1) Installation of master rail

Using a vise

First tighten the mounting bolts temporarily, then use a C vise to press the master rail to reference side. Tighten the mounting bolts in sequence to specified torque.

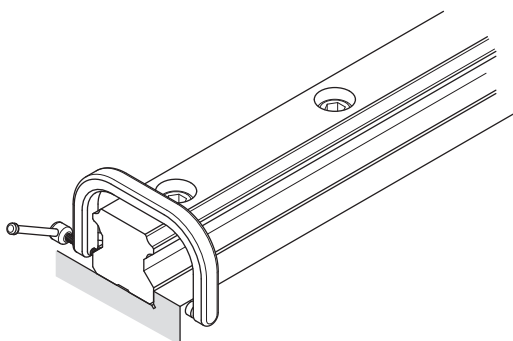

(2) Installation of subsidiary rail

Using a straight edge

Place a straight edge between the two rails and position it parallel to the reference side rail which is temporarily tightened by bolts. Check the parallelism with dial gauge, and align the rail if necessary. Then tighten the bolts in sequence.

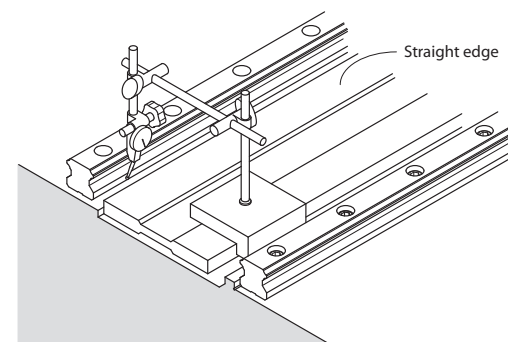

Using a table

Tighten two master side carriages and one subsidiary side carriage onto the table. Then temporarily tighten another subsidiary carriage and rail to the table and bed. Position a dial gauge on the table and have the probe of dial gauge contact the side of the subsidiary carriage. Move the table from the rail end and check the parallelism between the carriage and the subsidiary rail. Then tighten the bolts in sequence.

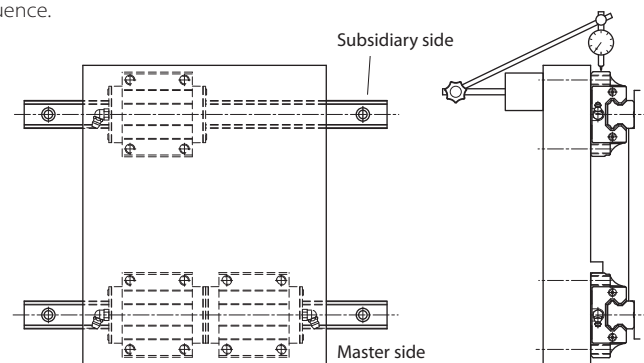

Compare to master rail side

Tighten two master side carriages and one subsidiary side carriage onto the table. Then temporarily tighten another subsidiary carriage and rail to the table and bed. Move the table from one rail, check and align the parallelism of subsidiary rail based on moving resistance. Tighten the bolts in sequence.

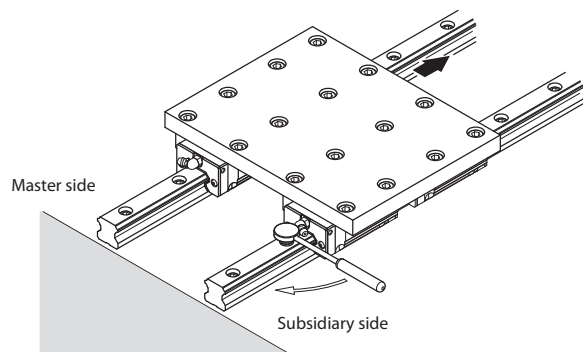

14.3 The Installation of Carriage of Linear Guideway without the Reference Side for Master Rail

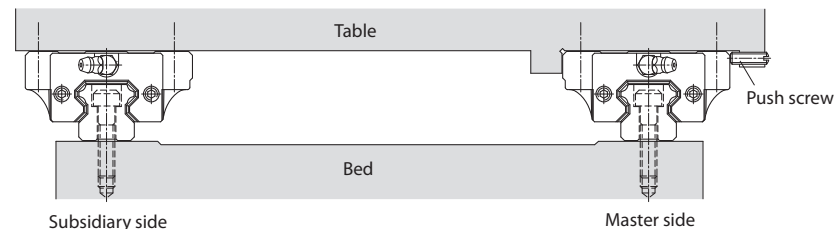

(1) Mounting the master rail

Using a temporary reference side

Two carriages are tightened together onto the measuring plate, and set up a temporary reference surface near the rail mounting surface on the bed. Check and align the parallelism of rails and then tighten bolts sequentially.

Using a jig

Using the special jig to align the parallelism between the reference side of master rail and that of subsidiary rail from one rail end to another. Tighten the mounting bolts in sequence.

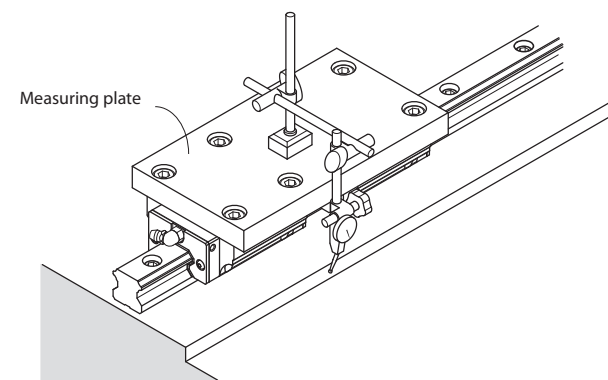
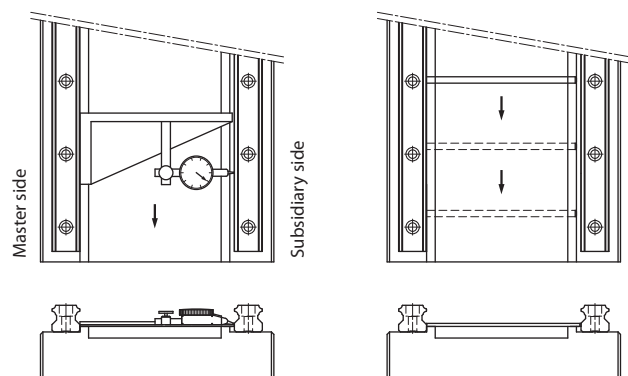

Using a straight edge

At first temporarily tighten rail onto the bed, then use a dial gauge to align the straightness of rail. Tighten the bolts in sequence.

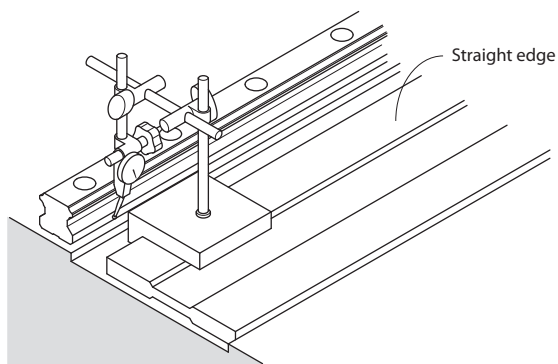

(2) The installation of subsidiary carriage and rail is same as the prior examples

14.4 Accuracy Measurement after Installation

The running accuracy can be obtained by tightening the two carriages onto the measuring plate. A dial gauge or autocollimator is used for measuring the accuracy. If a dial gauge is used, the straight edge should be placed as close to carriage as possible for accurate measurement.

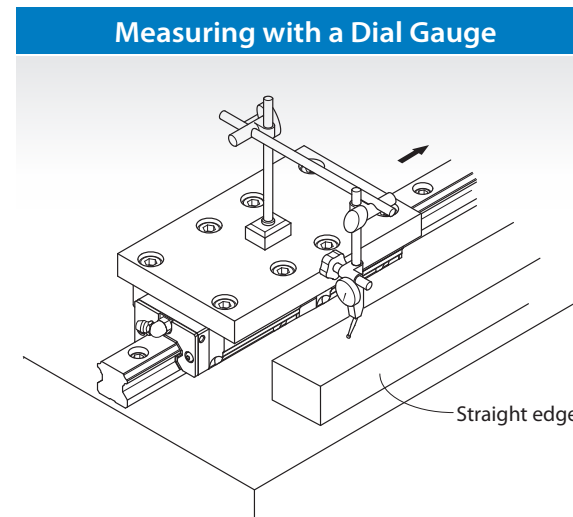
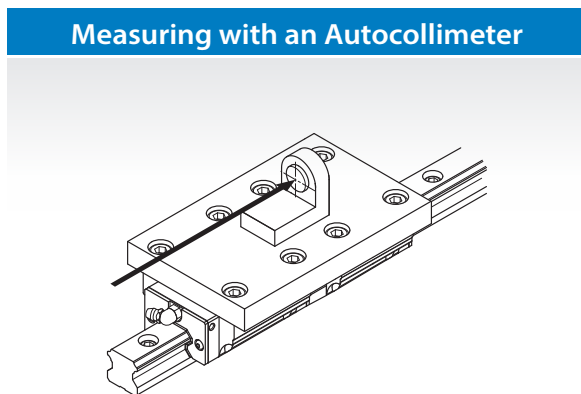

14.5 The Recommended Tightening Torque for Rails

The improper tightening torque could affect the mounting accuracy, so tightening the bolts by torque wrench to specified torque is highly recommended. Different types of mounting surface should have different torque value for applications.

Unit: N·m

Bolt Model	Torque Value		
	Iron	Cast iron	Aluminum
M2	0.6	0.4	0.3
M3	2	1.3	1
M4	4	2.7	2
M5	8.8	5.9	4.4
M6	13.7	9.2	6.8
M8	30	20	15
M10	68	45	33
M12	120	78	58
M14	157	105	78
M16	196	131	98
M20	382	255	191

* 1 N·m = 0.738 lbf·ft

15.1 Dust Proof

A. Code of contamination protection

Code of contamination protection for Carriage

MSA \ MSB Series :

Code	Contamination Protection
no symbol	Scraper(both ends)
UU	Bidirectional end seal(both ends)
SS	Bidirectional end seal+Bottom seal
ZZ	SS+Scraper
DD	Double bidirectional end seal+Bottom seal
KK	DD+Scraper
LL	Low frictional end seal
RR	LL+Bottom seal
HD	high dust end seal +high dust inner and bottom seal (supply MSA15~35 , MSB15~20)

SME \ SMR \ MSR Series :

Code	Contamination Protection
no symbol	Scraper(both ends)
UU	Bidirectional end seal(both ends)
SS	Bidirectional end seal+Bottom seal+Inner seal
ZZ	SS+Scraper
DD	Double bidirectional end seal+Bottom seal+Inner seal
KK	DD+Scraper

MSC \ MSD Series :

Code	Contamination Protection
LL	Low frictional end seal
RR	LL+Bottom seal

Code of contamination protection for Rail

MSA \ MSB \ SME \ MSR \ SMR Series :

Code	Contamination Protection
/CC	Cover strip
/MC	Copper bolt cap
/MD	Stainless bolt cap

Note: There are two metallic bolt caps of copper and stainless that could be supplied by customer's choice.

Seal materials choice

Beside the standard seal NBR that FKM (Fluorocarbon Rubber) seal or HNBR (Hydrogenated Nitrile Butadiene Rubber) seal could be supplied as requirement by customer's choice.

B. Contamination protection

Each series of linear guideway offers various kinds of dust protection accessory to keep the foreign matters from entering into the carriage.

End seal

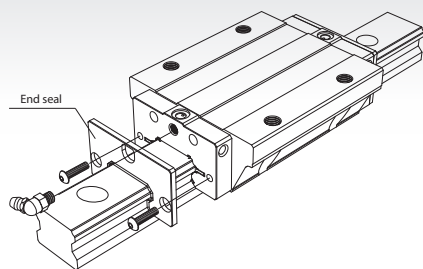

Two types sealing are available:

1. Bidirectional seal for high dust protection required.
2. Monodirectional seal for low frictional resistance required.

Bottom seal

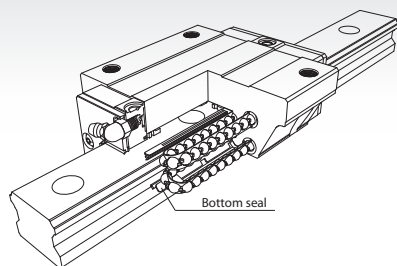

Prevent the inclusion of foreign matters from the bolt hole.

Inner Seal

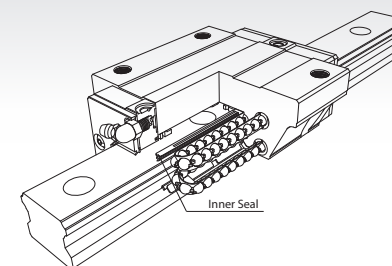

Preventing the inclusion of foreign matters from bottom of carriage.

Metal scraper

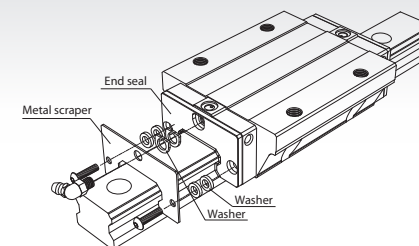

Removing spatters, iron chips, and large foreign matters as well as protecting the end seals.

Enhanced Dust-proof

According to the environmental and operational conditions, *PMI* provide enhanced contamination protection could be supplied as requirement by customer's choice, the excellent of enhanced contamination protection to prevent dust enter the carriage.

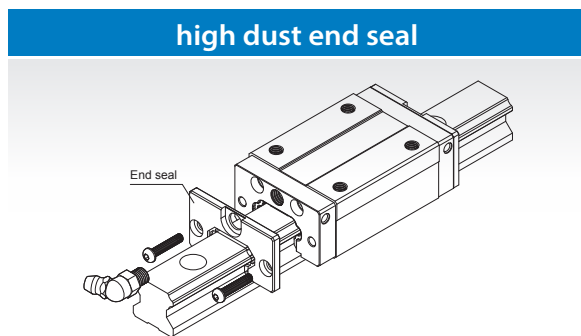

offer special design bidirectional end seal

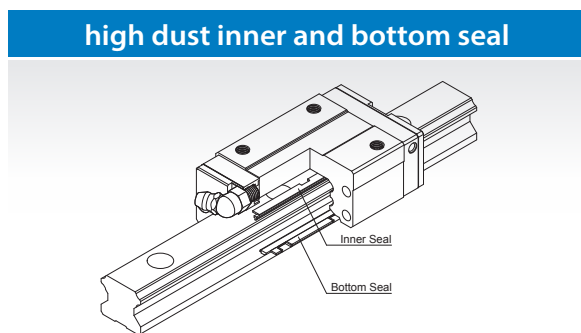

Prevent the foreign matters enter the carriage from the bolt hole.

Types of seal to the carriage overall length, see the table shown as below

MSA Series

Unit: mm

Model No.	No symbol	UU	SS	LL	RR	ZZ	DD	KK	HD
15	1	-	-	-	-	6	5	11	1
20	1.4	-	-	-	-	7	5.6	12.6	0.4
25	1.4	-	-	-	-	7	5.6	12.6	0.4
30	1.4	-	-	-	-	7	5.6	12.6	0.4
35	0.6	-	-	-	-	7.8	7.2	15	-
45	0.6	-	-	-	-	7.8	7.2	15	-
55	-	-	-	-	-	7.8	7.8	15.6	-
65	-	-	-	-	-	7.8	7.8	15.6	-

MSB Series

Unit: mm

Model No.	No symbol	UU	SS	LL	RR	ZZ	DD	KK	HD
15	-	-	-	-	-	5	5	10	1
20	1	-	-	-	-	7	6	13	-
25	1	-	-	-	-	7	6	13	-
30	1	-	-	-	-	7	6	13	-
35	0.6	-	-	-	-	7.8	7.2	15	-

SME Series

Unit: mm

Model No.	no symbol	UU	SS	ZZ	DD	KK
15	0.4	-	-	6	5.6	11.6
20	1	-	-	7	6	13
25	1	-	-	7	6	13
30	1.4	-	-	7	5.6	12.6
35	1	-	-	7.8	6.8	14.6
45	0.6	-	-	7.8	7.2	15

MSR \ SMR Series

Unit: mm

Model No.	no symbol	UU	SS	ZZ	DD	KK
25	2	-	-	6	6	12
30	2	-	-	7	6	13
35	2	-	-	7	6	13
45	1.6	-	-	7	6.4	13.4
55	0.8	-	-	7.8	7.2	15
65	0.8	-	-	7.8	7.8	15.6

MSG Series

Unit: mm

Model No.	no symbol	UU	SS	ZZ	DD	KK
21	1.4	-	-	7.4	6	13.4
27	1.4	-	-	7.4	6	13.4
35	1.4	-	-	7.8	6	13.8

Resistance value of seal

MSA series

The maximum resistance value of MSA series with seals type UU when it is applied with grease is shown below.

Unit: N

Model No.	Resistance	
	UU	HD
15	2	18
20	3.5	19
25	4	30
30	6	23
35	10	25
45	12	-
55	18	-
65	30	-

MSB series

The maximum resistance value of MSB series with seals type UU when it is applied with grease is shown below.

Unit: N

Model No.	Resistance	
	UU	HD
15	2	18
20	3.5	19
25	4	-
30	6	-
35	10	-

MSC \ MSD series

The maximum resistance value of MSC series with seals type LL when it is applied with grease is shown below.

MSC

Unit: N

Model No.	Resistance
7	0.08
9	0.1
12	0.4
15	0.8

MSD

Unit: N

Model No.	Resistance
7	0.4
9	0.8
12	1.1
15	1.3

MSR \ SMR series

The maximum resistance value of MSR and SMR series with seals type UU when it is applied with grease is shown below.

Unit: N

Model No.	Resistance
25	4.5
30	8
35	12
45	18
55	20
65	35

SME series

The maximum resistance value of SME series with seals type UU when it is applied with grease is shown below.

Unit: N

Model No.	Resistance
15	2
20	3.5
25	4
30	6
35	10
45	12

C. Cover Strip

A special designed of cover strip is used to cover the bolt hole to prevent the foreign matters from entering the carriage. Please specify when ordering.

Note:When mounting the cover strip the rail needs to be machined.Indicate that the cover strip is required when ordering the guideway. The cover strip could not increase the height of rail.

MSA \ MSB \ SME \ MSR \ SMR series

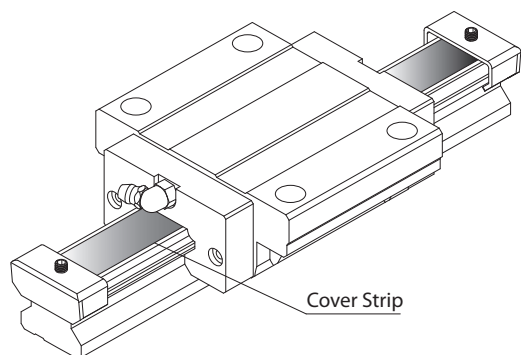

D. Caps for rail mounting hole

A special designed of cap is used to cover the bolt hole to prevent the foreign matters from entering the carriage. According to difference of application, *PMI* provide two kind of caps for selection, made by plastic and metal. The metallic cap is for opyion,please specify when ordering. The plastic cap is mounted by using a plastic hammer with a flat pad placed on the top,until the top of cap is flush to the top surface of rail.The dimension of caps for different sizes of rail is shown.

Installation of plastic and metal cap

According to the environmental and operational conditions, choose plastic or metal, plastic and metal model cap size, please refer to Table I Table II.

The steps of installing bolt cap with rail by below indicated figures

step.1

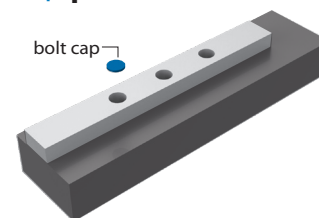

Put the cap into the bolt hole of rail.

step.2

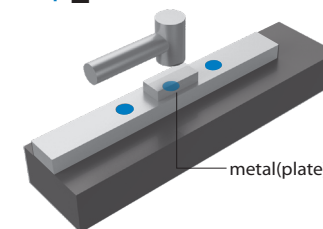

Put the plate on the cap,then pound it into the bolt of rail with rubber hammer vertically.

step.3

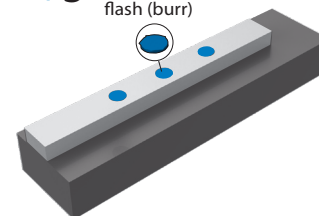

Clear the "shaving " away from the side of bolt hole.

step.4

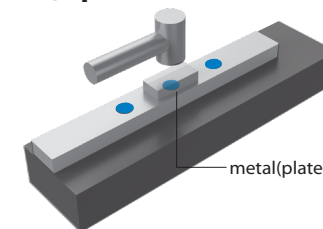

Continue pounding the cap until the cap is on the same plane with the top surface of rail.

step.5

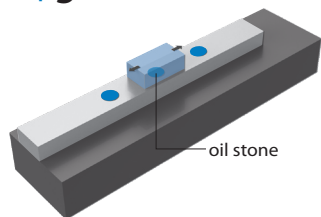

Use oil stone to polish the surface of caps and mop them with clean bunny cloth. And finally check the installation is good for smoothing by your finger.

Install attention:

Owing to the side of hole is very sharp during installation. Therefore, pay special attention for safety in case of finger and hands be slashed.

Table I

Code of Plastic Cap	Bolt Size	Rail Model					
M3C	M3		MSB15R				
M4C	M4	MSA15R	MSB15U		SME15R		MSG21R MSG27R
M5C	M5	MSA20R	MSB20R		SME20R		
M6C	M6	MSA25R	MSB25R MSB30R	MSR25R	SME25R	SMR25R	MSG35R
M8C	M8	MSA30R MSA35R	MSB35R	MSR30R MSR35R	SME30R SME35R	SMR30R SMR35R	
M12C	M12	MSA45R		MSR45R	SME45R	SMR45R	
M14C	M14	MSA55R		MSR55R		SMR55R	
M16C	M16	MSA65R		MSR65R		SMR65R	

Table II

Code of Metallic Cap	Bolt Size	Rail Model					
M4MC	M4	MSA15R	MSB15U		SME15R		MSG21R MSG27R
M5MC	M5	MSA20R	MSB20R		SME20R		
M6MC	M6	MSA25R	MSB25R MSB30R	MSR25R	SME25R	SMR25R	MSG35R
M8MC	M8	MSA30R MSA35R	MSB35R	MSR30R MSR35R	SME30R SME35R	SMR30R SMR35R	
M12MC	M12	MSA45R		MSR45R	SME45R	SMR45R	
M14MC	M14	MSA55R		MSR55R		SMR55R	
M16MC	M16	MSA65R		MSR65R		SMR65R	

15.2 Lubrication

A well lubrication is important for maintaining the function of linear guideway. If the lubrication is not sufficient, the frictional resistance at rolling area will increase and the service life will be shortened as a result of wear of rolling parts.

Two primary lubricants are both grease and oil used for linear motion system, and the lubrication methods are categorized into manual and forced oiling. The selection of lubricant and its method should be based on the consideration of operating speed and environment requirement.

Grease lubrication

The grease feeding interval will be varied with different operating conditions and environments. Under normal operating condition, the grease should be replenished every 100km of travel. The standard grease is lithium-based grease No.2. Moving the carriage back and forth with minimum stroke length of length of 3 carriages after the carriages been greased. To assure the grease is evenly distributed inside of carriage, the mentioned process should be repeated twice at least.

Grease amount to be bed

Model No.	Initial Feeding Amount(cm ³)	Amount for Replenishing(cm ³)
MSA 15	1.1	0.4
MSA 20	2.1	0.7
MSA 25	3.5	1.2
MSA 30	5.8	1.9
MSA 35	8.2	2.7
MSA 45	16.1	5.4
MSA 55	27.1	9.0
MSA 65	51.6	17.2
MSB 15T	0.4	0.1
MSB 20T	0.7	0.2
MSB 25T	1.5	0.5
MSB 30T	2.2	0.7
MSB 35	8.2	2.7
MSR 25	4.5	1.5
MSR 30	7.0	2.3
MSR 35	9.6	3.2
MSR 45	17.1	5.7
MSR 55	26.0	8.7
-	-	-
MSC 7	0.06	0.02
MSC 9	0.16	0.05
MSC 12	0.25	0.08
MSC 15	0.49	0.16
MSD 7	0.19	0.06
MSD 9	0.42	0.14
MSD 12	0.73	0.24
MSD 15	1.51	0.50
SME 15	1.6	0.5
SME 20	2.6	0.9
SME 25	4.1	1.4
SME 30	6.0	2.0
SME 35	9.7	3.2
SME 45	13.2	4.4
SMR 25	5.9	2.0
SMR 30	8.8	2.9
SMR 35	12.6	4.2
SMR 45	21.0	7.0
SMR 55	32.1	10.7
-	-	-

Model No.	Initial Feeding Amount(cm ³)	Amount for Replenishing(cm ³)
-	-	-
MSA 20L	3.1	1.0
MSA 25L	5.1	1.7
MSA 30L	8.2	2.7
MSA 35L	11.8	3.9
MSA 45L	23.0	7.7
MSA 55L	38.8	12.9
MSA 65L	77.8	25.9
MSB 15	1.0	0.3
MSB 20	1.5	0.5
MSB 25	2.8	0.9
MSB 30	4.5	1.5
MSB 35L	11.8	3.9
MSR 25L	5.5	1.8
MSR 30L	8.7	2.9
MSR 35L	12.3	4.1
MSR 45L	22.0	7.3
MSR 55L	34.3	11.4
MSR 65L	64.8	21.6
MSC 7L	0.11	0.04
MSC 9L	0.24	0.08
MSC 12L	0.42	0.14
MSC 15L	0.80	0.27
MSD 7L	0.28	0.09
MSD 9L	0.60	0.20
MSD 12L	1.07	0.36
MSD 15L	2.18	0.73
-	-	-
SME 20L	3.6	1.2
SME 25L	5.2	1.7
SME 30L	8.1	2.7
SME 35L	13.0	4.3
SME 45L	18.5	6.2
SMR 25L	7.2	2.4
SMR 30L	11.0	3.7
SMR 35L	16.0	5.3
SMR 45L	26.5	8.8
SMR 55L	42.6	14.2
SMR 65L	76.1	25.4
MSG 21	1.2	0.4
MSG 27	2.1	0.7
MSG 35	5.6	1.9

Oil lubrication

The recommended viscosity of oil is 30~150 cst, and the recommended feeding rate per hour is shown as table below. The installation other than horizontal may caused the oil unable to reach raceway area, so please specify the installed direction your linear guideway applied. Reference is shown in Section 13.1 Installation Direction of Linear Guideway.

Oil lubrication feeding rate

Model No.	Initial Feeding Amount(cm ³)	Feeding Rate (cm ³ /hr)
15	0.6	0.2
20	0.6	0.2
25	0.9	0.3
30	0.9	0.3
35	0.9	0.3
45	1.2	0.4
55	1.5	0.5
65	1.8	0.6
MSG 21	0.6	0.2
MSG 27	0.9	0.3
MSG 35	0.9	0.3

Note:

When the operating stroke length less than the sum of length of two carriages, the lubrication fitting should be applied on both ends of carriage for adequacy. Moreover, if the stroke length less than a half of the length of a carriage, the carriage should be moved back and forth up to the length of two carriages while lubricating.

A. SL Lubricator

1. Construction and Characteristics

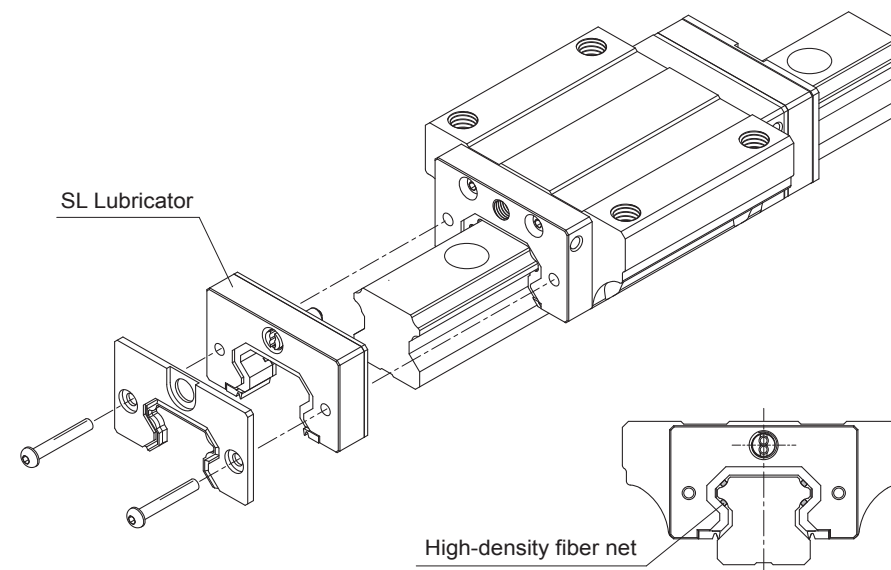

Characteristics

PMI SL lubricator unit is designed with an oil reservoir which equipped with a high-density fiber net. Through the fiber net the lubricant can be steadily fed onto the surface of raceway to satisfy the required lubricating function.

1. Lengthening the interval between maintenance works

Contrary to the oil losing problem caused from ordinary lubrication, the SL lubricator effectively and evenly distribute needed amount of oil on to ball raceway during the movement. Therefore, the interval between maintenance works can be greatly extended.

2. To avert the pollution

Through the use of SL lubricator, only the needed amount of oil will be fed for the purpose of lubrication, thereby the oil is almost nothing to lose in application. As a result, the environment will not be contaminated by waste oil.

3. Cost reduction

Saving the expense from oil loss and lubricating device.

4. Enables the most suitable oil for the purpose of use to be selected

The SL lubricator makes it possible to select the most proper lubricant for your application of linear guideway.

2. Performance

Lengthening the interval between maintenance works

By using the SL lubricator, the interval between maintenance work can be lengthened at all load rating.

Running Test without Replenishment of Lubricant

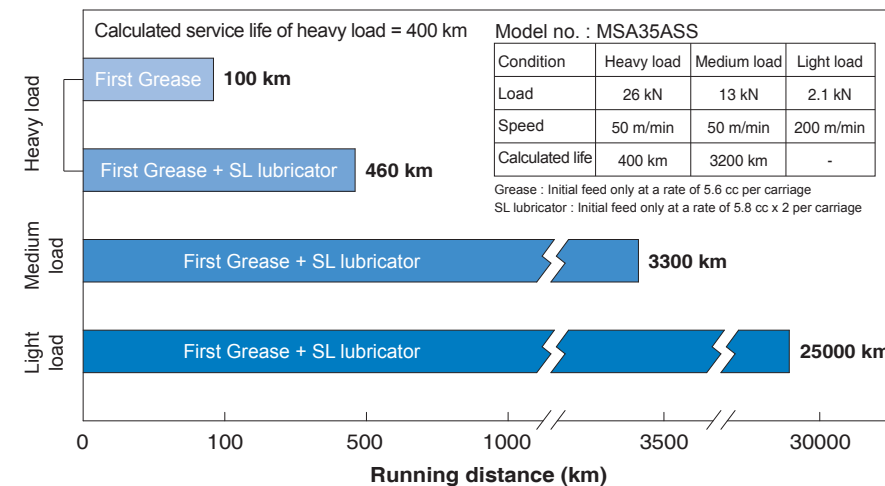

Effective use of lubricant

Since only the needed amount of lubricant will be applied to needed location, thereby effective use of lubricant can be achieved and the waste of lubricant can also be avoided.

Annual Lubricant Consumption per Carriage

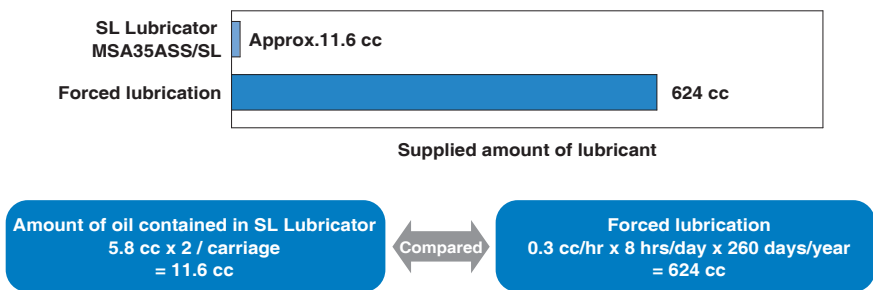

3. Description of Specification

(1) Non-Interchangeable Type

	MSA25 A 2 SS FO /SL + R 1200 -20 /40 P II
Model no.	MSA25 A
Carriage type	2
Number of carriages per rail	SS
Dust protection option	FO
Preload	/SL
Code of special carriage	+ R
SL lubricator	1200
Rail type	-20
rail length (mm)	/40
Rail hole pitch from start side	P
Rail hole pitch to the end side	II
Accuracy grade	
Code of special rail	
Number of rails per axis	

(2) Interchangeable Type Carriage

	MSA25 A SS FC N /SL
Model no.	MSA25 A
Carriage type	SS
Dust protection option	FC
Preload	N
Accuracy grade	/SL
Code of special carriage	
SL lubricator	

4. Dimensions of the SL Lubricator

MSA series

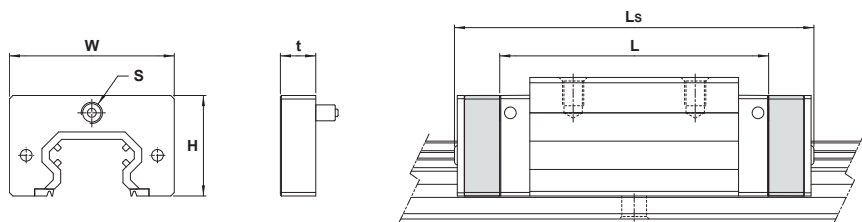

Model No.		SL Lubricator dimension (mm)				Carriage dimension (mm)	
		Height H	Width W	Thickness t	Tapped hole S	Standard length L	SL Lubricator overall length Ls
MSA 15SL	A/E/S	19	31.2	10	M4	56.3	81.3
MSA 20SL	A/E/S	21.2	42.8	10	M6	72.9	92.9
	LA/LE/LS					88.8	108.8
MSA 25SL	A/E/S	28.5	46.8	10	M6	81.6	101.6
	LA/LE/LS					100.6	120.6
MSA 30SL	A/E/S	32	57	10	M6	97	117
	LA/LE/LS					119.2	139.2
MSA 35SL	A/E/S	36.5	68	10	M6	111.2	131.2
	LA/LE/LS					136.6	156.6
MSA 45SL	A/E/S	49	83.6	15	1/8PT	137.7	167.7
	LA/LE/LS					169.5	199.5
MSA 55SL	A/E/S	53	97	15	1/8PT	161.5	191.5
	LA/LE/LS					199.5	229.5
MSA 65SL	A/E/S	67	120	15	1/8PT	199	229
	LA/LE/LS					253	283

Note*: Supply the Dust proof series(UU、SS、ZZ、LL、RR)

MSB series

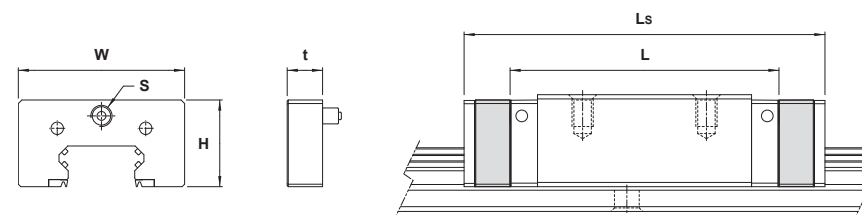

Model No.		SL Lubricator dimension (mm)				Carriage dimension (mm)	
		Height H	Width W	Thickness t	Tapped hole S	Standard length L	SL Lubricator overall length Ls
MSB 15SL	TE/TS	18.5	33	10	M4	40	65
	E/S					57	82
MSB 20SL	TE/TS	21.2	40.8	10	M6	48	68
	E/S					67	87
MSB 25SL	TE/TS	24.5	47	10	M6	60.2	80.2
	E/S					82	102
MSB 30SL	TE/TS	30.8	57	10	M6	68	88
	E/S					96.7	116.7
MSB 35SL	TE/TS	37	68.5	10	M6	78	98
	E/S					112	132
						137.5	157.5

Note*: Supply the Dust proof series(UU、SS、ZZ、LL、RR)

MSR series

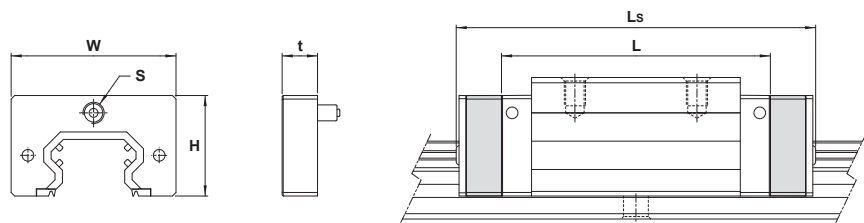

SMR series

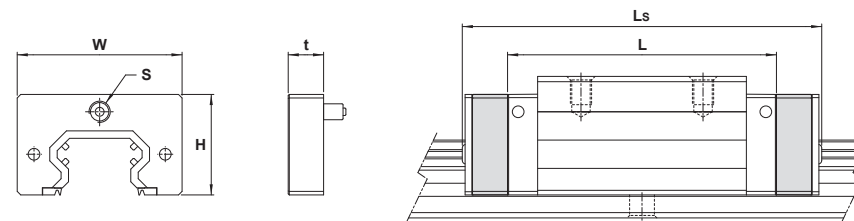

Model No.		SL Lubricator dimension (mm)				Carriage dimension (mm)	
		Height H	Width W	Thickness t	Tapped hole S	Standard length L	SL Lubricator overall length L _s
MSR 25SL	E/S	30.2	47	10	M6	97.5	117.5
	LE/LS					115.5	135.5
MSR 30SL	E/S	34.5	58.6	10	M6	112.4	132.4
	LE/LS					135.2	155.2
MSR 35SL	E/S	40.5	69	10.3	M6	125.3	145.9
	LE/LS					153.5	174.1
MSR 45SL	E/S	50.9	84	15.3	1/8PT	154.2	184.8
	LE/LS					189.4	220
MSR 55SL	E/S	58.5	98	15.3	1/8PT	185.4	216
	LE/LS					235.4	266
MSR 65SL	LE/LS	76.5	122	15	1/8PT	302	332

Model No.		SL Lubricator dimension (mm)				Carriage dimension (mm)	
		Height H	Width W	Thickness t	Tapped S	Standard length L	SL Lubricator overall length L _s
SMR 25SL	E/S	30.2	47	10	M6	97.5	117.5
	LE/LS					115.5	135.5
SMR 30SL	E/S	34.5	58.6	10	M6	112.4	132.4
	LE/LS					135.2	155.2
SMR 35SL	E/S	40.5	69	10.3	M6	125.3	145.9
	LE/LS					153.5	174.1
SMR 45SL	E/S	50.9	84	15.3	1/8PT	154.2	184.8
	LE/LS					189.4	220
SMR 55SL	E/S	58.5	98	15.3	1/8PT	185.4	216
	LE/LS					235.4	266
SMR 65SL	LE/LS	76.5	122	15	1/8PT	302	332

Note*: Supply the Dust proof series(UU \ SS \ ZZ)

Note*: Supply the Dust proof series(UU \ SS \ ZZ)

SME series

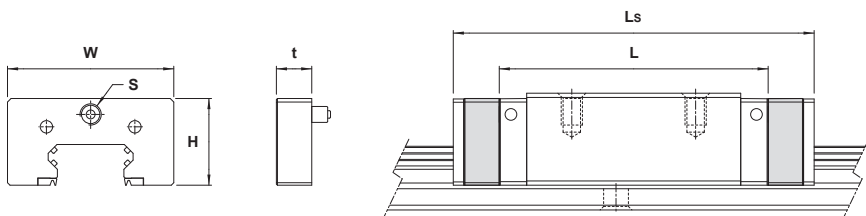

Model No.	SL Lubricator dimension (mm)				Carriage dimension (mm)		
	Height H	Width W	Thickness t	Tapped hole S	Standard length L	SL Lubricator overall length Ls	
SME 15SL	E/S	20.1	33.2	10	M4	64.4	84.4
	LE/LS					79.4	99.4
SME 20SL	E/S	22.8	41.4	10	M6	78.5	98.5
	LE/LS					97.5	117.5
SME 25SL	E/S	26.1	47.2	10	M6	92	112
	LE/LS					109	129
SME 30SL	E/S	33.5	58.5	10	M6	107.6	127.6
	LE/LS					132.6	152.6
SME 35SL	E/S	38.5	68	10	M6	120.6	140.6
	LE/LS					150.6	170.6
SME 45SL	E/S	49	83.6	15	1/8PT	140	170
	LE/LS					174.5	204.5

Note*: Supply the Dust proof series(UU、SS、ZZ)

B. Lubrication equipment - Grease gun

Grease gun used different nozzles installed on different oiling the supplementary grease.

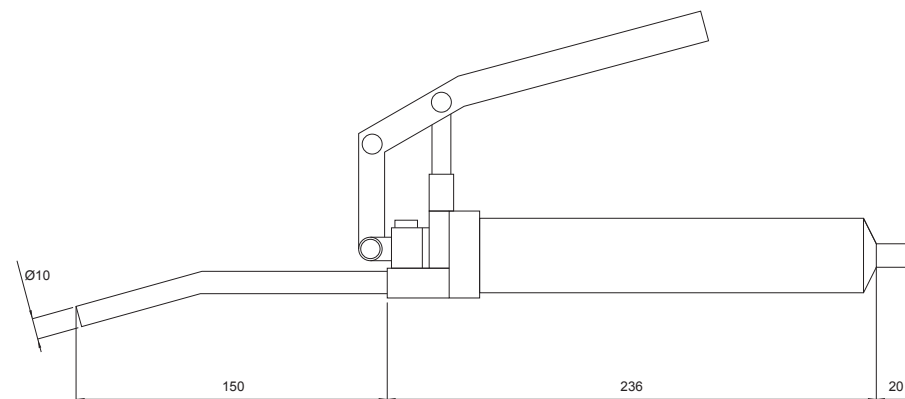

Size and working condition :

discharge pressure	15MPa
discharge rate	0.35g / stroke
weight (excluding the grease)	680g
overall length	about 400mm
width	about 120mm
outside diameter of nozzle	Φ10mm

C. Grease nipple and piping joint

Grease nipple

G-M6

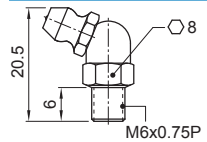

GS-M6

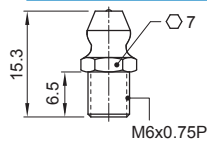

G-PT1/8

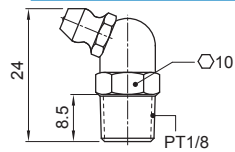

GS-PT1/8

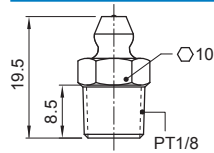

G-M4

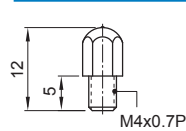

TS-A(Connect Fitting)

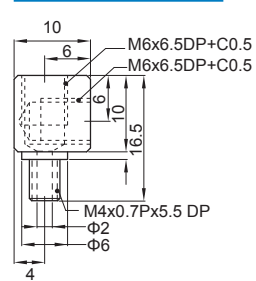

Oil piping joint

OL Type

OL-A

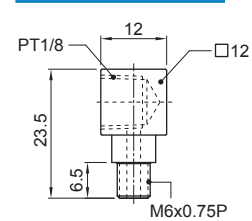

OL-B

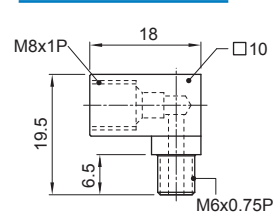

OL-C

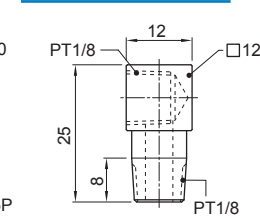

OL-D

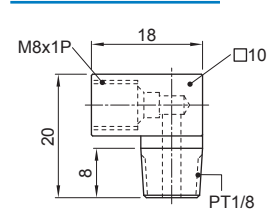

OL-E

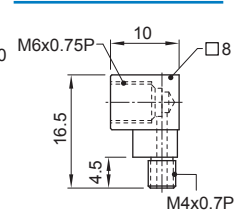

OS Type

OS-A

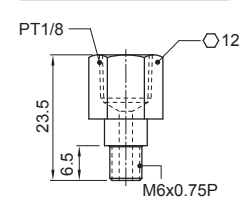

OS-B

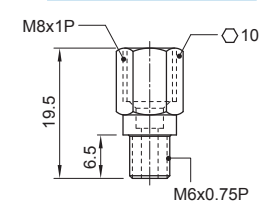

OS-C

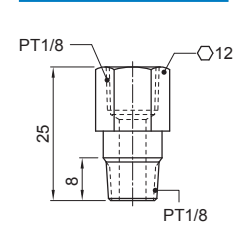

OS-D

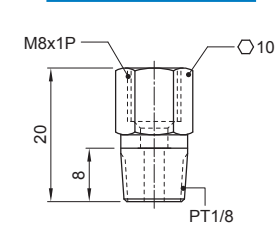

Model No.						Dust Proof Type							
						SS		DD		ZZ		KK	
MSA15	MSB15	SME15				G-M4	OL-E	G-M4L	OL-EL	G-M4L	OL-EL	G-M4L	OL-EL
MSA20	MSB20	SME20				G-M6	GS-M6	G-M6M	GS-M6M	G-M6M	GS-M6M	G-M6L	GS-M6L
MSA25	MSB25	SME25	SMR25	SMR25	MSG21	OL-A	OL-B	OL-AL	OL-BL	OL-AL	OL-BL	OL-AL	OL-BL
MSA30	MSB30	SME30	SMR30	SMR30	MSG27	OS-A	OS-B	OS-AL	OS-BL	OS-AL	OS-BL	OS-AL	OS-BL
MSA35	MSB35	SME35	SMR35	SMR35	MSG35								
MSA45		SME45	SMR45	SMR45		G-PT1/8	GS-PT1/8	G-PT1/8L	OL-DL	G-PT1/8L	OL-DL	G-PT1/8L	OL-DL
MSA55			SMR55	SMR55		OL-C	OL-D	OL-CL	OS-DL	OL-CL	OS-DL	OL-CL	OS-DL
MSA65			SMR65	SMR65		OS-C	OS-D	OS-CL		OS-CL		OS-CL	

Note:1.MSA15-ZZ and MSA15-DD use the nipple"G-M4"

2.When MSB15 use the nipple "OL-E", change the nipple to "OL-EL"

D. The Relationship between the Direction of Lubrication and the Reference Side

The standard lubrication fitting is grease nipple (G-M6、G-PT1/8、G-M4). The code of different types of application for lubrication fittings are shown below. For cases other than specified, please contact us for confirmation.

The relationship between the direction of lubrication and the reference side

Code: C1R1

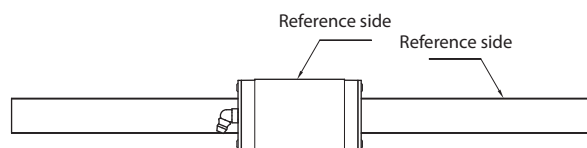

Code: C1R2

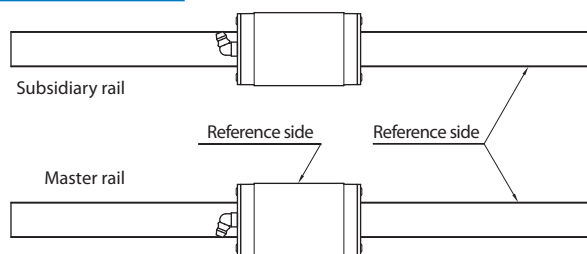

Code: C2R1

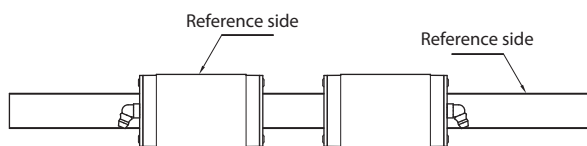

Code: C2R2

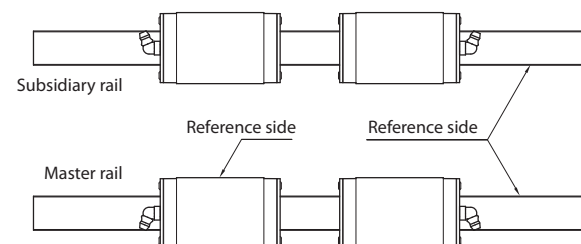

Code: C3R1

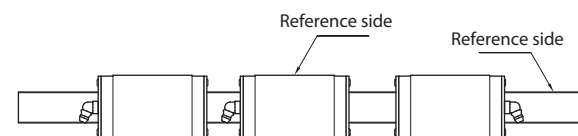

Code: C3R2

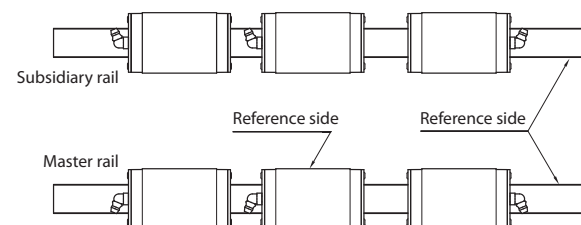

Code: C4R1

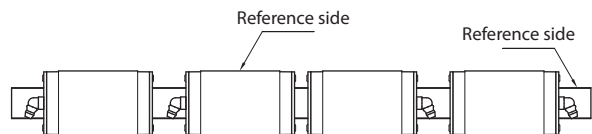

Code: C4R2

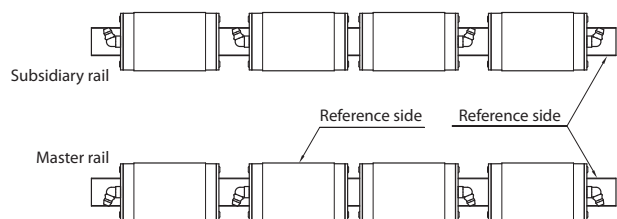

Lubrication location

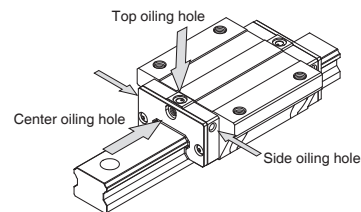

Lateral usage (Adapter only for MSA and MSB series)

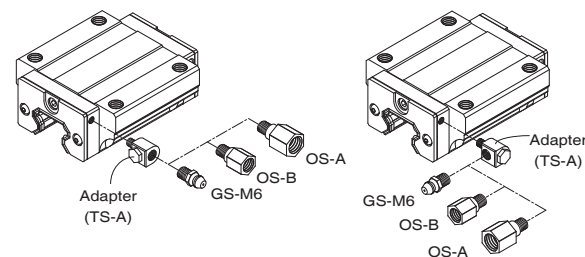

E. Lubrication position

The standard mounting locating of carriage is at the center of both ends. As for lateral and top application, please specify when ordering. As shown as below, the lateral application is achieved by using an adapter to connect the grease/oil fitting to the hole on the carriage.

Model No.		Center	Side	
		Nipple	G1	Nipple
MSA 15	MSB 15	G-M4	M4×0.7P	G-M4
MSA 20	MSB 20	G-M6	M4×0.7P	G-M4
MSA 25	MSB 25	G-M6	M4×0.7P	G-M4
MSA 30	MSB 30	G-M6	M4×0.7P	G-M4
MSA 35	MSB 35	G-M6	M4×0.7P	G-M4
MSA 45		G-PT1/8	M4×0.7P	G-M4
MSA 55		G-PT1/8	M4×0.7P	G-M4
MSA 65		G-PT1/8	M4×0.7P	G-M4

Note: MSA and MSB series have no top oiling hole for option.

16 Precautions of Linear Guideway

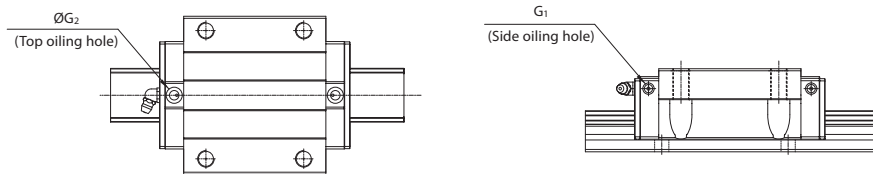

Model No.	Center	Side		Top	
	Nipple	G ₁	Nipple	G ₂	O-ring
SME 15	G-M4	M4×0.7P	G-M4	-	-
SME 20	G-M6	M4×0.7P	G-M4	-	-
SME 25	G-M6	M4×0.7P	G-M4	-	-
SME 30	G-M6	M6×0.75P	G-M6	10.2	P7
SME 35	G-M6	M6×0.75P	G-M6	10.2	P7
SME 45	G-PT1/8	M6×0.75P	G-M6	10.2	P7

Model No.	Center	Side		Top		
	Nipple	G ₁	Nipple	G ₂	O-ring	
SMR 25	MSR 25	G-M6	M6×0.75P	G-M6	10.2	P7
SMR 30	MSR 30	G-M6	M6×0.75P	G-M6	10.2	P7
SMR 35	MSR 35	G-M6	M6×0.75P	G-M6	10.2	P7
SMR 45	MSR 45	G-PT1/8	M6×0.75P	G-M6	10.2	P7
SMR 55	MSR 55	G-PT1/8	M6×0.75P	G-M6	10.2	P7
SMR 65	MSR 65	G-PT1/8	M6×0.75P	G-M6	10.2	P7

Model No.	Center	Side		Top	
	Nipple	G ₁	Nipple	G ₂	O-ring
MSG 21	G-M6	M4×0.7P	G-M4	-	-
MSG 27	G-M6	M4×0.7P	G-M4	6.1	P3
MSG 35	G-M6	M4×0.7P	G-M4	7.3	P4

Handling

1. Tilting the linear guideway may cause the carriage falling out from the rail by their own weight.
2. Beating or Dropping the linear guideway may cause its function to be damage, even if the product looks intact.
3. Do not disassemble the carriage, this may cause contamination to enter into the carriage or decrease the installation accuracy.
4. Carrying excessive weight for linear guideway, by two or more people or handling equipment, to avoid causing personal injury or damage of the workpiece possibly.
5. Note that to prevent foreign material and foreign body, causing the slider failure, damage and loss of function.

Lubrication

1. Please remove the anti-rust oil in advance and lubricate it before using.
2. Do not mix lubricants with others.
3. If you are using oil as lubricant, the oil may not be distributed evenly to the ball groove that depending on the application of the mounting orientation. Please contact **PMI** in such case.
4. Moving the carriage back and forth with minimum stroke length of length of 3 carriages after the carriages been greased. To assure the grease is evenly distributed inside of carriage, the mentioned process should be repeated twice at least.

Using

1. The temperature of the place where linear guideways are used should not exceed 80°C. A higher temperature may damage the plastic end cap.
2. If the carriage must be removed from the rail or remounted onto the rail, be sure to use the dummy rail.
3. Using under special conditions, such as constant vibration, high dust or the temperature exceed our suggested...etc., please contact **PMI**.

Storage

When storing the linear guideway, enclose it in a package and store it in a horizontal orientation while avoiding high temperature, low temperature and high humidity.

