

ACCU TECH USA

Automation and Motion Solutions



UNIMOTION

WE MAKE THING SIMPLE

At Accu Tech USA, our focus is simple. Our customer's success is our priority. Our team stands ready to support you through product selection, sales and support.

NEVER COMPROMISE ON QUALITY

We work with our partners to provide quality products that perform as expected to ensure we exceed your expectations.

ON TIME. ON BUDGET.

Accu Tech USA is the value leader for automation solutions in North America. We deliver products on time and on budget to increase your ROI.



PNCE

The PNCE electric cylinder combines the strength and precision of a ball screw actuator in an ISO 15552 package making it an effective option for many applications. The improved efficiency and flexibility of an electric system as well as the ability to use standard ISO accessories are of great benefit for those looking to move away from pneumatic systems. The PNCE is available with a multitude of options including male or female rod-ends, upgraded seal options, and corrosion resistant version and accessories.

Features:

- 6 Frame Sizes (32, 40, 50, 63, 80, 100)
- Custom Stroke Lengths
- Ball Screw Lead Options From 5mm to 50mm
- High Precision, Low Backlash
- IP54 Rated. IP65, Corrosion Resistant and Food Industry Versions Available
- Wide Range of ISO 15552 Compatible Accessories
- In-line or Parallel Motor Mounting



CTV

Accu Tech USA's CTV series, from UniMotion, features a precision ball screw drive and pair of linear guides making it a powerful, precise, and long lasting actuator in a compact package. From the smallest frame size to the largest, the low profile and flexible mounting options make it an easy fit in many single or multi-axis applications. The CTV is available with an optional T-slot connecting plate, polyurethane or stainless steel coverstrips, and in-line or parallel motor mounts.

Features:

- 4 Frame Sizes (90, 110, 145, 200)
- Custom Stroke Lengths
- Ball Screw Lead Options From 5mm to 50mm
- Long or Short Slider Versions With or Without Connection Plate
- Polyurethane or Stainless Steel Cover Strips
- In-line or Parallel Motor Mounting
- Ground Ball Screw Available

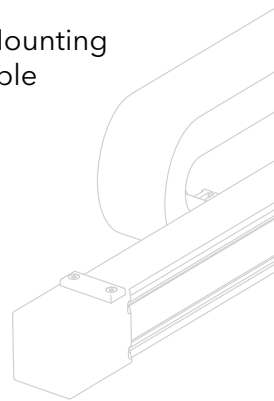
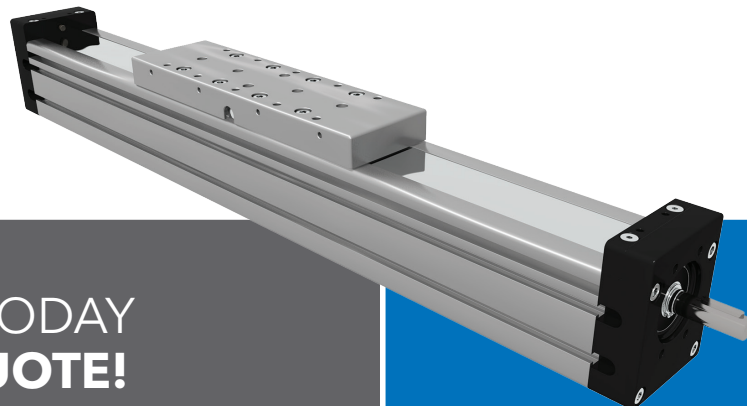

CONTACT US TODAY
REQUEST A QUOTE!

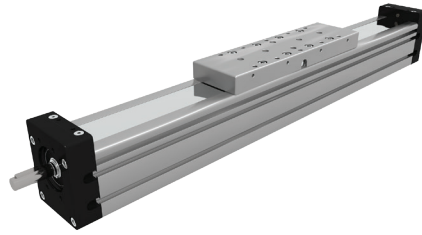

MTV

The MTV series ball screw actuator strikes a great balance between price and performance and is able to meet the requirements of high-precision and high-thrust applications of many kinds. Available sliding ball screw supports even allow the MTV to work in high-speed or long-stroke applications where standard ball screw actuators won't. The MTV is also available with optional holes for adding pneumatic fittings and with opposing motion sliders, making it an excellent choice for clamping applications.

Features:

- 3 Frame Sizes (65, 80, 110)
- Custom Stroke Lengths
- Ball Screw Leads From 5mm to 50mm
- Opposing Motion - Left Hand/Right Hand Ball Screw Version Available
- Multiple Sliding Ball Screw Supports Option
- In-line or Parallel Motor Mounting
- Ground Ball Screw Available

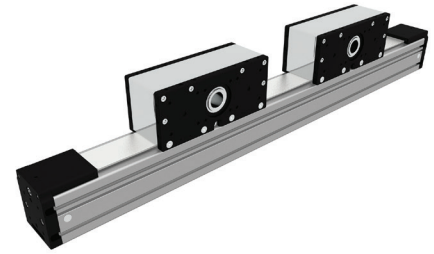

MTJ/CTJ

The MTJ and CTJ belt actuator series can meet the requirements for demanding high speed and long stroke length applications with strength and precision. Single (MTJ) or dual (CTJ) linear guides provide rigidity while a steel-reinforced polyurethane belt drives the actuator with high repeatability. For even higher speed applications the MRJ version actuator swaps the standard linear guide for v-rollers allowing for maximum speed - up to 10m/s. Both the MTJ and CTJ are available with through-bore, single side, or dual left/right side drives.

Features:

- 4 MTJ Frame Sizes (40, 65, 80, 110)
- 4 CTJ Frame Sizes (90, 110, 145, 200)
- Custom Stroke Lengths
- Short and Long Slider Versions
- MTJ 40 ECO for Small Payload, Low-Cost Applications
- Roller Guide Option (MRJ)
- Stainless Steel Cover Strip Option

- SEMI CONDUCTOR
- WOOD WORKING
- CNC MACHINE TOOL

- MEDICAL LIFE SCIENCES
- PACKAGING & CONVERTING
- FACTORY AUTOMATION

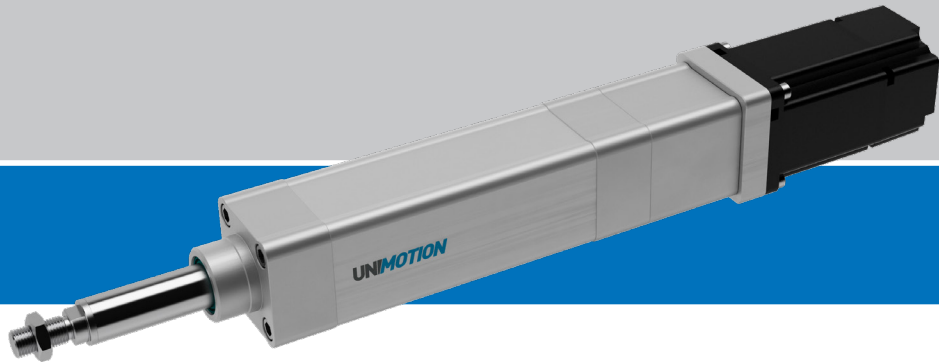

Contact Us Today

Need help with an active project? Do you need Sizing/Selection Tools to quickly size the right product? Our team of experienced design engineering, application engineering and custom machining technicians are ready to assist you in the design, selection and implementation of your project.

ACCU TECH USA

Automation and Motion Solutions

12339 Wake Union Church Road, Suite 110
Wake Forest, NC 27587
919.863.0837
sales@accu-techusa.com

www.accu-techusa.com

