

Y50

1-axis

Ball Screw Drive



Maximum Stroke **300mm**

Maximum Speed **500mm/s**

Motor Output **100W**

Ball Screw $\phi 12\text{ mm}$

Ordering Method

Y50-L 5-100-BC-M 10 B-C 4-0001

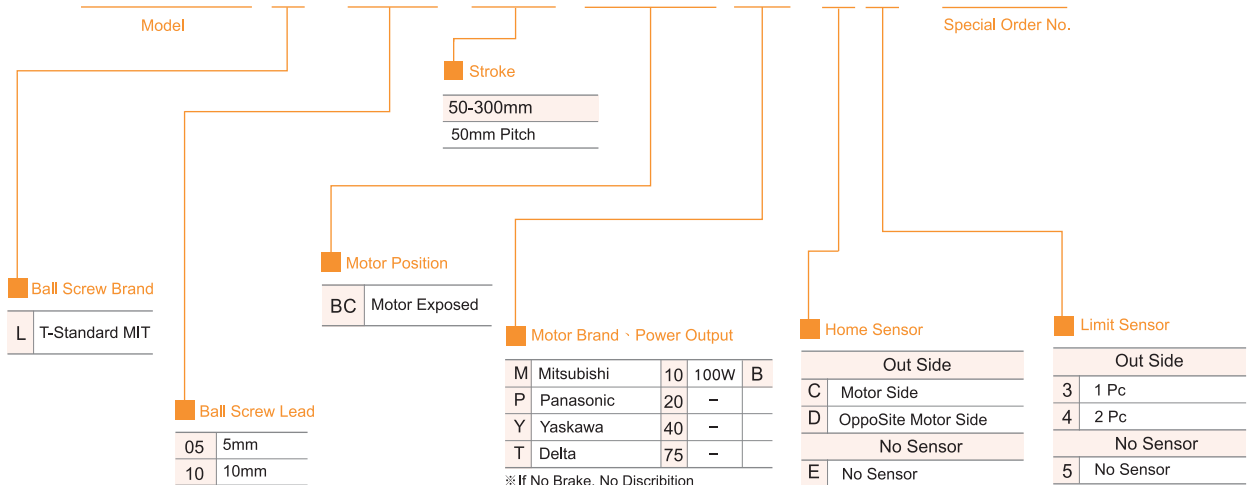

Specification

Function	Repeatability (mm)		±0.01	
	Lead (mm)		5	10
	Maximum Speed (mm/s)		250	500
	Maximum Payload	Horizontal (kg)	30	15
		Vertical (kg)	12	5
	Rated Thrust (N)		341	170
	Stroke Pitch (mm)		50-300mm / 50mm Pitch	
Parts	AC Servo Motor Output (w)		100	
	Ball Screw Ø (mm)		C7 φ 12	
	Coupling (mm)		7X8	
	Home Sensor	Outside	CS-6T	

Sensor Layout

General load : Such as relay or other resistive load

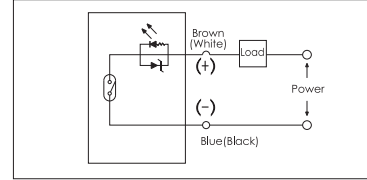

Programmable controller connection diagram

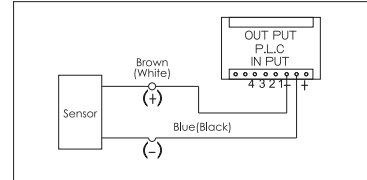

Y50 Size



Welcome to download 2D/3D CAD and spec PDF

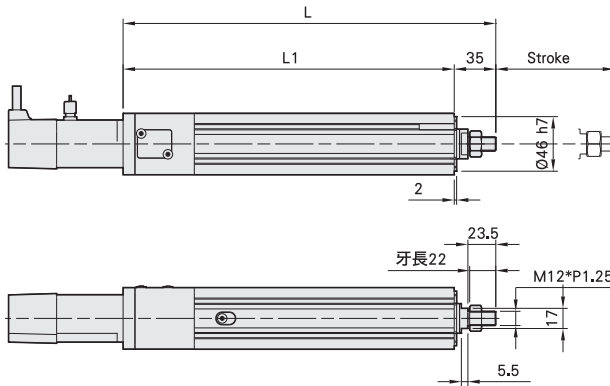

Stroke	50	100	150	200	250	300
L	264	314	364	414	464	514
L 1	229	279	329	379	429	479
KG	2.12	2.38	2.64	2.9	3.17	3.34

Suitable Motor Brand

Brand	Mark	Brake	Wattp	AC-Voltage	Motor Model	Driver Model
Mitsubishi	M	No Brake (Horizontal Type)	100	220	HF-KP13	MR-J3-10A
		With Brake (Vertical Type)	100	220	HF-KP13B	MR-J3-10A
Panasonic	P	No Brake (Horizontal Type)	100	220	MSMD012P1S	MADDT1205
		With Brake (Vertical Type)	100	220	MSMD012P1T	MADDT1205
Delta	T	No Brake (Horizontal Type)	100	220	ECMA-C20401ES	ASD-B20121-B
		With Brake (Vertical Type)	100	220	ECMA-C20401FS	ASD-B20121-B