

ETB22M

1-axis

Belt Drive



Maximum Stroke **4050mm** Maximum Speed **2000mm/s** Motor Output **750W** Ball Screw **50 mm** Linear Guide **23X18-2支**

Ordering Method

ETB22M-L 40 - 100 - L - M 75 - C 4 - 0001

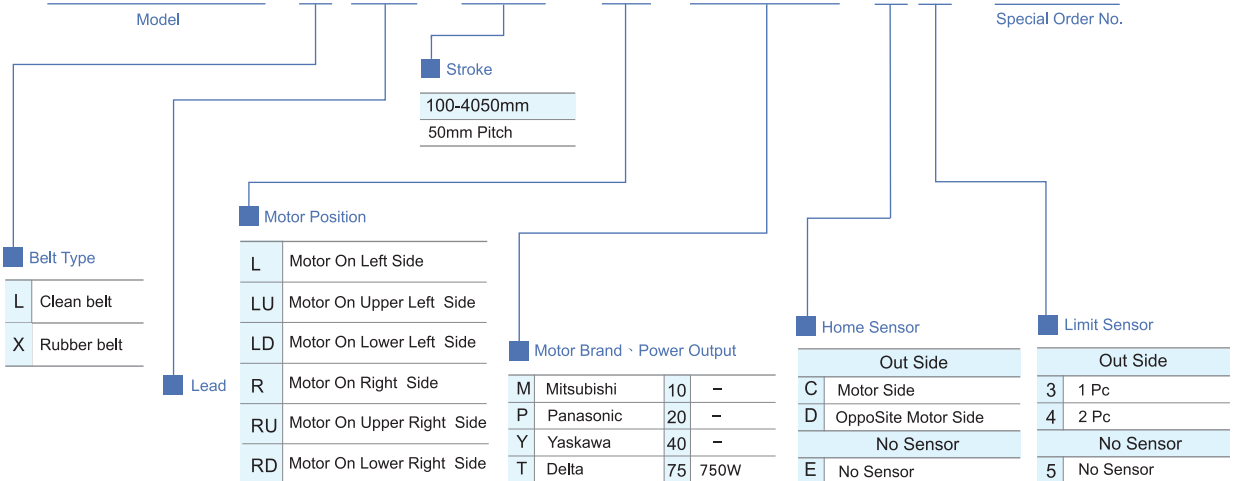

Toll-Free Number : China 400-875-0009 Taiwan 0800-800-893

Specification

Function	Repeatability (mm)		±0.04
	Lead (mm)		40
	Maximum Speed (mm/s)		2000
	Maximum Payload	Horizontal (kg)	85
		Vertical (kg)	
	Rated Thrust (N)		367
Stroke Pitch (mm)		100-4050mm / 50mm Pitch	
Parts	AC Servo Motor Output (w)		750
	Belt Width		50
	High Rigidity Linear Guide (mm)		23X18
	Home Sensor	Outside	EE-SX672(NPN)

Sensor Layout

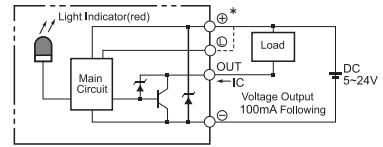

Allowable Overhang N.m

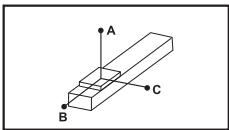

(Unit:mm)

Horizontal Installation	A	B	C
45kg	3444	1015	1358
65kg	2460	725	970
85kg	1892	558	746

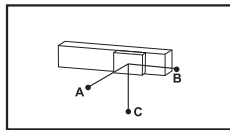

(Unit:mm)

Wall Installation	A	B	C
45kg	1414	928	3437
65kg	1010	663	2455
85kg	777	510	1888

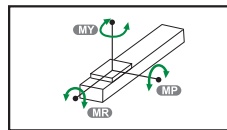

(Unit:mm)

Static Loading Moment

MY	2052(N)
MP	2052(N)
MR	1810(N)

Suitable Motor Brand

Brand	Mark	Brake	Watp	AC-Voltage	Motor Model	Driver Model
Mitsubishi	M	No Brake (Horizontal Type)	750	220	HF-KP73	MR-J3-70A
Panasonic	P	No Brake (Horizontal Type)	750	220	MHMD082P1S	MCDDT3520
Delta	T	No Brake (Horizontal Type)	750	220	ECMA-C20807ES	ASD-B20721-B

Application
Standard/Belt Screw
Rod Type Actuator
Standard/Belt Type
Clean Room/Belt Screw
Clean Room/Belt Type
Linear Motor
Multi Axis
Alignment Stage
Reference

1 axis
ETB
ETB5
ETB6
ETB10
ETB14M
ETB17M
ETB22M

ETB22M 1-axis

Motor On Left Side / Motor On Right Side

L Motor On Left Side



Welcome to download 2D/3D CAD and spec PDF

(mm)

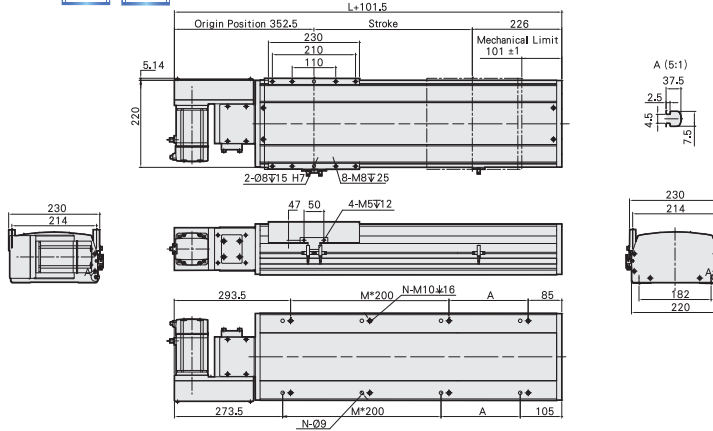

Stroke	100	150	200	250	300	350	400	450	500	550	600	650	700	750	800	850	900	950	1000	1050	1100	1150	1200	1250	1300	1350	1400	1450	1500	1550
L	577	627	677	727	777	827	877	927	977	1027	1077	1127	1177	1227	1277	1327	1377	1427	1477	1527	1577	1627	1677	1727	1777	1827	1877	1927	1977	2027
A	100	150	200	50	100	150	200	50	100	150	200	50	100	150	200	50	100	150	200	50	100	150	200	50	100	150	200	50	100	150
M	1	1	1	2	2	2	2	3	3	3	3	4	4	4	4	5	5	5	5	6	6	6	6	7	7	7	7	8	8	8
N	6	6	6	8	8	8	8	10	10	10	10	10	12	12	12	14	14	14	14	16	16	16	16	18	18	18	18	20	20	20
KG	12	13.8	14.6	15.4	16.1	16.9	17.7	18.5	19.2	20	20.8	21.6	22.3	23.1	23.9	24.7	25.4	26.2	27	27.8	28.6	29.4	30.2	31	31.8	32.6	33.4	34.2	35	35.8

Stroke	1600	1650	1700	1750	1800	1850	1900	1950	2000	2050	2100	2150	2200	2250	2300	2350	2400	2450	2500	2550	2600	2650	2700	2750	2800	2850	2900	2950	3000	3050
L	2077	2127	2177	2227	2277	2327	2377	2427	2477	2527	2577	2627	2677	2727	2777	2827	2877	2927	2977	3027	3077	3127	3177	3227	3277	3327	3377	3427	3477	3527
A	200	50	100	150	200	50	100	150	200	50	100	150	200	50	100	150	200	50	100	150	200	50	100	150	200	50	100	150	200	50
M	8	9	9	9	9	10	10	10	10	10	11	11	11	11	12	12	12	12	13	13	13	13	14	14	14	14	15	15	15	16
N	20	22	22	22	22	24	24	24	24	24	26	26	26	26	28	28	28	28	30	30	30	30	32	32	32	32	34	34	34	36
KG	36.6	37.4	38.2	39	39.8	40.6	41.4	42.2	43	43.8	44.6	45.4	46.2	47	47.8	48.6	49.4	50.2	51	51.8	52.6	53.4	54.2	55	55.8	56.6	57.4	58.2	59	59.8

R Motor On Right Side



Welcome to download 2D/3D CAD and spec PDF

(mm)

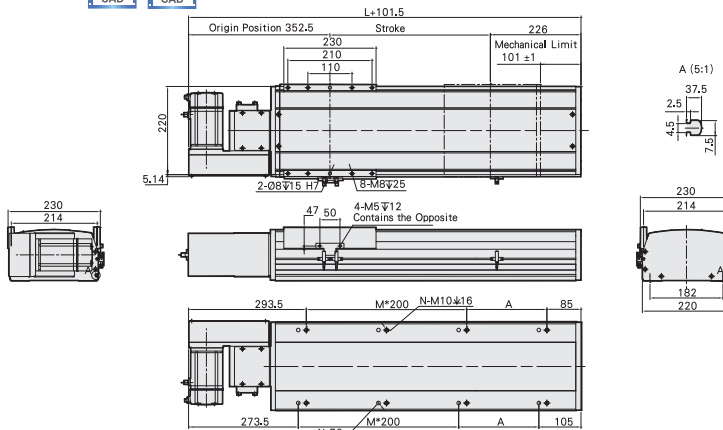

Stroke	100	150	200	250	300	350	400	450	500	550	600	650	700	750	800	850	900	950	1000	1050	1100	1150	1200	1250	1300	1350	1400	1450	1500	1550
L	577	627	677	727	777	827	877	927	977	1027	1077	1127	1177	1227	1277	1327	1377	1427	1477	1527	1577	1627	1677	1727	1777	1827	1877	1927	1977	2027
A	100	150	200	50	100	150	200	50	100	150	200	50	100	150	200	50	100	150	200	50	100	150	200	50	100	150	200	50	100	150
M	1	1	1	2	2	2	2	3	3	3	3	4	4	4	4	5	5	5	5	6	6	6	6	7	7	7	7	8	8	8
N	6	6	6	8	8	8	8	10	10	10	10	12	12	12	12	14	14	14	14	16	16	16	16	18	18	18	18	20	20	20
KG	12	13.8	14.6	15.4	16.1	16.9	17.7	18.5	19.2	20	20.8	21.6	22.3	23.1	23.9	24.7	25.4	26.2	27	27.8	28.6	29.4	30.2	31	31.8	32.6	33.4	34.2	35	35.8

Stroke	1600	1650	1700	1750	1800	1850	1900	1950	2000	2050	2100	2150	2200	2250	2300	2350	2400	2450	2500	2550	2600	2650	2700	2750	2800	2850	2900	2950	3000	3050
L	2077	2127	2177	2227	2277	2327	2377	2427	2477	2527	2577	2627	2677	2727	2777	2827	2877	2927	2977	3027	3077	3127	3177	3227	3277	3327	3377	3427	3477	3527
A	200	50	100	150	200	50	100	150	200	50	100	150	200	50	100	150	200	50	100	150	200	50	100	150	200	50	100	150	200	50
M	8	9	9	9	9	10	10	10	10	10	11	11	11	11	12	12	12	12	13	13	13	13	14	14	14	14	15	15	15	16
N	20	22	22	22	22	24	24	24	24	24	26	26	26	26	28	28	28	28	30	30	30	30	32	32	32	32	34	34	34	36
KG	36.6	37.4	38.2	39	39.8	40.6	41.4	42.2	43	43.8	44.6	45.4	46.2	47	47.8	48.6	49.4	50.2	51	51.8	52.6	53.4	54.2	55	55.8	56.6	57.4	58.2	59	59.8

Motor On Lower Left Side /
Motor On Lower Right Side

Toll-Free Number : China 400-875-0009 Taiwan 0800-800-893

LD Motor On Lower Left Side



Welcome to download 2D/3D CAD and spec PDF

(mm)

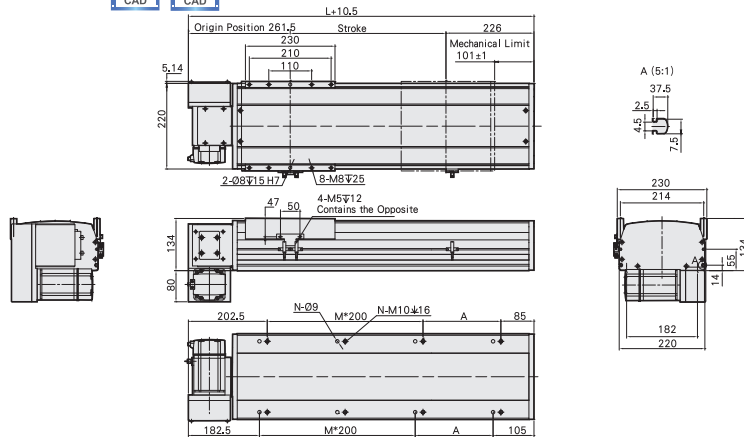

Stroke	100	150	200	250	300	350	400	450	500	550	600	650	700	750	800	850	900	950	1000	1050	1100	1150	1200	1250	1300	1350	1400	1450	1500	1550
L	577	627	677	727	777	827	877	927	977	1027	1077	1127	1177	1227	1277	1327	1377	1427	1477	1527	1577	1627	1677	1727	1777	1827	1877	1927	1977	2027
A	100	150	200	50	100	150	200	50	100	150	200	50	100	150	200	50	100	150	200	50	100	150	200	50	100	150	200	50	100	150
M	1	1	1	2	2	2	2	3	3	3	3	4	4	4	4	5	5	5	5	6	6	6	6	7	7	7	7	8	8	8
N	6	6	6	8	8	8	8	10	10	10	10	12	12	12	12	14	14	14	14	16	16	16	16	18	18	18	18	20	20	20
KG	12	13.8	14.6	15.4	16.1	16.9	17.7	18.5	19.2	20	20.8	21.6	22.3	23.1	23.9	24.7	25.4	26.2	27	27.8	28.6	29.4	30.2	31	31.8	32.6	33.4	34.2	35	35.8

Stroke	1600	1650	1700	1750	1800	1850	1900	1950	2000	2050	2100	2150	2200	2250	2300	2350	2400	2450	2500	2550	2600	2650	2700	2750	2800	2850	2900	2950	3000	3050
L	2077	2127	2177	2227	2277	2327	2377	2427	2477	2527	2577	2627	2677	2727	2777	2827	2877	2927	2977	3027	3077	3127	3177	3227	3277	3327	3377	3427	3477	3527
A	200	50	100	150	200	50	100	150	200	50	100	150	200	50	100	150	200	50	100	150	200	50	100	150	200	50	100	150	200	50
M	8	9	9	9	9	10	10	10	10	11	11	11	11	12	12	12	12	13	13	13	13	14	14	14	14	15	15	15	15	16
N	20	22	22	22	22	24	24	24	24	26	26	26	26	28	28	28	28	30	30	30	30	32	32	32	32	34	34	34	34	36
KG	36.6	37.4	38.2	39	39.8	40.6	41.4	42.2	43	43.8	44.6	45.4	46.2	47	47.8	48.6	49.4	50.2	51	51.8	52.6	53.4	54.2	55	55.8	56.6	57.4	58.2	59	59.8

RD Motor On Lower Right Side



Welcome to download 2D/3D CAD and spec PDF

(mm)

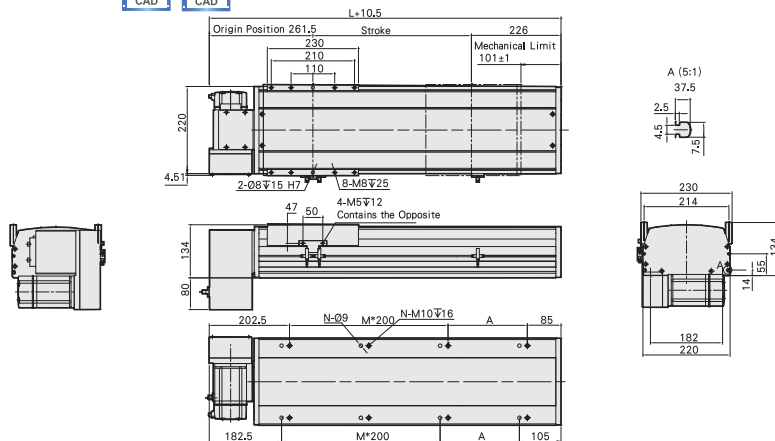

Stroke	100	150	200	250	300	350	400	450	500	550	600	650	700	750	800	850	900	950	1000	1050	1100	1150	1200	1250	1300	1350	1400	1450	1500	1550
L	577	627	677	727	777	827	877	927	977	1027	1077	1127	1177	1227	1277	1327	1377	1427	1477	1527	1577	1627	1677	1727	1777	1827	1877	1927	1977	2027
A	100	150	200	50	100	150	200	50	100	150	200	50	100	150	200	50	100	150	200	50	100	150	200	50	100	150	200	50	100	150
M	1	1	1	2	2	2	2	3	3	3	3	4	4	4	4	5	5	5	5	6	6	6	6	7	7	7	7	8	8	8
N	6	6	6	8	8	8	8	10	10	10	10	12	12	12	12	14	14	14	14	16	16	16	16	18	18	18	18	20	20	20
KG	12	13.8	14.6	15.4	16.1	16.9	17.7	18.5	19.2	20	20.8	21.6	22.3	23.1	23.9	24.7	25.4	26.2	27	27.8	28.6	29.4	30.2	31	31.8	32.6	33.4	34.2	35	35.8

Stroke	1600	1650	1700	1750	1800	1850	1900	1950	2000	2050	2100	2150	2200	2250	2300	2350	2400	2450	2500	2550	2600	2650	2700	2750	2800	2850	2900	2950	3000	3050
L	2077	2127	2177	2227	2277	2327	2377	2427	2477	2527	2577	2627	2677	2727	2777	2827	2877	2927	2977	3027	3077	3127	3177	3227	3277	3327	3377	3427	3477	3527
A	200	50	100	150	200	50	100	150	200	50	100	150	200	50	100	150	200	50	100	150	200	50	100	150	200	50	100	150	200	50
M	8	9	9	9	9	10	10	10	10	11	11	11	11	12	12	12	12	13	13	13	13	14	14	14	14	15	15	15	15	16
N	20	22	22	22	22	24	24	24	24	26	26	26	26	28	28	28	28	30	30	30	30	32	32	32	32	34	34	34	34	36
KG	36.6	37.4	38.2	39	39.8	40.6	41.4	42.2	43	43.8	44.6	45.4	46.2	47	47.8	48.6	49.4	50.2	51	51.8	52.6	53.4	54.2	55	55.8	56.6	57.4	58.2	59	59.8

- 1 axis ETB
- ETB5
- ETB6
- ETB10
- ETB14M
- ETB17M
- ETB22M

ETB22M 1-axis

Motor On Upper Left Side /
Motor On Upper Right Side

LU Motor On Upper Left Side



Welcome to download 2D/3D CAD and spec PDF

(mm)

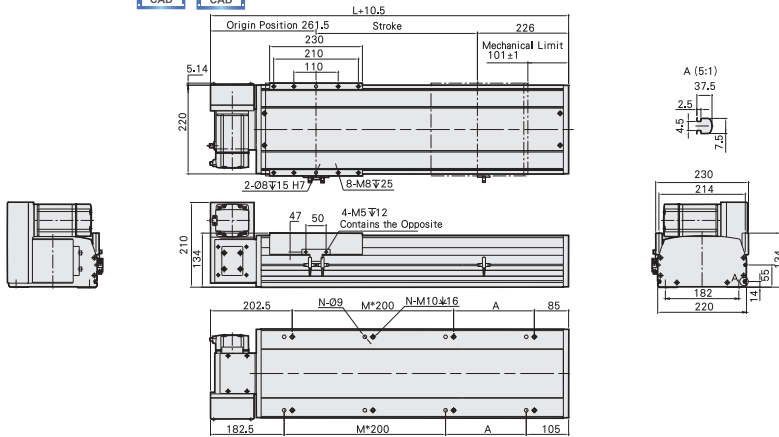

Stroke	100	150	200	250	300	350	400	450	500	550	600	650	700	750	800	850	900	950	1000	1050	1100	1150	1200	1250	1300	1350	1400	1450	1500	1550
L	577	627	677	727	777	827	877	927	977	1027	1077	1127	1177	1227	1277	1327	1377	1427	1477	1527	1577	1627	1677	1727	1777	1827	1877	1927	1977	2027
A	100	150	200	50	100	150	200	50	100	150	200	50	100	150	200	50	100	150	200	50	100	150	200	50	100	150	200	50	100	150
M	1	1	1	2	2	2	2	3	3	3	3	4	4	4	4	5	5	5	5	6	6	6	6	7	7	7	7	8	8	8
N	6	6	6	8	8	8	8	10	10	10	10	12	12	12	12	14	14	14	14	16	16	16	16	18	18	18	18	20	20	20
KG	12	13.8	14.6	15.4	16.1	16.9	17.7	18.5	19.2	20	20.8	21.6	22.3	23.1	23.9	24.7	25.4	26.2	27	27.8	28.6	29.4	30.2	31	31.8	32.6	33.4	34.2	35	35.8

Stroke	1600	1650	1700	1750	1800	1850	1900	1950	2000	2050	2100	2150	2200	2250	2300	2350	2400	2450	2500	2550	2600	2650	2700	2750	2800	2850	2900	2950	3000	3050
L	2077	2127	2177	2227	2277	2327	2377	2427	2477	2527	2577	2627	2677	2727	2777	2827	2877	2927	2977	3027	3077	3127	3177	3227	3277	3327	3377	3427	3477	3527
A	200	50	100	150	200	50	100	150	200	50	100	150	200	50	100	150	200	50	100	150	200	50	100	150	200	50	100	150	200	50
M	8	9	9	9	9	10	10	10	10	11	11	11	11	12	12	12	12	13	13	13	13	14	14	14	14	15	15	15	15	16
N	20	22	22	22	24	24	24	24	24	26	26	26	26	28	28	28	28	29	30	30	30	30	32	32	32	32	34	34	34	36
KG	36.6	37.4	38.2	39	39.8	40.6	41.4	42.2	43	43.8	44.6	45.4	46.2	47	47.8	48.6	49.4	50.2	51	51.8	52.6	53.4	54.2	55	55.8	56.6	57.4	58.2	59	59.8

RU Motor On Upper Right Side



Welcome to download 2D/3D CAD and spec PDF

(mm)

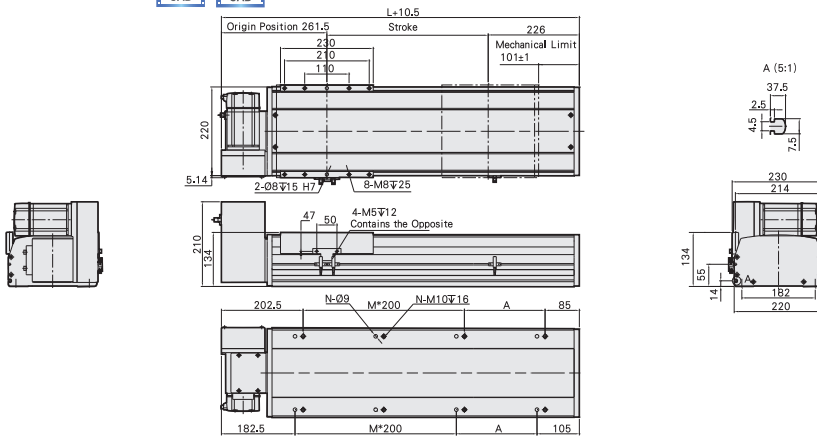

Stroke	100	150	200	250	300	350	400	450	500	550	600	650	700	750	800	850	900	950	1000	1050	1100	1150	1200	1250	1300	1350	1400	1450	1500	1550
L	577	627	677	727	777	827	877	927	977	1027	1077	1127	1177	1227	1277	1327	1377	1427	1477	1527	1577	1627	1677	1727	1777	1827	1877	1927	1977	2027
A	100	150	200	50	100	150	200	50	100	150	200	50	100	150	200	50	100	150	200	50	100	150	200	50	100	150	200	50	100	150
M	1	1	1	2	2	2	2	3	3	3	3	4	4	4	4	5	5	5	5	6	6	6	6	7	7	7	7	8	8	8
N	6	6	6	8	8	8	8	10	10	10	10	12	12	12	12	14	14	14	14	16	16	16	16	18	18	18	18	20	20	20
KG	12	13.8	14.6	15.4	16.1	16.9	17.7	18.5	19.2	20	20.8	21.6	22.3	23.1	23.9	24.7	25.4	26.2	27	27.8	28.6	29.4	30.2	31	31.8	32.6	33.4	34.2	35	35.8

Stroke	1600	1650	1700	1750	1800	1850	1900	1950	2000	2050	2100	2150	2200	2250	2300	2350	2400	2450	2500	2550	2600	2650	2700	2750	2800	2850	2900	2950	3000	3050
L	2077	2127	2177	2227	2277	2327	2377	2427	2477	2527	2577	2627	2677	2727	2777	2827	2877	2927	2977	3027	3077	3127	3177	3227	3277	3327	3377	3427	3477	3527
A	200	50	100	150	200	50	100	150	200	50	100	150	200	50	100	150	200	50	100	150	200	50	100	150	200	50	100	150	200	50
M	8	9	9	9	9	10	10	10	10	11	11	11	11	12	12	12	12	13	13	13	13	14	14	14	14	15	15	15	15	16
N	20	22	22	22	24	24	24	24	24	26	26	26	26	28	28	28	28	29	30	30	30	30	32	32	32	32	34	34	34	36
KG	36.6	37.4	38.2	39	39.8	40.6	41.4	42.2	43	43.8	44.6	45.4	46.2	47	47.8	48.6	49.4	50.2	51	51.8	52.6	53.4	54.2	55	55.8	56.6	57.4	58.2	59	59.8

Toll-Free Number : China 400-875-0009 Taiwan 0800-800-893

MEMO

Application

Standard/Ball Screw

Rod Type Actuator

Standard/Belt Type

Clean Room/Ball Screw

Clean Room/Belt Type

Linear Motor

Multi Axis

Alignment Stage

Reference

1 axis ETB

ETB5

ETB6

ETB10

ETB14M

ETB17M

ETB22M