

ECH10

1-axis

Ball Screw Drive



Maximum Stroke **1050mm**

Maximum Speed **1000mm/s**

Motor Output **100W**

Ball Screw ϕ 16mm

Linear Guide **ZDX18-1pc**

Ordering Method

ECH10-L5-100-M-M10B-C4-0001

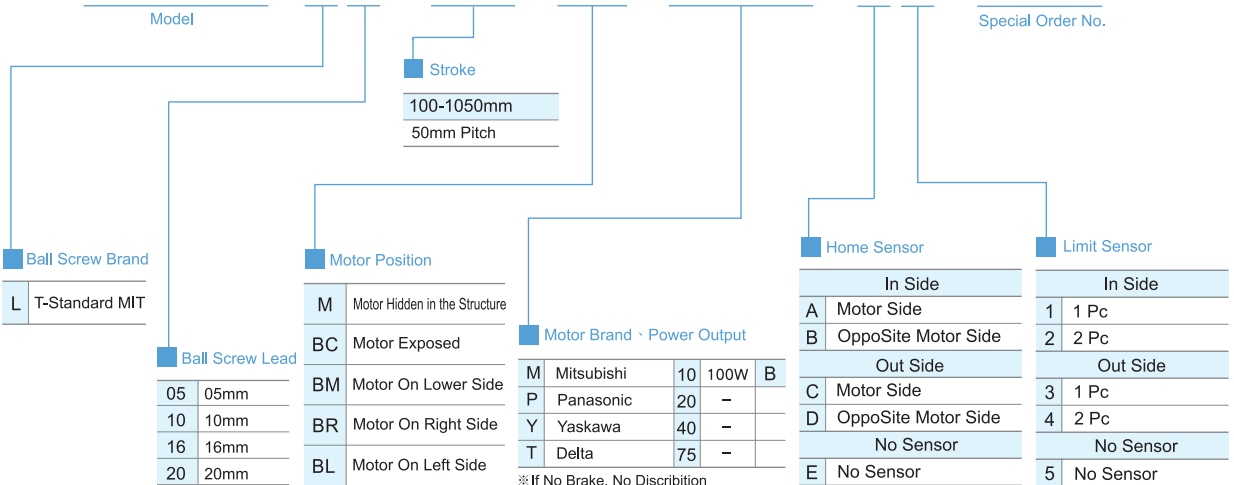

Application
Standard Ball Screw
Rod Type Actuator
Standard/Belt Type
Clean Room Ball Screw
Clean Room Belt Type
Linear Motor
Multi Axis
Alignment Stage
Reference

Specification

Function	Repeatability (mm)		±0.01			
	Belt Lead (mm)		5	10	16	20
	Maximum Speed (mm/s)		250	500	800	1000
	Maximum Payload	Horizontal (kg)	50	30	22	18
		Vertical (kg)	12	8	5	3
	Rated Thrust (N)		341	170	106	85
	Stroke Pitch (mm)		100-1050mm / 50mm Pitch			
Parts	AC Servo Motor Output (w)		100			
	Ball Screw Ø (mm)		C7 φ 16			
	High Rigidity Linear Guide (mm)		20 X 18			
	Coupling (mm)		8 X 10			
	Home Sensor	Outside	EE-SX672(NPN)			
Built In		EE-SX674(NPN)				

Sensor Layout

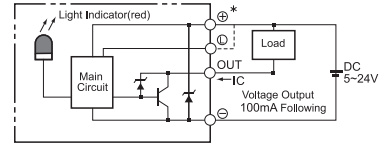

Allowable Overhang N.m

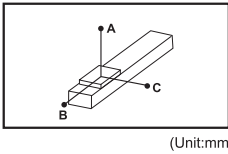

Horizontal Installation		A	B	C
Lead 5	30kg	424	24	25
	50kg	0	0	0
	-	-	-	-
Lead 10	15kg	394	76	79
	25kg	184	22	25
	30kg	111	-	-
Lead 16	5kg	937	282	259
	10kg	487	121	116
	22kg	236	40	44
Lead 20	5kg	940	285	264
	10kg	490	125	120
	15kg	240	45	48

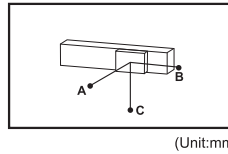

Wall Installation		A	B	C
Lead 5	10kg	105	50	1400
	20kg	22	0	538
	30kg	0	0	0
Lead 10	10kg	100	50	545
	20kg	20	0	221
	30kg	0	0	0
Lead 16	5kg	116	58	605
	10kg	24	0	253
	22kg	0	0	0
Lead 20	5kg	251	211	903
	10kg	97	49	436
	15kg	23	0	153

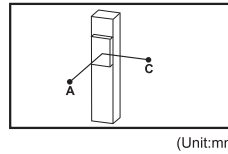

Vertical Installation		A	C
Lead 5	5kg	100	145
	10kg	50	90
	12kg	23	63
Lead 10	4kg	335	375
	6kg	140	180
	8kg	100	140
Lead 16	1kg	620	620
	2kg	680	680
	5kg	310	350
Lead 20	1kg	580	580
	2kg	645	645
	3kg	310	350

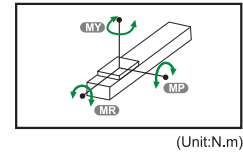

Static Loading Moment	
MY	110(N)
MP	110(N)
MR	120(N)

Suitable Motor Brand

Brand	Mark	Brake	Watp	AC-Voltage	Motor Model	Driver Model
Mitsubishi	M	No Brake (Horizontal Type)	100	220	HF-KP13	MR-J3-10A
		With Brake (Vertical Type)	100	220	HF-KP13B	MR-J3-10A
Panasonic	P	No Brake (Horizontal Type)	100	220	MSMD012P1S	MADDT1205
		With Brake (Vertical Type)	100	220	MSMD012P1T	MADDT1205
Delta	T	No Brake (Horizontal Type)	100	220	ECMA-C20401ES	ASD-B20121-B
		With Brake (Vertical Type)	100	220	ECMA-C20401FS	ASD-B20121-B

1 axis
ECH
ECH5M
ECH6M
ECH10
ECH12
ECH14
ECH17
ECH22

ECH10 1-axis

Motor Exposed /
Motor Hidden in the Structure

BC Motor Exposed



Welcome to download 2D/3D CAD and spec PDF

(mm)

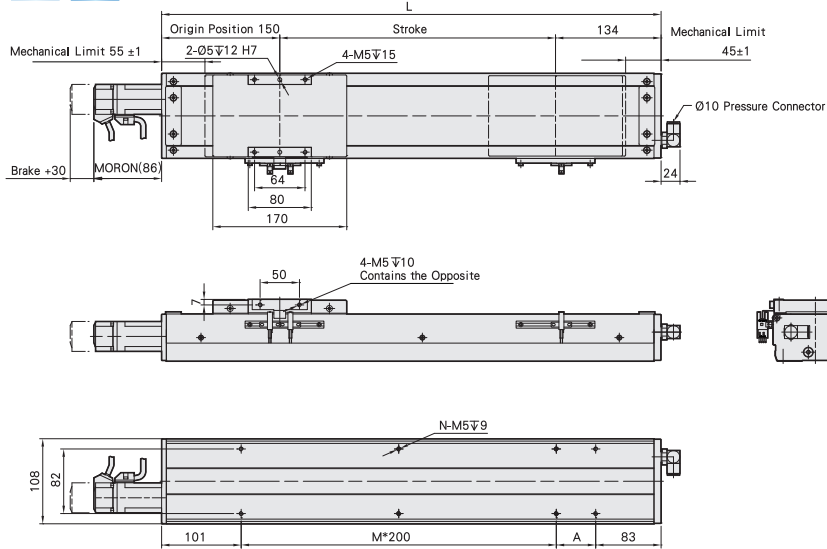

Stroke	100	150	200	250	300	350	400	450	500	550	600	650	700	750	800	850	900	950	1000	1050
L	394	434	484	534	584	634	684	734	784	834	884	934	984	1034	1084	1134	1184	1234	1284	1334
A	200	50	100	150	200	50	100	150	200	50	100	150	200	50	100	150	200	50	100	150
M	0	1	1	1	1	2	2	2	2	3	3	3	3	4	4	4	4	5	5	5
N	4	6	6	6	6	8	8	8	8	10	10	10	10	12	12	12	12	14	14	14
KG	8.5	8.8	9.2	9.6	10	10.4	10.8	11.2	11.5	11.9	12.3	12.7	13.1	13.5	13.9	14.2	14.6	15	15.4	15.8

M Motor Hidden in the Structure



Welcome to download 2D/3D CAD and spec PDF

(mm)

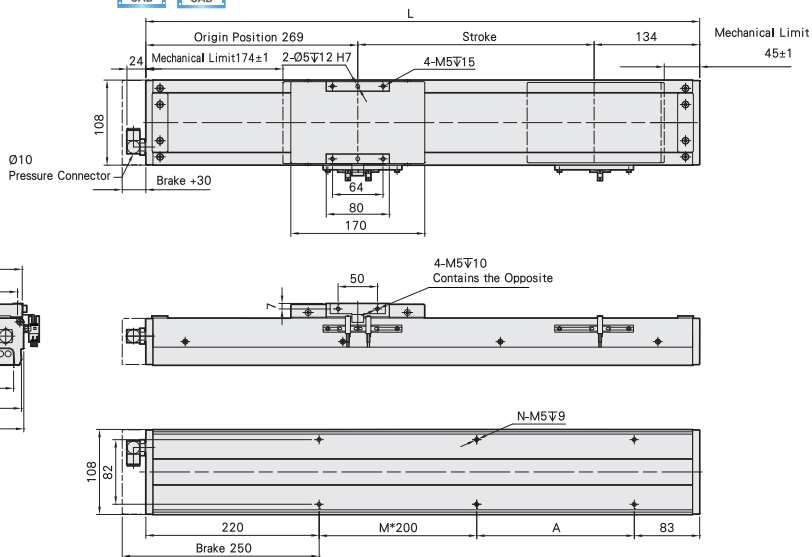

Stroke	100	150	200	250	300	350	400	450	500	550	600	650	700	750	800	850	900	950	1000	1050
L	503	553	603	653	703	753	803	853	903	953	1003	1053	1103	1153	1203	1253	1303	1353	1403	1453
A	200	50	100	150	200	50	100	150	200	50	100	150	200	50	100	150	200	50	100	150
M	0	1	1	1	1	2	2	2	2	3	3	3	3	4	4	4	4	5	5	5
N	4	6	6	6	6	8	8	8	8	10	10	10	10	12	12	12	12	14	14	14
KG	7	7.43	7.85	8.27	8.7	9.12	9.54	9.96	10.39	10.81	11.23	11.66	12.08	12.5	12.93	13.35	13.77	14.19	14.62	15.04

Motor On Left Side /
Motor On Right Side

Toll-Free Number : China 400-875-0009 Taiwan 0800-800-893

BL Motor On Left Side



Welcome to download 2D/3D CAD and spec PDF

(mm)

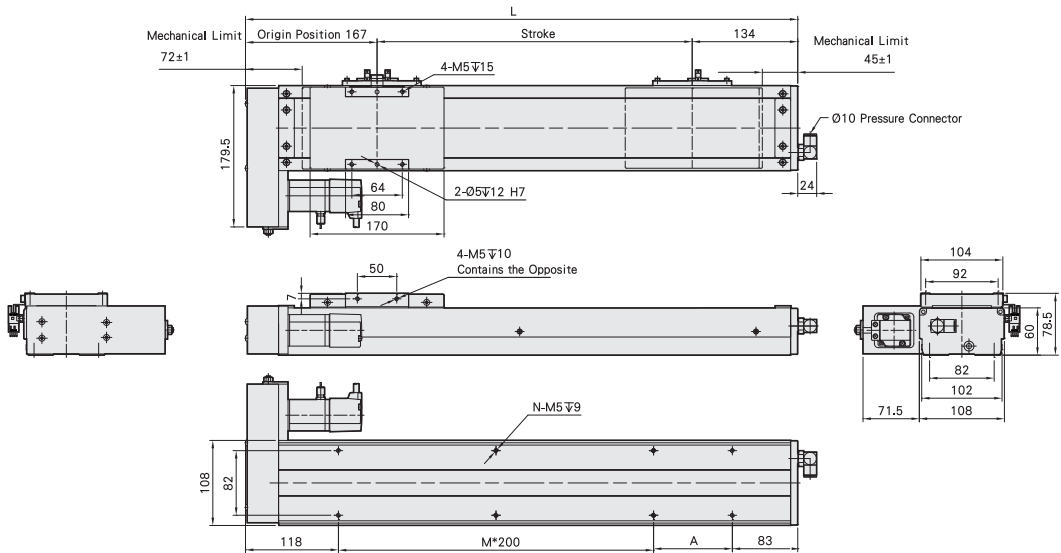

Stroke	100	150	200	250	300	350	400	450	500	550	600	650	700	750	800	850	900	950	1000	1050
L	401	451	501	551	601	651	701	751	801	851	901	951	1001	1051	1101	1151	1201	1251	1301	1351
A	200	50	100	150	200	50	100	150	200	50	100	150	200	50	100	150	200	50	100	150
M	0	1	1	1	1	2	2	2	2	3	3	3	3	4	4	4	4	5	5	5
N	4	6	6	6	6	8	8	8	8	10	10	10	10	12	12	12	12	14	14	14
KG	8.5	8.8	9.2	9.6	10	10.4	10.8	11.2	11.5	11.9	12.3	12.7	13.1	13.5	13.9	14.2	14.6	15	15.4	15.8

BR Motor On Right Side



Welcome to download 2D/3D CAD and spec PDF

(mm)

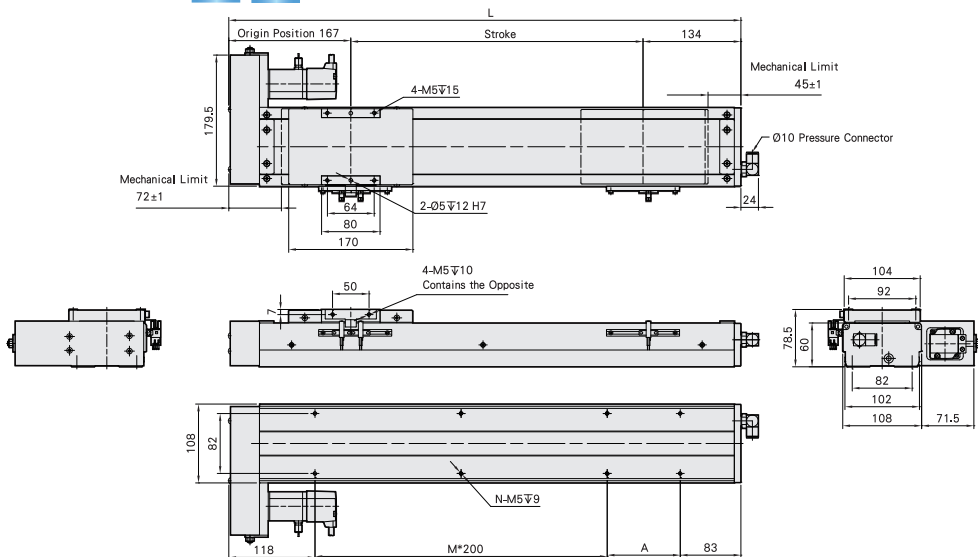

Stroke	100	150	200	250	300	350	400	450	500	550	600	650	700	750	800	850	900	950	1000	1050
L	401	451	501	551	601	651	701	751	801	851	901	951	1001	1051	1101	1151	1201	1251	1301	1351
A	200	50	100	150	200	50	100	150	200	50	100	150	200	50	100	150	200	50	100	150
M	0	1	1	1	1	2	2	2	2	3	3	3	3	4	4	4	4	5	5	5
N	4	6	6	6	6	8	8	8	8	10	10	10	10	12	12	12	12	14	14	14
KG	8.5	8.8	9.2	9.6	10	10.4	10.8	11.2	11.5	11.9	12.3	12.7	13.1	13.5	13.9	14.2	14.6	15	15.4	15.8

Application

Standard/Ball Screw

Foot Type Actuator

Standard/Ball Type

Clean Room/Ball Screw

Clean Room/Ball Type

Linear Motor

Multi Axis

Alignment Stage

Reference

1 axis ECH

ECH5M

ECH6M

ECH10

ECH12

ECH14

ECH17

ECH22

ECH10 1-axis

Motor On Lower Side

BM

Motor On Lower Side



Welcome to download 2D/3D CAD and spec PDF

(mm)

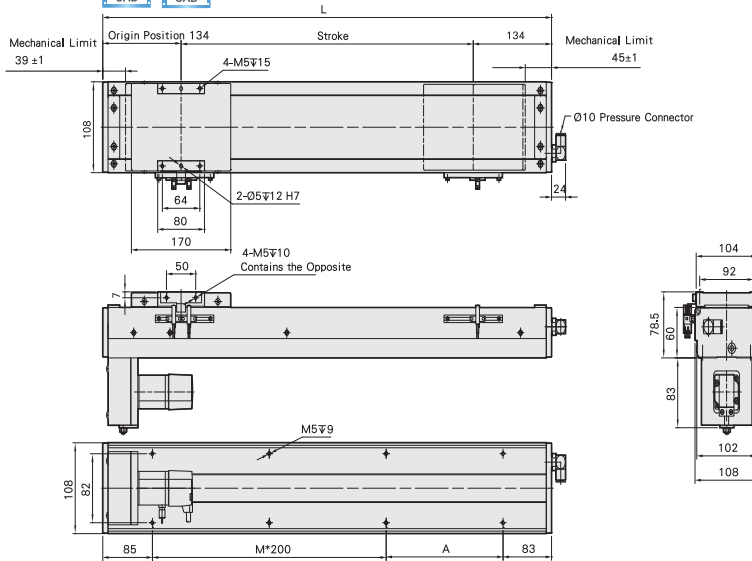

Stroke	100	150	200	250	300	350	400	450	500	550	600	650	700	750	800	850	900	950	1000	1050
L	368	418	468	518	568	618	668	718	768	818	868	918	968	1018	1068	1118	1168	1218	1268	1318
A	200	50	100	150	200	50	100	150	200	50	100	150	200	50	100	150	200	50	100	150
M	0	1	1	1	1	2	2	2	2	3	3	3	3	4	4	4	4	5	5	5
N	4	6	6	6	6	8	8	8	8	10	10	10	10	12	12	12	12	14	14	14
KG	8.5	8.8	9.2	9.6	10	10.4	10.8	11.2	11.5	11.9	12.3	12.7	13.1	13.5	13.9	14.2	14.6	15	15.4	15.8

Toll-Free Number : China 400-875-0009 Taiwan 0800-800-893

MEMO

Application

Standard/Ball Screw

Foot Type Actuator

Standard/Belt Type

Clean Room/Ball Screw

Clean Room/Belt Type

Linear Motor

Multi Axis

Alignment Stage

Reference

1 axis ECH

ECH5M

ECH6M

ECH10

ECH12

ECH14

ECH17

ECH22