

ECB10

1-axis

Belt Drive



Maximum Stroke	2550mm	Maximum Speed	1600mm/s	Motor Output	100W	Belt Width	15 mm	Linear Guide	ZOX18-1pc
----------------	--------	---------------	----------	--------------	------	------------	-------	--------------	-----------

Ordering Method

ECB10-L 32-100-L-M 10-C4-0001

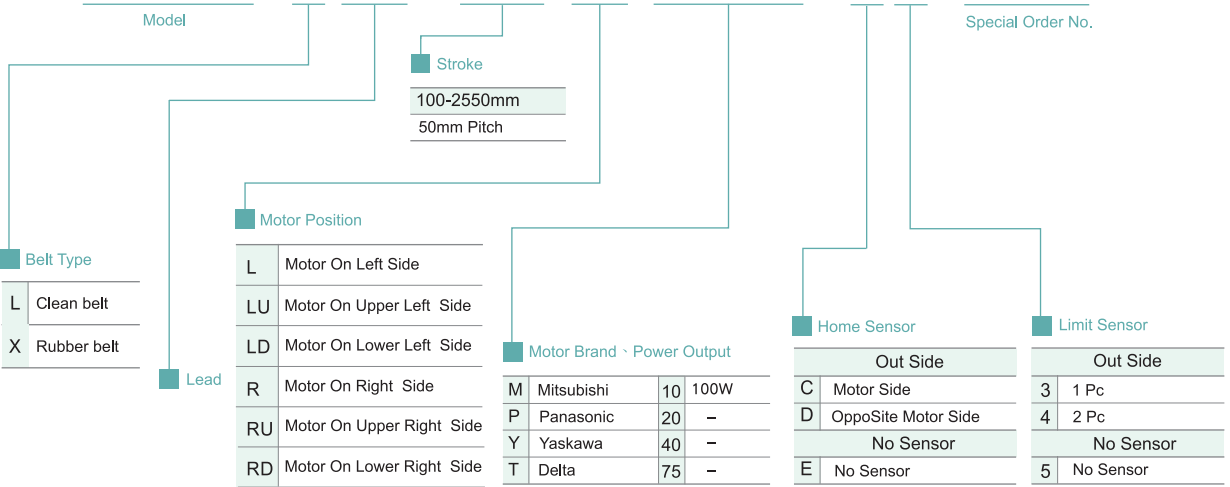

Specification

Function	Repeatability (mm)		±0.04
	Lead (mm)		32
	Maximum Speed (mm/s)		1600
	Maximum Payload	Horizontal (kg)	10
		Vertical (kg)	
	Rated Thrust (N)		61
Stroke Pitch (mm)		100-2550mm / 50mm Pitch	
Parts	AC Servo Motor Output (w)		100
	Belt Width		15
	High Rigidity Linear Guide (mm)		20X18
	Home Sensor	Outside	EE-SX672(NPN)

Sensor Layout

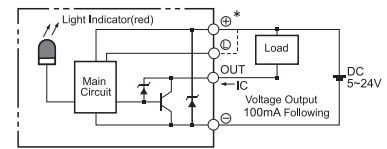

Allowable Overhang N.m

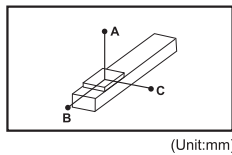

Horizontal Installation	A	B	C
5kg	1400	750	600
8kg	1100	450	400
10kg	1000	350	350

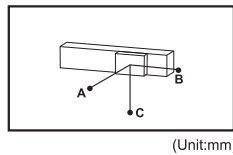

Wall Installation	A	B	C
5kg	660	500	1100
8kg	450	300	850
10kg	350	220	800

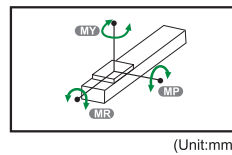

Static Loading Moment

MY	110(N)
MP	110(N)
MR	120(N)

Suitable Motor Brand

Brand	Mark	Brake	Watp	AC-Voltage	Motor Model	Driver Model
Mitsubishi	M	No Brake (Horizontal Type)	100	220	HF-KP13	MR-J3-10A
Panasonic	P	No Brake (Horizontal Type)	100	220	MSMD012P1S	MADDT1205
Delta	T	No Brake (Horizontal Type)	100	220	ECMA-C20401ES	ASD-B20121-B

Application
Standard/Belt Screw
Rod Type Actuator
Standard/Belt Type
Clean Room/Belt Screw
Clean Room/Belt Type
Linear Motor
Multi Axis
Alignment Stage
Reference

1 axis
ECB
ECB5
ECB6
ECB10
ECB14
ECB17
ECB22

ECB10

1-axis

Motor On Left Side /
Motor On Right Side

L Motor On Left Side



Welcome to download 2D/3D CAD and spec PDF

(mm)

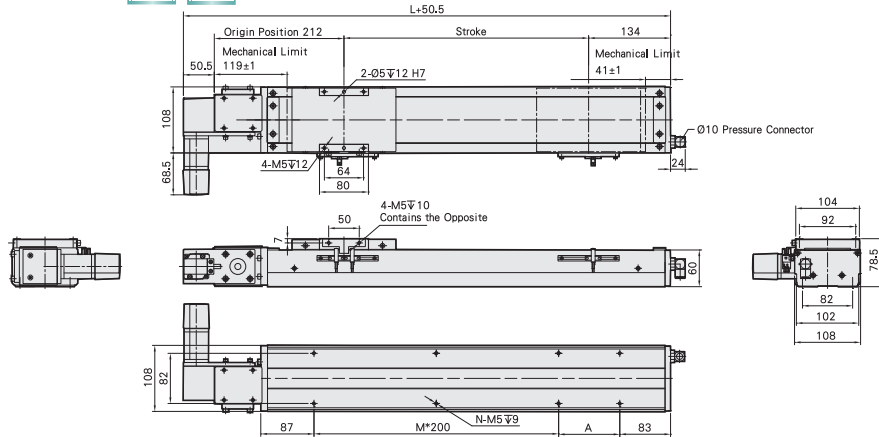

Stroke	100	150	200	250	300	350	400	450	500	550	600	650	700	750	800	850	900	950	1000	1050	1100	1150	1200	1250	1300
L	446	496	546	596	646	696	746	796	846	896	946	996	1046	1096	1146	1196	1246	1296	1346	1396	1446	1496	1546	1596	1646
A	200	50	100	150	200	50	100	150	200	50	100	150	200	50	100	150	200	50	100	150	200	50	100	150	200
M	0	1	1	1	1	2	2	2	2	3	3	3	4	4	4	4	5	5	5	5	5	6	6	6	6
N	4	6	6	6	6	8	8	8	8	8	10	10	10	12	12	12	12	14	14	14	14	16	16	16	16
KG	8.3	8.73	9.15	9.57	10	10.42	10.84	11.26	11.69	12.11	12.53	12.96	13.38	13.8	14.23	14.65	15.07	15.49	15.92	16.34	16.76	17.18	17.6	18.02	18.44

Stroke	1350	1400	1450	1500	1550	1600	1650	1700	1750	1800	1850	1900	1950	2000	2050	2100	2150	2200	2250	2300	2350	2400	2450	2500	2550
L	1696	1746	1796	1846	1896	1946	1996	2046	2096	2146	2196	2246	2296	2346	2396	2446	2496	2546	2596	2646	2696	2746	2796	2846	2896
A	50	100	150	200	50	100	150	200	50	100	150	200	50	100	150	200	50	100	150	200	50	100	150	200	50
M	7	7	7	7	8	8	8	8	9	9	9	10	10	10	10	11	11	11	11	11	12	12	12	12	13
N	18	18	18	18	20	20	20	20	22	22	22	22	24	24	24	24	26	26	26	26	28	28	28	28	30
KG	18.86	19.28	19.7	19.12	20.54	20.96	21.38	21.8	22.22	22.64	23.06	23.48	23.9	24.32	24.74	25.16	25.58	26	24.92	26.84	27.26	27.68	28.1	28.52	28.94

R Motor On Right Side



Welcome to download 2D/3D CAD and spec PDF

(mm)

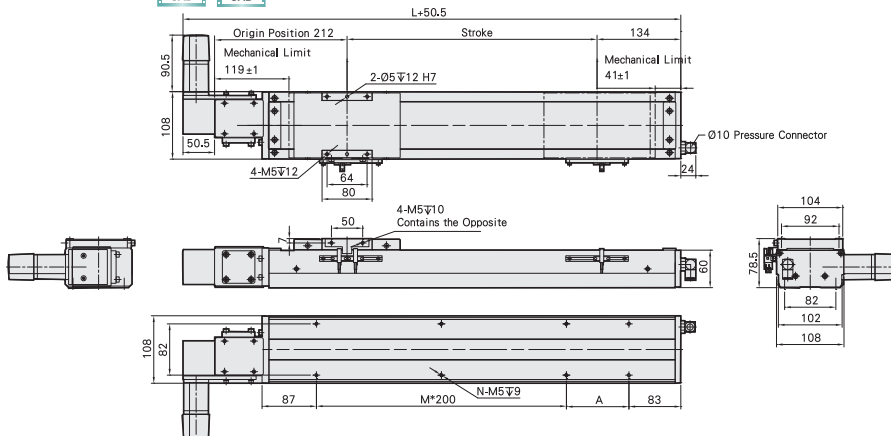

Stroke	100	150	200	250	300	350	400	450	500	550	600	650	700	750	800	850	900	950	1000	1050	1100	1150	1200	1250	1300
L	446	496	546	596	646	696	746	796	846	896	946	996	1046	1096	1146	1196	1246	1296	1346	1396	1446	1496	1546	1596	1646
A	200	50	100	150	200	50	100	150	200	50	100	150	200	50	100	150	200	50	100	150	200	50	100	150	200
M	0	1	1	1	1	2	2	2	2	3	3	3	4	4	4	4	5	5	5	5	5	6	6	6	6
N	4	6	6	6	6	8	8	8	8	10	10	10	10	12	12	12	12	14	14	14	14	16	16	16	16
KG	8.3	8.73	9.15	9.57	10	10.42	10.84	11.26	11.69	12.11	12.53	12.96	13.38	13.8	14.23	14.65	15.07	15.49	15.92	16.34	16.76	17.18	17.6	18.02	18.44

Stroke	1350	1400	1450	1500	1550	1600	1650	1700	1750	1800	1850	1900	1950	2000	2050	2100	2150	2200	2250	2300	2350	2400	2450	2500	2550
L	1696	1746	1796	1846	1896	1946	1996	2046	2096	2146	2196	2246	2296	2346	2396	2446	2496	2546	2596	2646	2696	2746	2796	2846	2896
A	50	100	150	200	50	100	150	200	50	100	150	200	50	100	150	200	50	100	150	200	50	100	150	200	50
M	7	7	7	7	8	8	8	8	9	9	9	10	10	10	10	11	11	11	11	11	12	12	12	12	13
N	18	18	18	18	20	20	20	20	22	22	22	22	24	24	24	24	26	26	26	26	28	28	28	28	30
KG	18.86	19.28	19.7	19.12	20.54	20.96	21.38	21.8	22.22	22.64	23.06	23.48	23.9	24.32	24.74	25.16	25.58	26	24.92	26.84	27.26	27.68	28.1	28.52	28.94

Motor On Lower Left Side /
Motor On Lower Right Side

Toll-Free Number : China 400-875-0009 Taiwan 0800-800-893

LD Motor On Lower Left Side



Welcome to download 2D/3D CAD and spec PDF

(mm)

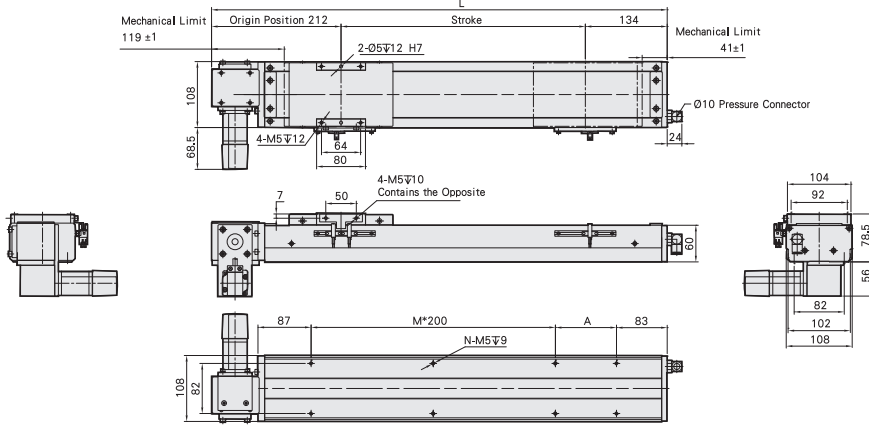

Stroke	100	150	200	250	300	350	400	450	500	550	600	650	700	750	800	850	900	950	1000	1050	1100	1150	1200	1250	1300
L	446	496	546	596	646	696	746	796	846	896	946	996	1046	1096	1146	1196	1246	1296	1346	1396	1446	1496	1546	1596	1646
A	200	50	100	150	200	50	100	150	200	50	100	150	200	50	100	150	200	50	100	150	200	50	100	150	200
M	0	1	1	1	1	2	2	2	2	3	3	3	3	4	4	4	4	5	5	5	5	6	6	6	6
N	4	6	6	6	6	8	8	8	8	10	10	10	10	12	12	12	12	14	14	14	14	16	16	16	16
KG	8.3	8.73	9.15	9.57	10	10.42	10.84	11.26	11.69	12.11	12.53	12.96	13.38	13.8	14.23	14.65	15.07	15.49	15.92	16.34	16.76	17.18	17.6	18.02	18.44

Stroke	1350	1400	1450	1500	1550	1600	1650	1700	1750	1800	1850	1900	1950	2000	2050	2100	2150	2200	2250	2300	2350	2400	2450	2500	2550
L	1696	1746	1796	1846	1896	1946	1996	2046	2096	2146	2196	2246	2296	2346	2396	2446	2496	2546	2596	2646	2696	2746	2796	2846	2896
A	50	100	150	200	50	100	150	200	50	100	150	200	50	100	150	200	50	100	150	200	50	100	150	200	50
M	7	7	7	7	8	8	8	8	9	9	9	9	10	10	10	10	11	11	11	11	12	12	12	12	13
N	18	18	18	18	20	20	20	20	22	22	22	22	24	24	24	24	26	26	26	26	28	28	28	28	30
KG	18.86	19.28	19.7	19.12	20.54	20.96	21.38	21.8	22.22	22.64	23.06	23.48	23.9	24.32	24.74	25.16	25.58	26	24.92	26.84	27.26	27.68	28.1	28.52	28.94

RD Motor On Lower Right Side



Welcome to download 2D/3D CAD and spec PDF

(mm)

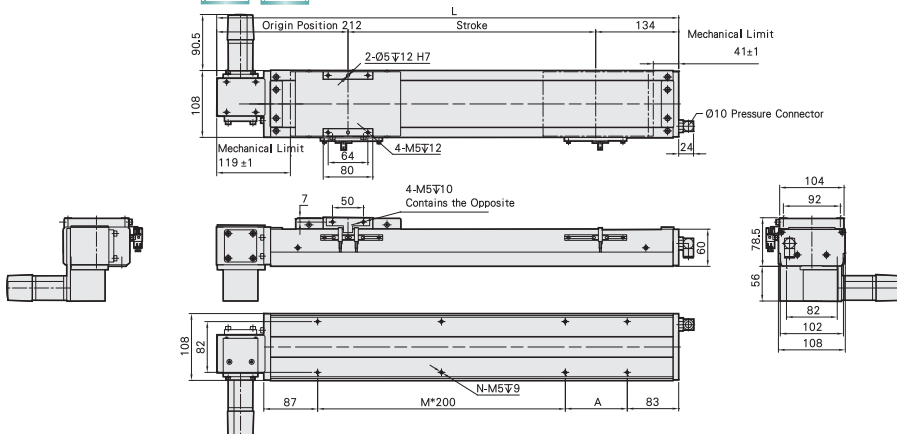

Stroke	100	150	200	250	300	350	400	450	500	550	600	650	700	750	800	850	900	950	1000	1050	1100	1150	1200	1250	1300
L	446	496	546	596	646	696	746	796	846	896	946	996	1046	1096	1146	1196	1246	1296	1346	1396	1446	1496	1546	1596	1646
A	200	50	100	150	200	50	100	150	200	50	100	150	200	50	100	150	200	50	100	150	200	50	100	150	200
M	0	1	1	1	1	2	2	2	2	3	3	3	3	4	4	4	4	5	5	5	5	6	6	6	6
N	4	6	6	6	6	8	8	8	8	10	10	10	10	12	12	12	12	14	14	14	14	16	16	16	16
KG	8.3	8.73	9.15	9.57	10	10.42	10.84	11.26	11.69	12.11	12.53	12.96	13.38	13.8	14.23	14.65	15.07	15.49	15.92	16.34	16.76	17.18	17.6	18.02	18.44

Stroke	1350	1400	1450	1500	1550	1600	1650	1700	1750	1800	1850	1900	1950	2000	2050	2100	2150	2200	2250	2300	2350	2400	2450	2500	2550
L	1696	1746	1796	1846	1896	1946	1996	2046	2096	2146	2196	2246	2296	2346	2396	2446	2496	2546	2596	2646	2696	2746	2796	2846	2896
A	50	100	150	200	50	100	150	200	50	100	150	200	50	100	150	200	50	100	150	200	50	100	150	200	50
M	7	7	7	7	8	8	8	8	9	9	9	9	10	10	10	10	11	11	11	11	12	12	12	12	13
N	18	18	18	18	20	20	20	20	22	22	22	22	24	24	24	24	26	26	26	26	28	28	28	28	30
KG	18.86	19.28	19.7	19.12	20.54	20.96	21.38	21.8	22.22	22.64	23.06	23.48	23.9	24.32	24.74	25.16	25.58	26	24.92	26.84	27.26	27.68	28.1	28.52	28.94

Application
Standard/Ball Screw
Rod Type Actuator
Standard/Ball Type
Clean Room/Ball Screw
Clean Room/Ball Type
Linear Motor
Multi Axis
Alignment Stage
Reference

1 axis
ECB
ECB5
ECB6
ECB10
ECB14
ECB17
ECB22

ECB10 1-axis

Motor On Upper Left Side /
Motor On Upper Right Side

LU Motor On Upper Left Side



Welcome to download 2D/3D CAD and spec PDF

(mm)

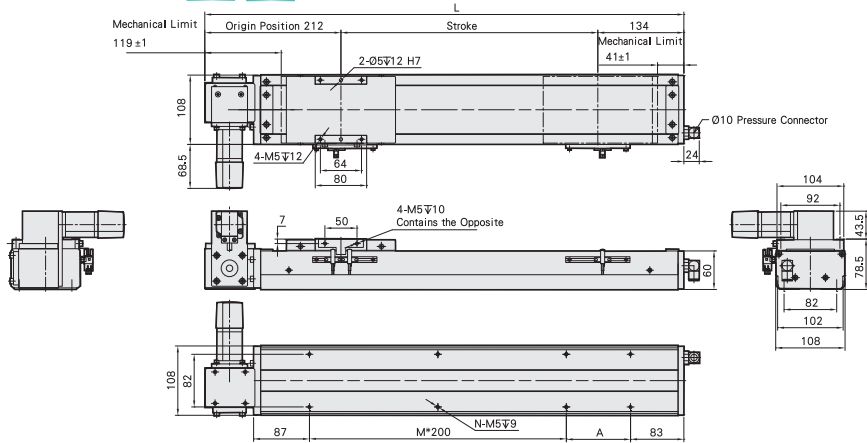

Stroke	100	150	200	250	300	350	400	450	500	550	600	650	700	750	800	850	900	950	1000	1050	1100	1150	1200	1250	1300
L	446	496	546	596	646	696	746	796	846	896	946	996	1046	1096	1146	1196	1246	1296	1346	1396	1446	1496	1546	1596	1646
A	200	50	100	150	200	50	100	150	200	50	100	150	200	50	100	150	200	50	100	150	200	50	100	150	200
M	0	1	1	1	1	2	2	2	2	3	3	3	4	4	4	4	5	5	5	5	5	6	6	6	6
N	4	6	6	6	6	8	8	8	8	10	10	10	12	12	12	12	14	14	14	14	14	16	16	16	16
KG	8.3	8.73	9.15	9.57	10	10.42	10.84	11.26	11.69	12.11	12.53	12.96	13.38	13.8	14.23	14.65	15.07	15.49	15.92	16.34	16.76	17.18	17.6	18.02	18.44

Stroke	1350	1400	1450	1500	1550	1600	1650	1700	1750	1800	1850	1900	1950	2000	2050	2100	2150	2200	2250	2300	2350	2400	2450	2500	2550
L	1696	1746	1796	1846	1896	1946	1996	2046	2096	2146	2196	2246	2296	2346	2396	2446	2496	2546	2596	2646	2696	2746	2796	2846	2896
A	50	100	150	200	50	100	150	200	50	100	150	200	50	100	150	200	50	100	150	200	50	100	150	200	50
M	7	7	7	7	8	8	8	8	9	9	9	9	10	10	10	10	11	11	11	11	11	12	12	12	13
N	18	18	18	18	20	20	20	20	22	22	22	22	24	24	24	24	26	26	26	26	26	28	28	28	30
KG	18.86	19.28	19.7	19.12	20.54	20.96	21.38	21.8	22.22	22.64	23.06	23.48	23.9	24.32	24.74	25.16	25.58	26	24.92	26.84	27.26	27.68	28.1	28.52	28.94

RU Motor On Upper Right Side



Welcome to download 2D/3D CAD and spec PDF

(mm)

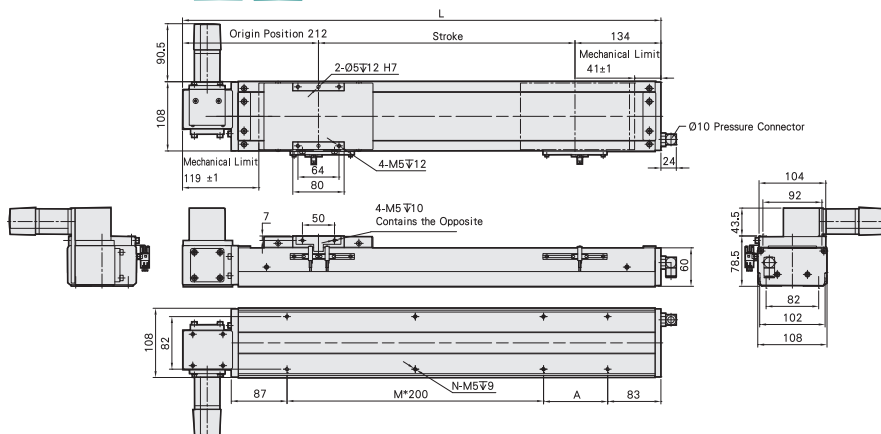

Stroke	100	150	200	250	300	350	400	450	500	550	600	650	700	750	800	850	900	950	1000	1050	1100	1150	1200	1250	1300
L	446	496	546	596	646	696	746	796	846	896	946	996	1046	1096	1146	1196	1246	1296	1346	1396	1446	1496	1546	1596	1646
A	200	50	100	150	200	50	100	150	200	50	100	150	200	50	100	150	200	50	100	150	200	50	100	150	200
M	0	1	1	1	1	2	2	2	2	3	3	3	4	4	4	4	5	5	5	5	5	6	6	6	6
N	4	6	6	6	6	8	8	8	8	10	10	10	12	12	12	12	14	14	14	14	14	16	16	16	16
KG	8.3	8.73	9.15	9.57	10	10.42	10.84	11.26	11.69	12.11	12.53	12.96	13.38	13.8	14.23	14.65	15.07	15.49	15.92	16.34	16.76	17.18	17.6	18.02	18.44

Stroke	1350	1400	1450	1500	1550	1600	1650	1700	1750	1800	1850	1900	1950	2000	2050	2100	2150	2200	2250	2300	2350	2400	2450	2500	2550
L	1696	1746	1796	1846	1896	1946	1996	2046	2096	2146	2196	2246	2296	2346	2396	2446	2496	2546	2596	2646	2696	2746	2796	2846	2896
A	50	100	150	200	50	100	150	200	50	100	150	200	50	100	150	200	50	100	150	200	50	100	150	200	50
M	7	7	7	7	8	8	8	8	9	9	9	9	10	10	10	10	11	11	11	11	11	12	12	12	13
N	18	18	18	18	20	20	20	20	22	22	22	22	24	24	24	24	26	26	26	26	26	28	28	28	30
KG	18.86	19.28	19.7	19.12	20.54	20.96	21.38	21.8	22.22	22.64	23.06	23.48	23.9	24.32	24.74	25.16	25.58	26	24.92	26.84	27.26	27.68	28.1	28.52	28.94

Toll-Free Number : China 400-875-0009 Taiwan 0800-800-893

MEMO

Application

Standard/Ball Screw

Rod Type Actuator

Standard/Belt Type

Clean Room/Ball Screw

Clean Room/Belt Type

Linear Motor

Multi Axis

Alignment Stage

Reference

1 axis ECB

ECB5

ECB6

ECB10

ECB14

ECB17

ECB22