

## 12.3 Full Roller Type, MSR Series

### A. Construction

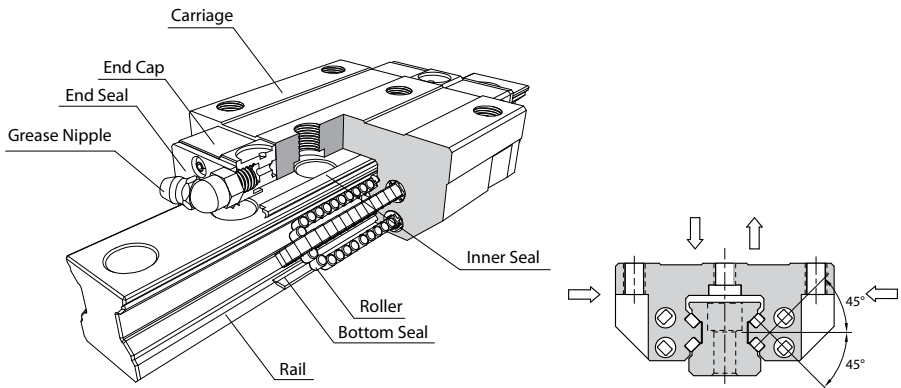

### B. Characteristics

The full roller type linear guideway, MSR series, equip with rollers instead of the ball, and therefore the MSR series can provide higher rigidity and loading than the normal type with the same size. Especially suit for the requests of high accuracy, heavy load and high rigidity.

#### Ultra Heavy Load

MSR linear guideway through rollers have a line contact with carriage and rail. Relative to the general type linear guideway through balls have a point contact; the MSR type linear guideway can offer lower elastic deformation while bearing the same load. Base on the rollers have the same outer diameter with balls, the roller can bear the heavier load. The excellent characteristics of high rigidity and ultra heavy load can suitable for the high accuracy application that heavy load is processed even more.

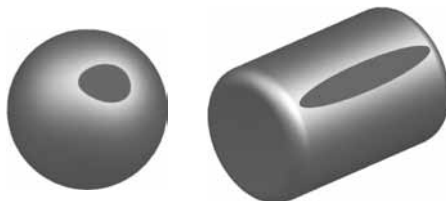

### The Optimization Design of Four Directional Load

Through the structure stress analysis of finite element method, SMR series have four trains of rollers are designed to a contact angle of 45° and the section design for high rigidity. Except for bearing heavier loads in radial, reversed radial and lateral directions, a sufficient preload can be achieved to increase rigidity, and this makes it suitable for any kind of installation.

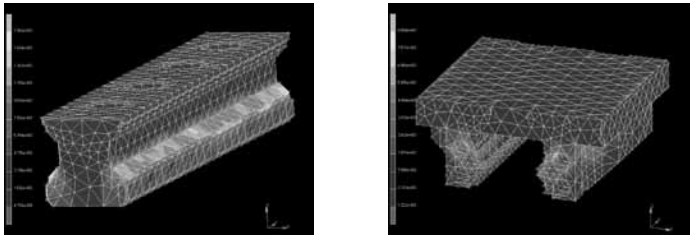

### Ultra High Rigidity

Test data of rigidity

- Test samples : Ball type MSA30LE with preload F1
- Full roller type MSR30LE with preload F1
- Roller chain type SMR30LE with preload F1

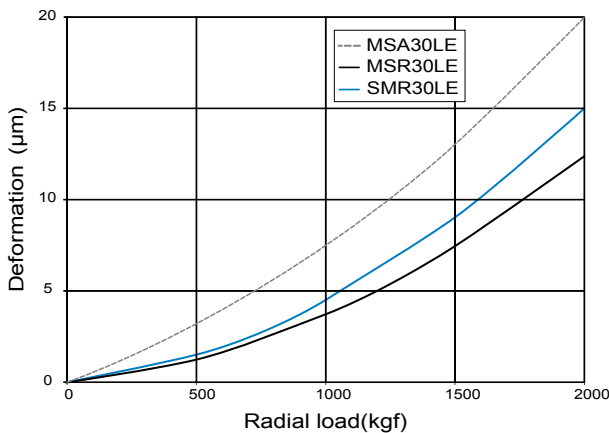
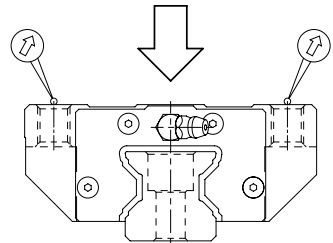

## C. Carriage Type

### Heavy Load

#### MSR-E Type

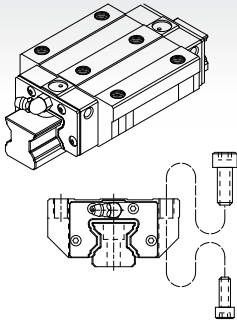

This type offers the installation either from top or bottom side of carriage.

#### MSR-S Type

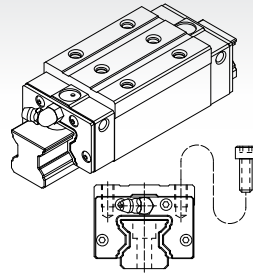

Square type with smaller width and can be installed from top side of carriage.

### Ultra Heavy Load

#### MSR-LE Type

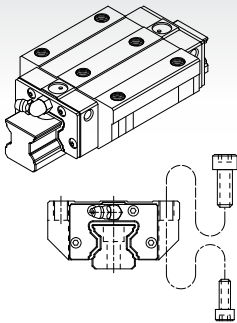

All dimensions are same as MSR-E except the length is longer, which makes it more rigid.

#### MSR-LS Type

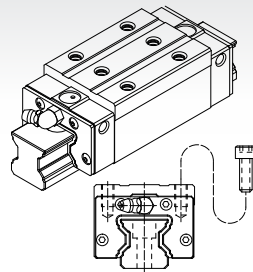

All dimensions are same as MSR-S except the length is longer, which makes it more rigid.

## D. Rail Type

Counter bore (R type)

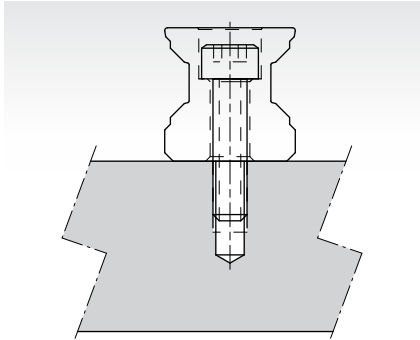

Tapped Hole (T type)

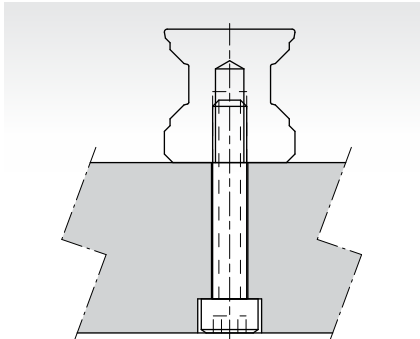

## E. Description of Specification

### (1) Non-interchangeable Type

	MSR	25	E	2	SS	F0
Series : MSR						
Size : 25, 30, 35, 45, 55, 65						
Carriage type : (1) Heavy load E : Flange type, mounting either from top or bottom S : Square type (2) Ultra heavy load LE : Flange type, mounting either from top or bottom LS : Square type						
Number of carriages per rail : 1, 2, 3 ...						
Dust protection option of carriage : No symbol, UU, SS, ZZ, DD, KK (refer to chapter 15.1 Dust Proof)						
Preload : F0 (Medium preload), F1 (Heavy preload), F2 (Ultra Heavy Preload)						
Code of special carriage : No symbol, A, B, C, D ...						
Rail type : R (Counter bore type), T (Tapped hole type)						
Rail length (mm)						
Rail hole pitch from start side (E1 see Fig12.3)						
Rail hole pitch to the end side (E2 see Fig12.3)						
Accuracy grade : H, P, SP, UP						
Code of special rail : No symbol, A, B ...						
Dust protection option of rail : No symbol, /CC, /MC, /MD ... (refer to chapter 15.1 Code of contamination fro Rail)						
Number of rails per axis : No symbol, II, III, IV ...						

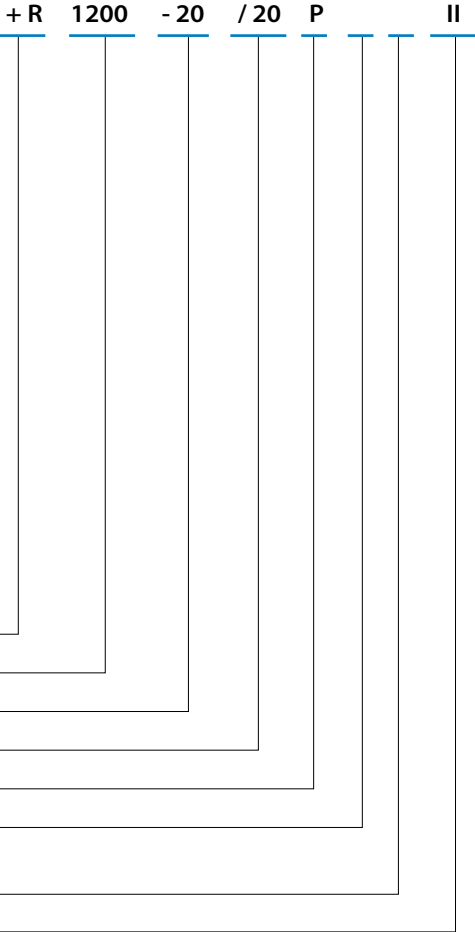
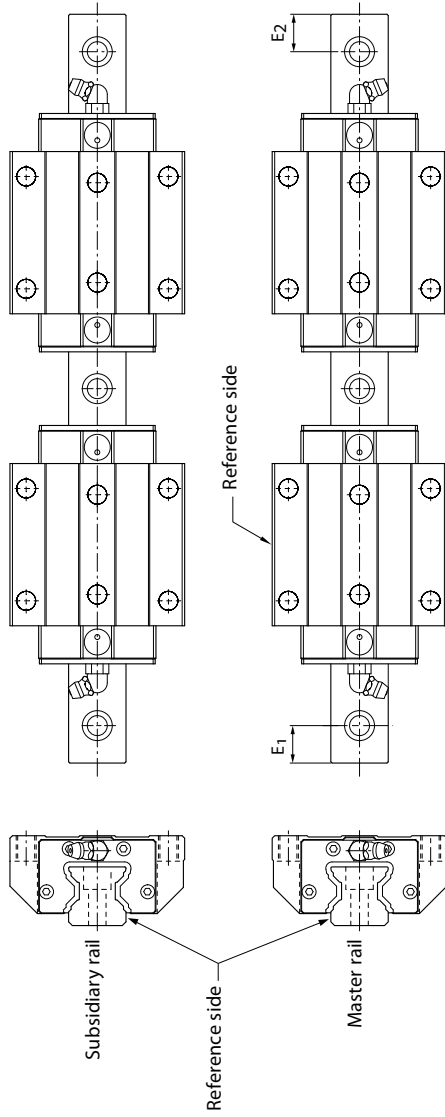
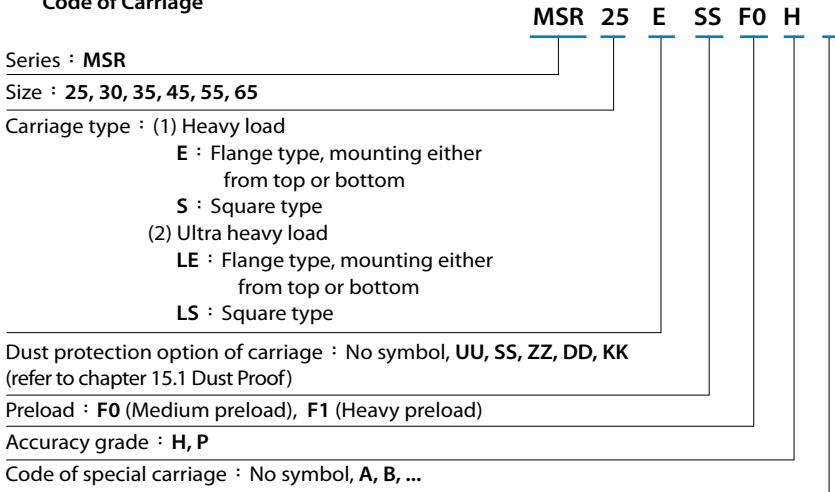

Fig. 12.3



## (2) Interchangeable Type

### Code of Carriage



### Code of Rail

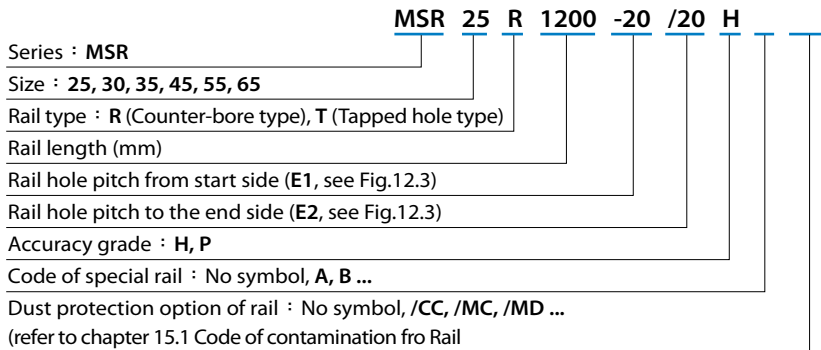



## F. Accuracy Grade

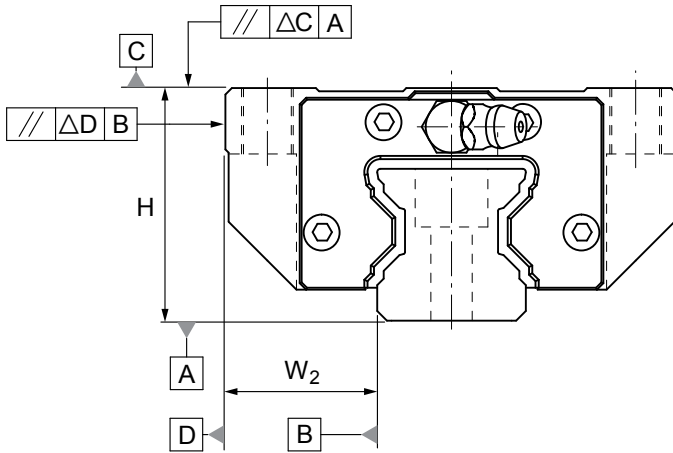

**Table 1 Running Parallelism**

Rail length (mm)		Running Parallelism Values ( $\mu\text{m}$ )			
Above	Or less	H	P	SP	UP
0	315	6	3	2	1.5
315	400	8	4	2	1.5
400	500	9	5	2	1.5
500	630	11	6	2.5	1.5
630	800	12	7	3	2
800	1000	14	8	4	2
1000	1250	16	10	5	2.5
1250	1600	18	11	6	3
1600	2000	20	13	7	3.5
2000	2500	22	15	8	4
2500	3000	24	16	9	4.5
3000	3500	25	17	11	5
3500	4000	26	18	12	6

### A Non-Interchangeable Type

Model No.	Item.	Accuracy Grade			
		High H	Precision P	Super Precision SP	Ultra Precision UP
25 30 35	Tolerance for height H	±0.04	0 -0.04	0 -0.02	0 -0.01
	Height difference ΔH	0.015	0.007	0.005	0.003
	Tolerance for distance W <sub>2</sub>	±0.04	0 -0.04	0 -0.02	0 -0.01
	Difference in distance W <sub>2</sub> (ΔW <sub>2</sub> )	0.015	0.007	0.005	0.003
	Running parallelism of surface C with surface A	ΔC (see the table 1)			
	Running parallelism of surface D with surface B	ΔD (see the table 1)			
45 55	Tolerance for height H	±0.05	0 -0.05	0 -0.03	0 -0.02
	Height difference ΔH	0.015	0.007	0.005	0.003
	Tolerance for distance W <sub>2</sub>	±0.05	0 -0.05	0 -0.03	0 -0.02
	Difference in distance W <sub>2</sub> (ΔW <sub>2</sub> )	0.02	0.01	0.007	0.005
	Running parallelism of surface C with surface A	ΔC (see the table 1)			
	Running parallelism of surface D with surface B	ΔD (see the table 1)			
65	Tolerance for height H	±0.07	0 -0.07	0 -0.05	0 -0.03
	Height difference ΔH	0.02	0.01	0.007	0.005
	Tolerance for distance W <sub>2</sub>	±0.07	0 -0.07	0 -0.05	0 -0.03
	Difference in distance W <sub>2</sub> (ΔW <sub>2</sub> )	0.025	0.015	0.01	0.007
	Running parallelism of surface C with surface A	ΔC (see the table 1)			
	Running parallelism of surface D with surface B	ΔD (see the table 1)			

## B Interchangeable Type

Model No.	Item.	Accuracy Grade	
		High H	Precision P
25 30 35	Tolerance for height H	±0.04	0 -0.04
	Height difference $\Delta H$	0.015	0.007
	Tolerance for distance $W_2$	±0.04	0 -0.04
	Difference in distance $W_2(\Delta W_2)$	0.015	0.007
	Running parallelism of surface C with surface A	$\Delta C$ (see the table 1)	
	Running parallelism of surface D with surface B	$\Delta D$ (see the table 1)	
45 55	Tolerance for height H	±0.05	0 -0.05
	Height difference $\Delta H$	0.015	0.007
	Tolerance for distance $W_2$	±0.05	0 -0.05
	Difference in distance $W_2(\Delta W_2)$	0.02	0.01
	Running parallelism of surface C with surface A	$\Delta C$ (see the table 1)	
	Running parallelism of surface D with surface B	$\Delta D$ (see the table 1)	
65	Tolerance for height H	±0.07	0 -0.07
	Height difference $\Delta H$	0.02	0.01
	Tolerance for distance $W_2$	±0.07	0 -0.07
	Difference in distance $W_2(\Delta W_2)$	0.025	0.015
	Running parallelism of surface C with surface A	$\Delta C$ (see the table 1)	
	Running parallelism of surface D with surface B	$\Delta D$ (see the table 1)	

## G. Preload Grade

Series	Preload grade		
	Medium preload (F0)	Heavy preload(F1)	Ultra heavy preload(F2)
MSR25	0.04~0.06C	0.07~0.09C	0.12~0.14C
MSR30			
MSR35			
MSR45			
MSR55			
MSR25L	0.04~0.06C	0.07~0.09C	0.12~0.14C
MSR30L			
MSR35L			
MSR45L			
MSR55L			
MSR65L			

Note: C is basic dynamic load rating in above table. Refer to the specification of products, please.

## H. The Shoulder Height and Corner Radius for Installation

### MSR series

Unit: mm

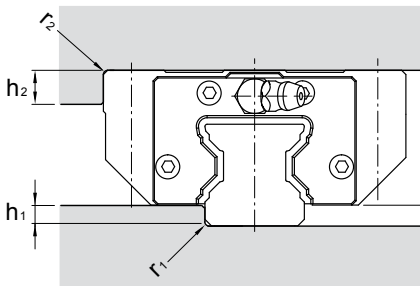

Model No.	$r_1$ (max.)	$r_2$ (max.)	$h_1$	$h_2$	$H_2$
25	0.5	0.5	4	8	4.8
30	0.5	0.5	5	8	6
35	1	1	5.5	10	6.5
45	1	1	6	12	8.1
55	1	1	8	15	10
65	1	1	10	15	12

## I. Dimensional Tolerance of Mounting Surface

### MSR Series

With the high rigidity, the minor dimensional error in mounting surface could be compensated and achieves smooth linear motion. The tolerances of parallelism between two axes are shown as below.

### The parallel deviation between two axes ( $e_1$ )

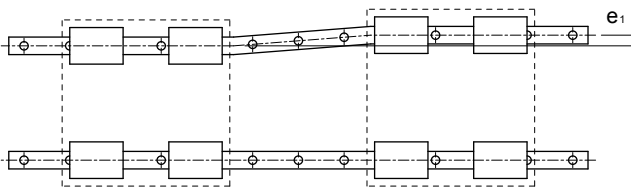

Unit:  $\mu m$

Model No.	Preload Grade		
	F0	F1	F2
25	9	7	5
30	11	8	6
35	14	10	7
45	17	13	9
55	21	14	11
65	27	18	14

Level difference between two axes ( $e_2$ )

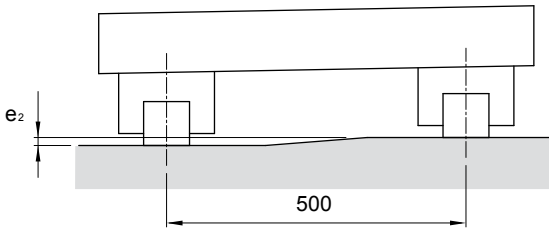

Unit:  $\mu\text{m}$

Model No.	Preload Grade		
	F0	F1	F2
25	150	105	55
30			
35			
45			
55			
65			

Note: The permissible values in table are applicable when the span is 500mm wide.

## J. Rail Maximum Length and Standrad

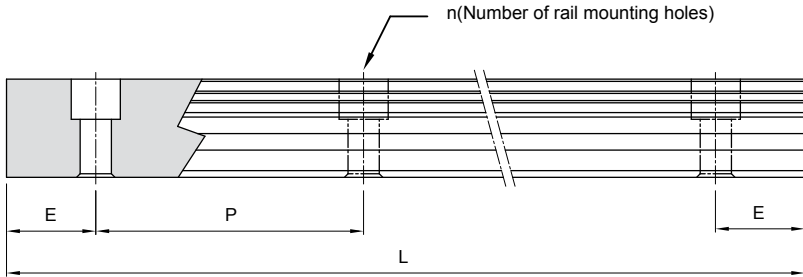

$$L = (n-1) \times P + 2 \times E$$

$L$ : Total Length of rail ( $mm$ )

$n$ : Nuber of mounting holes

$P$ : Distance between any two holes ( $mm$ )

$E$ : Distance from the center of the last hole to the edge ( $mm$ )

Unit: mm

Model No.	Standard Pitch (P)	Standard ( $E_{std.}$ )	Minimum ( $E_{min.}$ )	Max ( $L_0$ max.)
MSR 25	30	20	7	4000
MSR 30	40	20	8	4000
MSR 35	40	20	8	4000
MSR 45	52.5	22.5	11	4000
MSR 55	60	30	13	4000
MSR 65	75	35	14	4000

## K. Tapped-hole Rail Dimensions

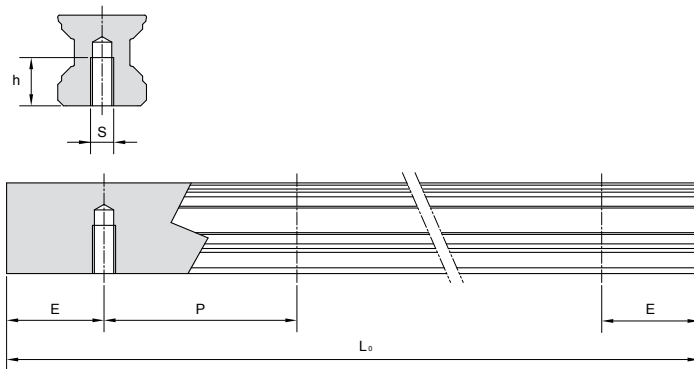

Rail Model	S	h(mm)
MSR 25 T	M6	12
MSR 30 T	M8	15
MSR 35 T	M8	17
MSR 45 T	M12	24
MSR 55 T	M14	24
MSR 65 T	M20	30



# Dimensions of MSR-E / MSR-LE

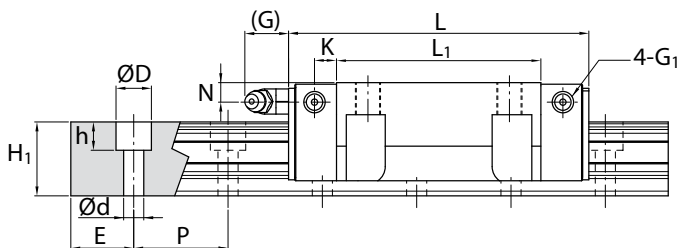
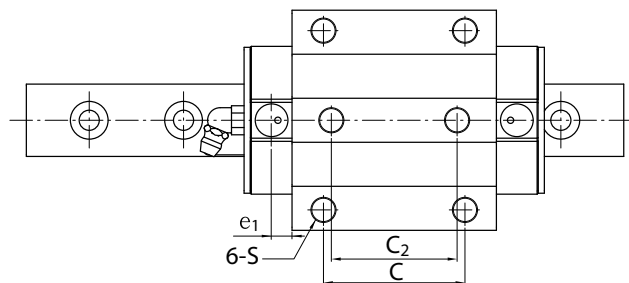

Unit: mm

Model No.	External dimension				Carriage dimension														Grease Nipple	
	Height H	Width W	Length L	W <sub>2</sub>	H <sub>2</sub>	B	C	C <sub>2</sub>	S	L <sub>1</sub>	T	T <sub>1</sub>	T <sub>2</sub>	T <sub>3</sub>	N	G	K	e <sub>1</sub>		G <sub>1</sub>
MSR 25 E MSR 25 LE	36	70	97.5 115.5	23.5	4.8	57	45	40	M8	65.5 83.5	9.5	20.2	10	5.8	6	12	6.6	6.5	M6	G-M6
MSR 30 E MSR 30 LE	42	90	112.4 135.2	31	6	72	52	44	M10	75.9 98.7	10	21.6	13	6.7	7	12	8	7	M6	G-M6
MSR 35 E MSR 35 LE	48	100	125.3 153.5	33	6.5	82	62	52	M10	82.3 110.5	12	27.5	15	9.5	8	12	8	7	M6	G-M6
MSR 45 E MSR 45 LE	60	120	154.2 189.4	37.5	8	100	80	60	M12	106.5 141.7	14.5	35.5	15	12.5	10	13.5	10	10	M6	G-PT 1/8
MSR 55 E MSR 55 LE	70	140	185.4 235.4	43.5	10	116	95	70	M14	129.5 179.5	17.5	41	18	15.5	11	13.5	12	7.95	M6	G-PT 1/8
MSR 65 LE	90	170	302	53.5	12	142	110	82	M16	230	19.5	56	20	26	16.5	13.5	15	15	M6	G-PT 1/8

Note\*: Single: Single carriage/ Double: Double carriages closely contacting with each other.

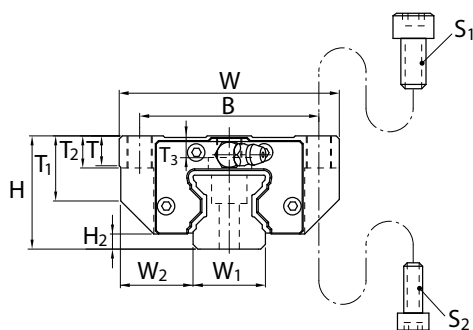
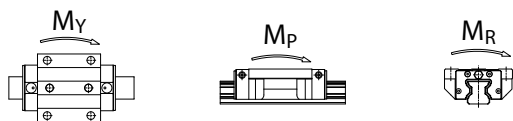

Model No.	Bolt Size	
	S <sub>1</sub>	S <sub>2</sub>
MSR 25	M8	M6
MSR 30	M10	M8
MSR 35	M10	M8
MSR 45	M12	M10
MSR 55	M14	M12
MSR 65	M16	M14

Unit: mm

Model No.	Rail dimension					Basic load rating		Static moment rating					Weight	
	Width W <sub>1</sub>	Height H <sub>1</sub>	Pitch P	E std.	D × h × d	Dynamic C kN	Static C <sub>0</sub> kN	M <sub>p</sub> kN-m		M <sub>v</sub> kN-m		M <sub>R</sub> kN-m	Carriage kg	Rail kg/m
								Single*	Double*	Single*	Double*			
MSR 25 E MSR 25 LE	23	23.5	30	20	11×9×7	29.6 36.3	63.8 82.9	0.65 1.08	3.82 5.94	0.65 1.08	3.82 5.94	0.73 0.95	0.75 0.95	3.5
MSR 30 E MSR 30 LE	28	27.5	40	20	14×12×9	42.8 54.0	91.9 124.0	1.09 1.96	6.38 10.60	1.09 1.96	6.38 10.60	1.27 1.75	1.4 1.72	5
MSR 35 E MSR 35 LE	34	30.5	40	20	14×12×9	57.9 73.9	123.5 169.0	1.59 2.94	9.56 16.18	1.59 2.94	9.56 16.18	2.09 2.85	1.95 2.45	7
MSR 45 E MSR 45 LE	45	37	52.5	22.5	20×17×14	92.8 117.2	193.8 261.6	3.28 5.90	18.76 31.32	3.28 5.90	18.76 31.32	4.40 5.94	3.9 4.5	11.2
MSR 55 E MSR 55 LE	53	43	60	30	23×20×16	132.8 172.5	270.0 378.0	5.49 10.60	31.18 55.58	5.49 10.60	31.18 55.58	7.33 10.28	6 7.9	15.6
MSR 65 LE	63	52	75	35	26×22×18	277.0	624.0	22.50	117.87	22.50	117.87	20.02	17.6	22.4

# Dimensions of MSR-S / MSR-LS

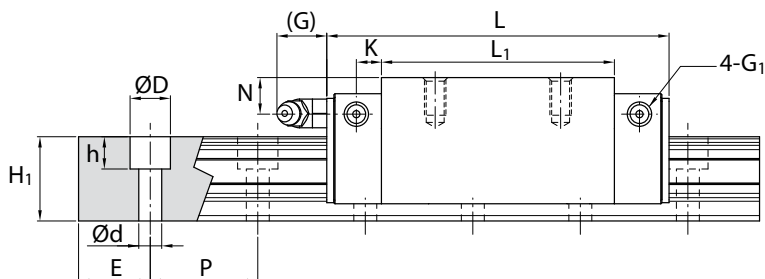
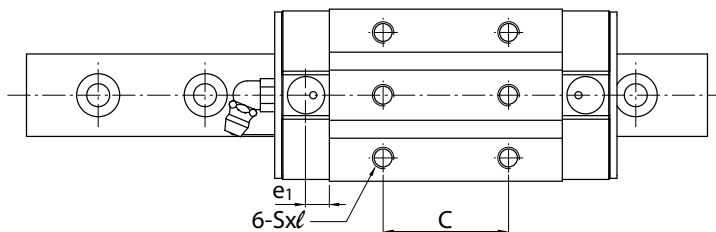

Unit: mm

Model No.	External dimension					Carriage dimension												
	Height H	Width W	Length L	W <sub>2</sub>	H <sub>2</sub>	B	C	S	ℓ	L <sub>1</sub>	T	N	G	K	e <sub>1</sub>	G <sub>1</sub>	Grease Nipple	
MSR 25 S	40	48	97.5	12.5	4.8	35	35	M6	9	65.5	9.5	10	12	6.6	6.5	M6	G-M6	
MSR 25 LS			115.5							83.5								
MSR 30 S	45	60	112.4	16	6	40	40	M8	12	75.9	10	10	12	8	7	M6	G-M6	
MSR 30 LS			135.2							98.7								
MSR 35 S	55	70	125.3	18	6.5	50	50	M8	14	82.3	12	15	12	8	7	M6	G-M6	
MSR 35 LS			153.5							110.5								
MSR 45 S	70	86	154.2	20.5	8	60	60	M10	19	106.5	17	20	13.5	10	10	M6	G-PT 1/8	
MSR 45 LS			189.4							141.7								
MSR 55 S	80	100	185.4	23.5	10	75	75	M12	19	129.5	18	21	13.5	12	7.95	M6	G-PT 1/8	
MSR 55 LS			235.4							179.5								
MSR 65 LS	90	126	302	31.5	12	76	120	M16	20	230	19.5	16.5	13.5	15	15	M6	G-PT 1/8	

Note\*: Single: Single carriage/ Double: Double carriages closely contacting with each other.

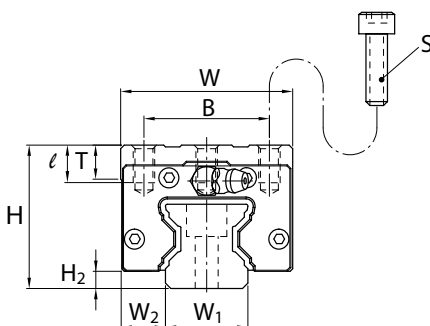
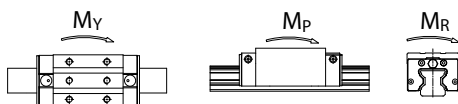

Unit: mm

Model No.	Rail dimension					Basic load rating		Static moment rating				Weight		
	Width $W_1$	Height $H_1$	Pitch $P$	E std.	D × h × d	Dynamic C kN	Static $C_o$ kN	$M_p$		$M_y$		$M_r$ kN-m	Carriage kg	Rail kg/m
								Single*	Double*	Single*	Double*			
MSR 25 S MSR 25 LS	23	23.5	30	20	11×9×7	29.6 36.3	63.8 82.9	0.65 1.08	3.82 5.94	0.65 1.08	3.82 5.94	0.73 0.95	0.65 0.85	3.5
MSR 30 S MSR 30 LS	28	27.5	40	20	14×12×9	42.8 54.0	91.9 124.0	1.09 1.96	6.38 10.60	1.09 1.96	6.38 10.60	1.27 1.72	1 1.22	5
MSR 35 S MSR 35 LS	34	30.5	40	20	14×12×9	57.9 73.9	123.5 169.0	1.59 2.94	9.56 16.18	1.59 2.94	9.56 16.18	2.09 2.85	1.65 2.15	7
MSR 45 S MSR 45 LS	45	37	52.5	22.5	20×17×14	92.8 117.2	193.8 261.6	3.28 5.90	18.76 31.32	3.28 5.90	18.76 31.32	4.40 5.94	3.2 4.1	11.2
MSR 55 S MSR 55 LS	53	43	60	30	23×20×16	132.8 172.5	270.0 378.0	5.49 10.60	31.18 55.58	5.49 10.60	31.18 55.58	7.33 10.26	5.1 7	15.6
MSR 65 LS	63	52	75	35	26×22×18	277.0	624.0	22.50	117.87	22.50	117.87	20.02	13.3	22.4