

# ETH22

1-axis

Ball Screw Drive

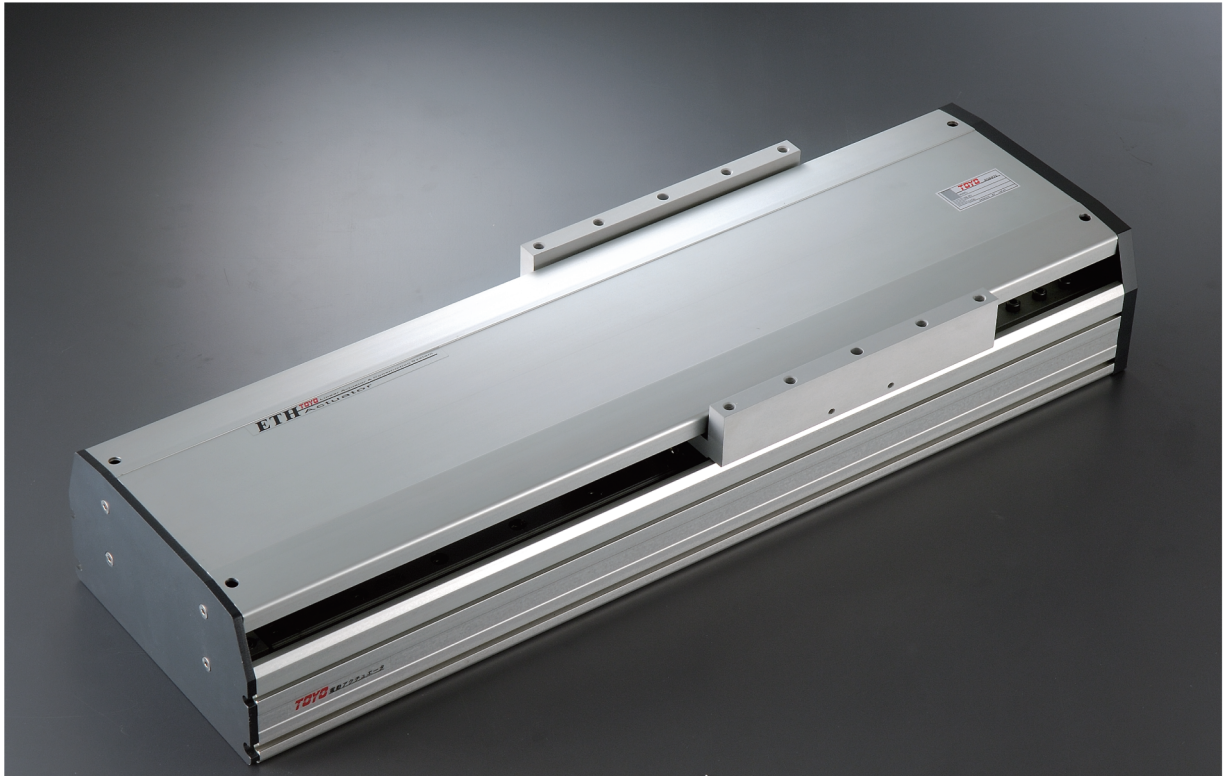

Maximum Stroke **1500mm**    Maximum Speed **2000mm/s**    Motor Output **750W**    Ball Screw  $\phi$ **25mm**    Linear Guide **Z3X18-2pc**

### Ordering Method

## ETH22 - L 10 - 100 - BC - M75B - C 4 - 0001

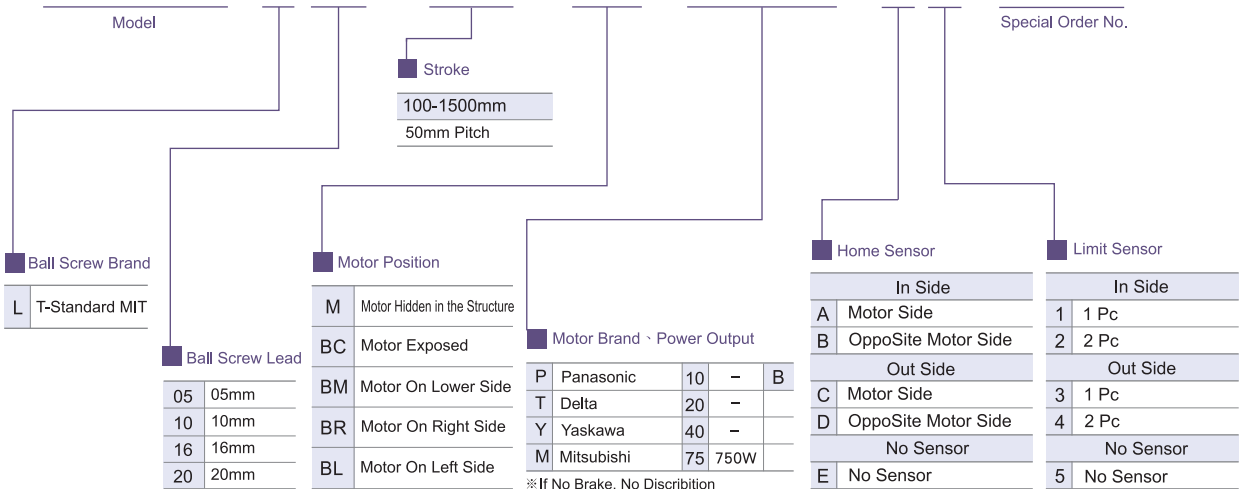

**Specification**

<b>Function</b>	Repeatability (mm)		±0.01			
	Belt Lead (mm)		5	10	25	40
	Maximum Speed (mm/s)		250	500	1250	2000
	Maximum Payload	Horizontal (kg)	150	150	120	60
		Vertical (kg)	55	45	20	10
	Rated Thrust (N)		2100	1050	420	320
	Stroke Pitch (mm)		100-1500mm / 50mm Pitch			
<b>Parts</b>	AC Servo Motor Output (w)		750			
	Ball Screw Ø (mm)		C7 φ 25	C7 φ 25	C7 φ 25	C7 φ 20
	High Rigidity Linear Guide (mm)		23X18			
	Coupling (mm)		19X17		19X12	
	Home Sensor	Outside	EE-SX672(NPN)			
Built In		EE-SX674(NPN)				

**Sensor Layout**

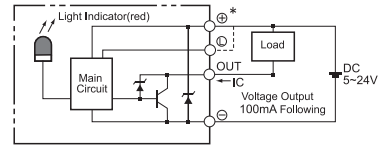

**Allowable Overhang N.m**

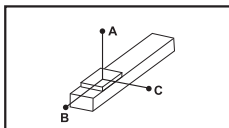

(Unit:mm)

Horizontal Installation	A	B	C
Lead 5	60kg	3672	653 866
	100kg	3000	370 497
	150kg	2493	273 363
Lead 10	60kg	2652	899 994
	100kg	1775	526 593
	150kg	1396	317 267
Lead 25	50kg	2862	956 1191
	80kg	2412	581 773
	120kg	2025	373 556
Lead 40	10kg	4010	4010 3460
	30kg	3011	2003 1911
	60kg	2453	730 980

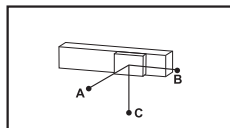

(Unit:mm)

Wall Installation	A	B	C
Lead 5	60kg	795	525 3657
	100kg	416	248 2993
	150kg	290	159 2479
Lead 10	60kg	982	815 2573
	100kg	569	442 1680
	150kg	337	232 1258
Lead 25	50kg	1207	879 2862
	80kg	779	504 2412
	120kg	515	295 2025
Lead 40	10kg	3057	4113 4113
	30kg	2112	2108 3387
	60kg	1020	668 2461

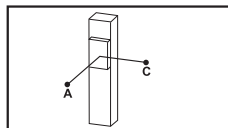

(Unit:mm)

Vertical Installation	A	C
Lead 5	30kg	2688 2688
	50kg	1893 1893
	70kg	1640 1640
Lead 10	20kg	2297 2297
	30kg	1518 1518
	45kg	999 999
Lead 25	15kg	2767 2767
	20kg	2100 2100
	25kg	1702 1702
Lead 40	-	- -
	-	- -
	-	- -

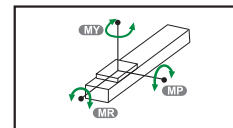

(Unit:N.m)

**Static Loading Moment**

MY	2052(N)
MP	2052(N)
MR	1810(N)

**Suitable Motor Brand**

Brand	Mark	Brake	Watp	AC-Voltage	Motor Model	Driver Model
Mitsubishi	M	No Brake (Horizontal Type)	750	220	HF-KP73	MR-J3-70A
		With Brake (Vertical Type)	750	220	HF-KP73B	MR-J3-70A
Panasonic	P	No Brake (Horizontal Type)	750	220	MHMD082P1S	MADDT3520
		With Brake (Vertical Type)	750	220	MHMD082P1T	MADDT3520
Delta	T	No Brake (Horizontal Type)	750	220	ECMA-C20807ES	ASD-B20721-B
		With Brake (Vertical Type)	750	220	ECMA-C20807FS	ASD-B20721-B

Application  
Standard Ball Screw  
Rod Type Actuator  
Standard Belt Type  
Clean Room Ball Screw  
Clean Room Belt Type  
Linear Motor  
Multi Axis  
Alignment Stage  
Reference

1 axis  
ETH  
ETH5M  
ETH6M  
ETH10  
ETH12  
ETH13  
ETH14  
ETH17  
ETH22

# ETH22

1-axis

Motor Exposed /  
Motor Hidden in the Structure

**BC** Motor Exposed



Welcome to download 2D/3D CAD and spec PDF

(mm)

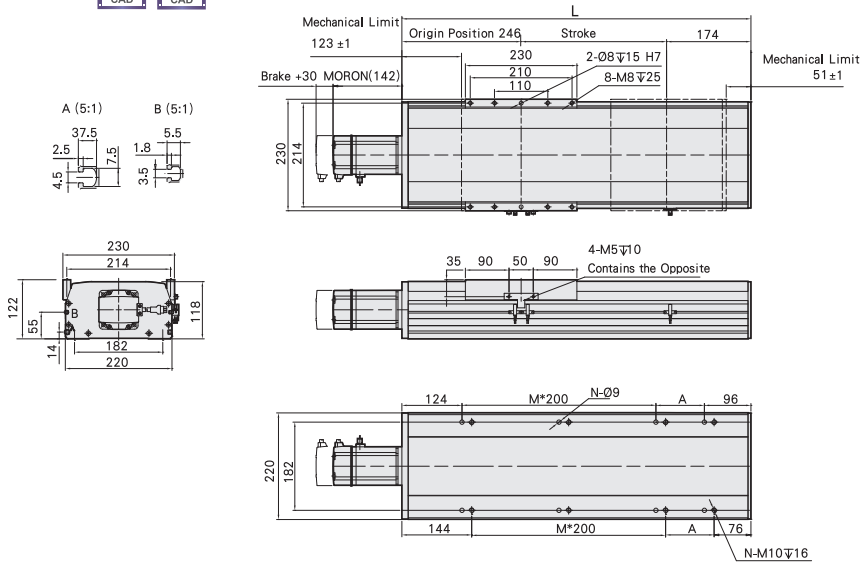

Stroke	100	150	200	250	300	350	400	450	500	550	600	650	700	750	800	850	900	950	1000	1050	1100	1150	1200	1250
L	520	570	620	670	720	770	820	870	920	970	1020	1070	1120	1170	1220	1270	1320	1370	1420	1470	1520	1570	1620	1670
A	100	150	200	50	100	150	200	50	100	150	200	50	100	150	200	50	100	150	200	50	100	150	200	50
M	1	1	1	2	2	2	2	3	3	3	3	4	4	4	4	5	5	5	5	6	6	6	6	7
N	6	6	6	8	8	8	8	10	10	10	10	12	12	12	12	14	14	14	14	16	16	16	16	18
KG	24.1	25.3	26.6	27.8	29	30.2	31.4	32.7	33.9	35.1	36.3	37.5	38.8	40	41.2	42.4	43.6	44.9	46.1	47.3	48.5	49.7	51	52.2

**M** Motor Hidden in the Structure



Welcome to download 2D/3D CAD and spec PDF

(mm)

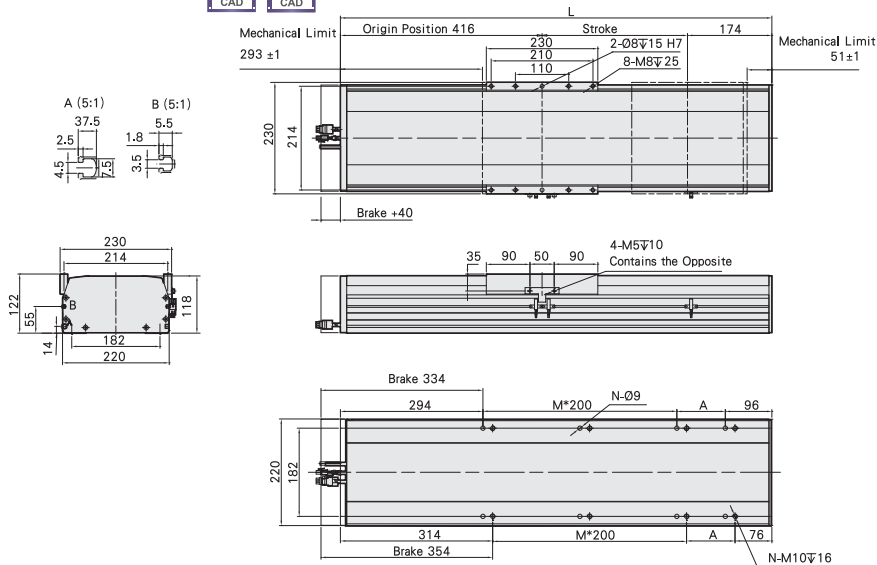

Stroke	100	150	200	250	300	350	400	450	500	550	600	650	700	750	800	850	900	950	1000	1050	1100	1150	1200	1250
L	690	740	790	840	890	940	990	1040	1090	1140	1190	1240	1290	1340	1390	1440	1490	1540	1590	1640	1690	1740	1790	1840
A	100	150	200	50	100	150	200	50	100	150	200	50	100	150	200	50	100	150	200	50	100	150	200	50
M	1	1	1	2	2	2	2	3	3	3	3	4	4	4	4	5	5	5	5	6	6	6	6	7
N	6	6	6	8	8	8	8	10	10	10	10	12	12	12	12	14	14	14	14	16	16	16	16	18
KG	24.1	25.3	26.6	27.8	29	30.2	31.4	32.7	33.9	35.1	36.3	37.5	38.8	40	41.2	42.4	43.6	44.9	46.1	47.3	48.5	49.7	51	52.2

Motor On Left Side /  
Motor On Right Side

Toll-Free Number : China 400-875-0009 Taiwan 0800-800-893

**BL**

Motor On Left Side



Welcome to download 2D/3D CAD and spec PDF

(mm)

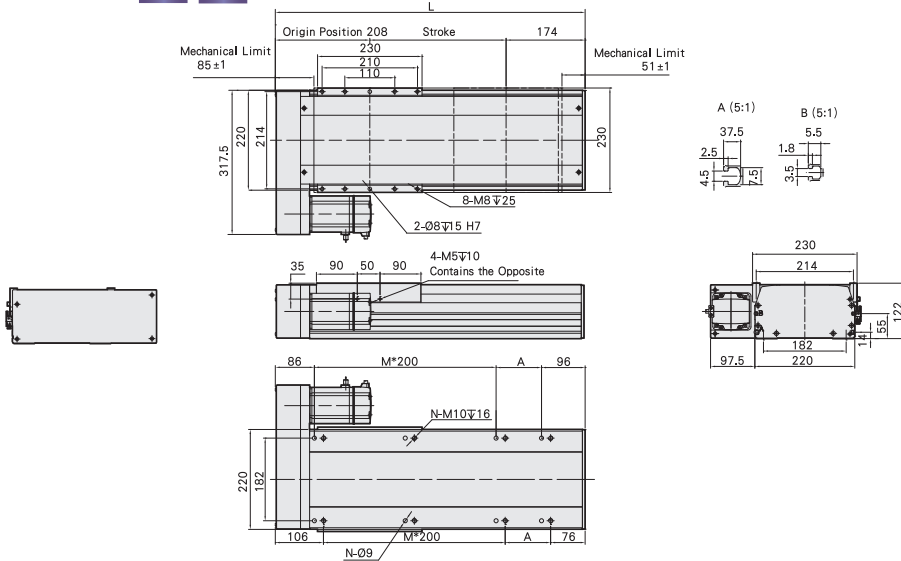

Stroke	100	150	200	250	300	350	400	450	500	550	600	650	700	750	800	850	900	950	1000	1050	1100	1150	1200	1250
L	482	532	582	632	682	732	782	832	882	932	982	1032	1082	1132	1182	1232	1282	1332	1382	1432	1482	1532	1582	1632
A	100	150	200	50	100	150	200	50	100	150	200	50	100	150	200	50	100	150	200	50	100	150	200	50
M	1	1	1	2	2	2	2	3	3	3	3	4	4	4	4	5	5	5	5	6	6	6	6	7
N	6	6	6	8	8	8	8	10	10	10	10	12	12	12	12	14	14	14	14	16	16	16	16	18
KG	24.1	25.3	26.6	27.8	29	30.2	31.4	32.7	33.9	35.1	36.3	37.5	38.8	40	41.2	42.4	43.6	44.9	46.1	47.3	48.5	49.7	51	52.2

**BR**

Motor On Right Side



Welcome to download 2D/3D CAD and spec PDF

(mm)

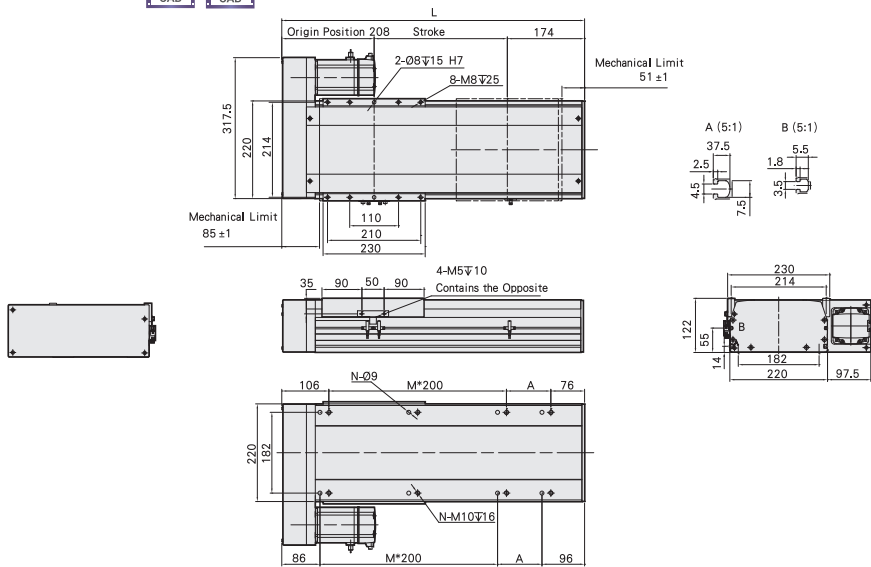

Stroke	100	150	200	250	300	350	400	450	500	550	600	650	700	750	800	850	900	950	1000	1050	1100	1150	1200	1250
L	482	532	582	632	682	732	782	832	882	932	982	1032	1082	1132	1182	1232	1282	1332	1382	1432	1482	1532	1582	1632
A	100	150	200	50	100	150	200	50	100	150	200	50	100	150	200	50	100	150	200	50	100	150	200	50
M	1	1	1	2	2	2	2	3	3	3	3	4	4	4	4	5	5	5	5	6	6	6	6	7
N	6	6	6	8	8	8	8	10	10	10	10	12	12	12	12	14	14	14	14	16	16	16	16	18
KG	24.1	25.3	26.6	27.8	29	30.2	31.4	32.7	33.9	35.1	36.3	37.5	38.8	40	41.2	42.4	43.6	44.9	46.1	47.3	48.5	49.7	51	52.2

Application

Standard Ball Screw

Rod Type Actuator

Standard Ball Type

Clean Room Ball Screw

Clean Room Ball Type

Linear Motor

Multi Axis

Alignment Stage

Reference

1 axis  
ETH

ETH5M

ETH6M

ETH10

ETH12

ETH13

ETH14

ETH17

ETH22

# ETH22

1-axis

Motor On Lower Side

BM Motor On Lower Side



Welcome to download 2D/3D CAD and spec PDF

(mm)

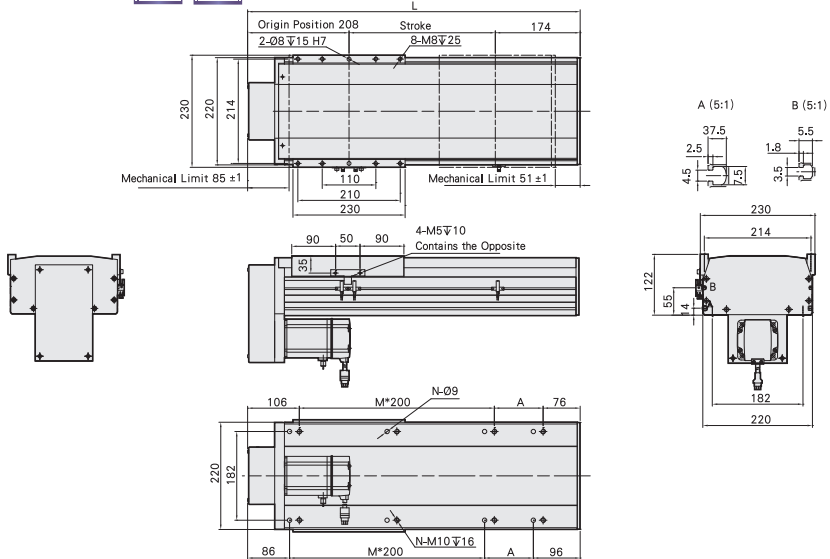

	100	150	200	250	300	350	400	450	500	550	600	650	700	750	800	850	900	950	1000	1050	1100	1150	1200	1250
L	482	532	582	632	682	732	782	832	882	932	982	1032	1082	1132	1182	1232	1282	1332	1382	1432	1482	1532	1582	1632
A	100	150	200	50	100	150	200	50	100	150	200	50	100	150	200	50	100	150	200	50	100	150	200	50
M	1	1	1	2	2	2	2	3	3	3	3	4	4	4	4	5	5	5	5	6	6	6	6	7
N	6	6	6	8	8	8	8	10	10	10	10	12	12	12	12	14	14	14	14	16	16	16	16	18
KG	24.1	25.3	26.6	27.8	29	30.2	31.4	32.7	33.9	35.1	36.3	37.5	38.8	40	41.2	42.4	43.6	44.9	46.1	47.3	48.5	49.7	51	52.2

Toll-Free Number : China 400-875-0009 Taiwan 0800-800-893

## MEMO

Application

Standard/Ball Screw

Rod Type Actuator

Standard/Belt Type

Clean Room/Ball Screw

Clean Room/Belt Type

Linear Motor

Multi Axis

Alignment Stage

Reference

### 1 axis ETH

ETH5M

ETH6M

ETH10

ETH12

ETH13

ETH14

ETH17

ETH22