

# ETH10

1-axis

Ball Screw Drive



Maximum Stroke **1050mm**    Maximum Speed **1000mm/s**    Motor Output **100W**    Ball Screw  $\phi$ **16mm**    Linear Guide **ZDX18-1pc**

## Ordering Method

# ETH10 - L 5 - 100 - M - M10B - C 4 - 0001

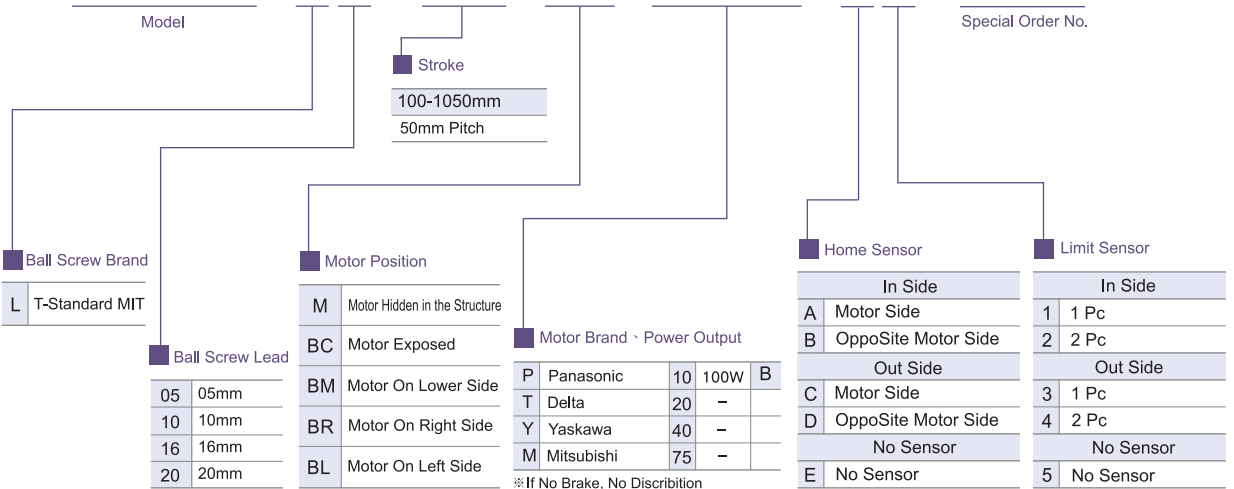

**Specification**

<b>Function</b>	Repeatability (mm)		±0.01			
	Belt Lead (mm)		5	10	16	20
	Maximum Speed (mm/s)		250	500	800	1000
	Maximum Payload	Horizontal (kg)	50	30	22	18
		Vertical (kg)	12	8	5	3
	Rated Thrust (N)		341	170	106	85
	Stroke Pitch (mm)		100-1050mm / 50mm Pitch			
<b>Parts</b>	AC Servo Motor Output (w)		100			
	Ball Screw Ø (mm)		C7 φ 16			
	High Rigidity Linear Guide (mm)		20X18			
	Coupling (mm)		8X10			
	Home Sensor	Outside	EE-SX672(NPN)			
Built In		EE-SX674(NPN)				

**Sensor Layout**

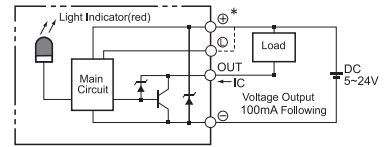

**Allowable Overhang N.m**

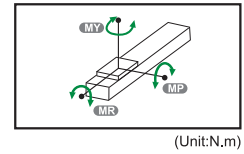
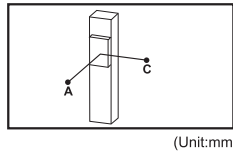
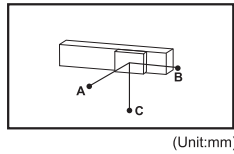
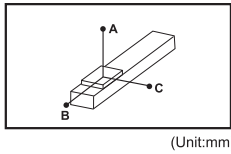

Horizontal Installation		A	B	C
Lead 5	30kg	424	24	25
	50kg	0	0	0
	-	-	-	-
Lead 10	15kg	394	76	79
	25kg	184	22	25
	30kg	111	-	-
Lead 16	5kg	937	282	259
	10kg	487	121	116
	22kg	236	40	44
Lead 20	5kg	940	285	264
	10kg	490	125	120
	15kg	240	45	48

Wall Installation		A	B	C
Lead 5	10kg	105	50	1400
	20kg	22	0	538
	30kg	0	0	0
Lead 10	10kg	100	50	545
	20kg	20	0	221
	30kg	0	0	0
Lead 16	5kg	116	58	605
	10kg	24	0	253
	22kg	0	0	0
Lead 20	5kg	251	211	903
	10kg	97	49	436
	15kg	23	0	153

Vertical Installation		A	C
Lead 5	5kg	100	145
	10kg	50	90
	12kg	23	63
Lead 10	4kg	335	375
	6kg	140	180
	8kg	100	140
Lead 16	1kg	620	620
	2kg	680	680
	5kg	310	350
Lead 20	1kg	580	580
	2kg	645	645
	3kg	310	350

Static Loading Moment

MY	110(N)
MP	110(N)
MR	120(N)

**Suitable Motor Brand**

Brand	Mark	Brake	Watp	AC-Voltage	Motor Model	Driver Model
Mitsubishi	M	No Brake (Horizontal Type)	100	220	HF-KP13	MR-J3-10A
		With Brake (Vertical Type)	100	220	HF-KP13B	MR-J3-10A
Panasonic	P	No Brake (Horizontal Type)	100	220	MSMD012P1S	MADDT1205
		With Brake (Vertical Type)	100	220	MSMD012P1T	MADDT1205
Delta	T	No Brake (Horizontal Type)	100	220	ECMA-C20401ES	ASD-B20121-B
		With Brake (Vertical Type)	100	220	ECMA-C20401FS	ASD-B20121-B

Application  
Standard/Ball Screw  
Rod Type Actuator  
Standard/Belt Type  
Clean Room/Ball Screw  
Clean Room/Belt Type  
Linear Motor  
Multi Axis  
Alignment Stage  
Reference

1 axis  
ETH  
ETH5M  
ETH6M  
ETH10  
ETH12  
ETH13  
ETH14  
ETH17  
ETH22

# ETH10

## 1-axis

Motor Exposed /  
Motor Hidden in the Structure

**BC** Motor Exposed



Welcome to download 2D/3D CAD and spec PDF

(mm)

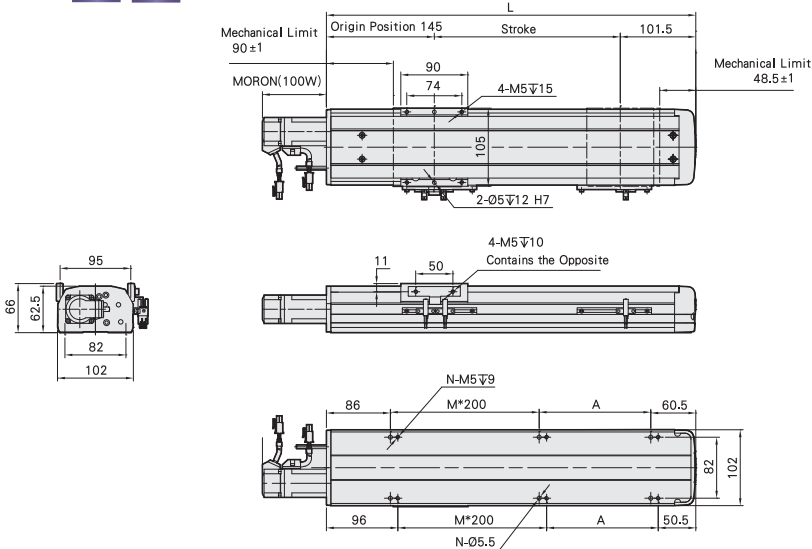

Stroke	100	150	200	250	300	350	400	450	500	550	600	650	700	750	800	850	900	950	1000	1050
L	346.5	396.5	446.5	496.5	546.5	596.5	646.5	696.5	746.5	796.5	846.5	896.5	946.5	996.5	1046.5	1096.5	1146.5	1196.5	1246.5	1296.5
A	200	50	100	150	200	50	100	150	200	50	100	150	200	50	100	150	200	50	100	150
M	0	1	1	1	1	2	2	2	2	3	3	3	3	4	4	4	4	5	5	5
N	4	6	6	6	6	8	8	8	8	10	10	10	10	12	12	12	12	14	14	14
KG	5.5	5.8	6.2	6.6	7	7.4	7.8	8.2	8.5	8.9	9.3	9.7	10.1	10.5	10.9	11.2	11.6	12	12.4	12.8

**M** Motor Hidden in the Structure



Welcome to download 2D/3D CAD and spec PDF

(mm)

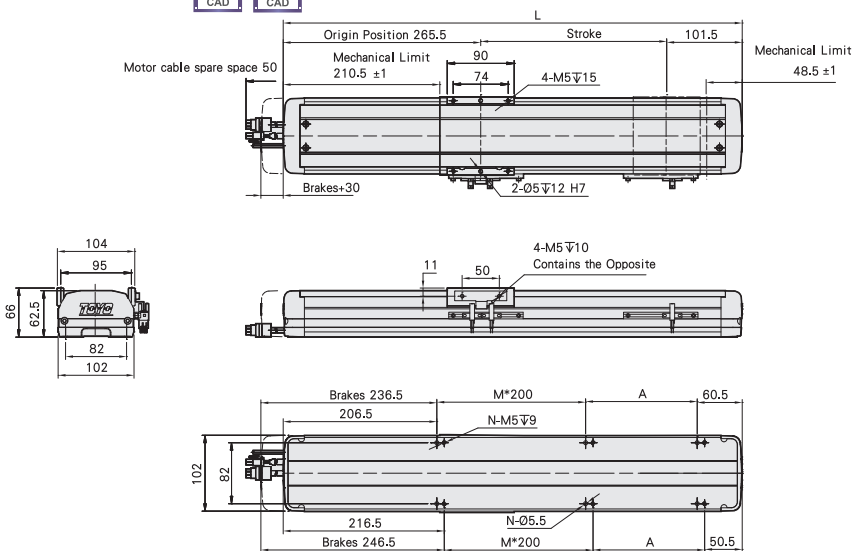

Stroke	100	150	200	250	300	350	400	450	500	550	600	650	700	750	800	850	900	950	1000	1050
L	467	517	567	617	667	717	767	817	867	917	967	1017	1067	1117	1167	1217	1267	1317	1367	1417
A	200	50	100	150	200	50	100	150	200	50	100	150	200	50	100	150	200	50	100	150
M	0	1	1	1	1	2	2	2	2	3	3	3	3	4	4	4	4	5	5	5
N	4	6	6	6	6	8	8	8	8	10	10	10	10	12	12	12	12	14	14	14
KG	5.5	5.8	6.2	6.6	7	7.4	7.8	8.2	8.5	8.9	9.3	9.7	10.1	10.5	10.9	11.2	11.6	12	12.4	12.8

Motor On Left Side /  
Motor On Right Side

Toll-Free Number : China 400-875-0009 Taiwan 0800-800-893

**BL** Motor On Left Side



Welcome to download 2D/3D CAD and spec PDF

(mm)

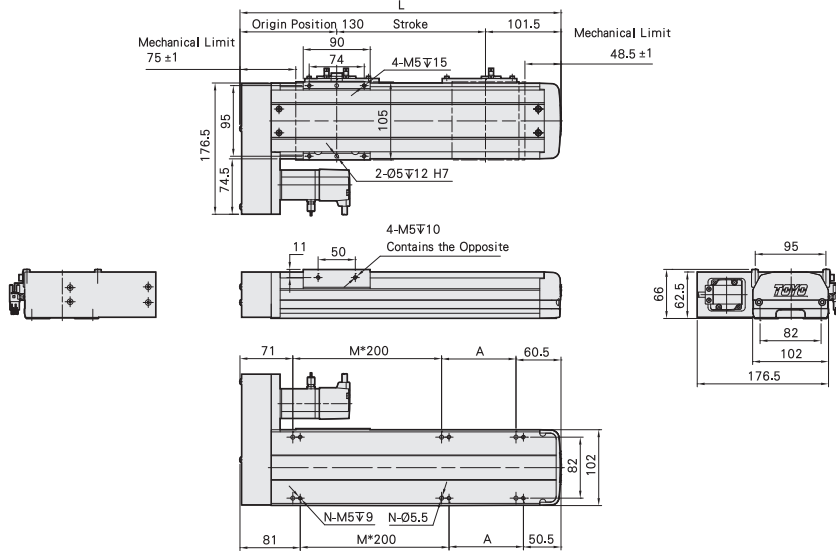

Stroke	100	150	200	250	300	350	400	450	500	550	600	650	700	750	800	850	900	950	1000	1050
L	331.5	381.5	431.5	481.5	531.5	581.5	631.5	681.5	731.5	781.5	831.5	881.5	931.5	981.5	1031.5	1081.5	1131.5	1181.5	1231.5	1281.5
A	200	50	100	150	200	50	100	150	200	50	100	150	200	50	100	150	200	50	100	150
M	0	1	1	1	1	2	2	2	2	3	3	3	3	3	4	4	4	5	5	5
N	4	6	6	6	6	8	8	8	8	10	10	10	10	12	12	12	12	14	14	14
KG	5.5	5.8	6.2	6.6	7	7.4	7.8	8.2	8.5	8.9	9.3	9.7	10.1	10.5	10.9	11.2	11.6	12	12.4	12.8

**BR** Motor On Right Side



Welcome to download 2D/3D CAD and spec PDF

(mm)

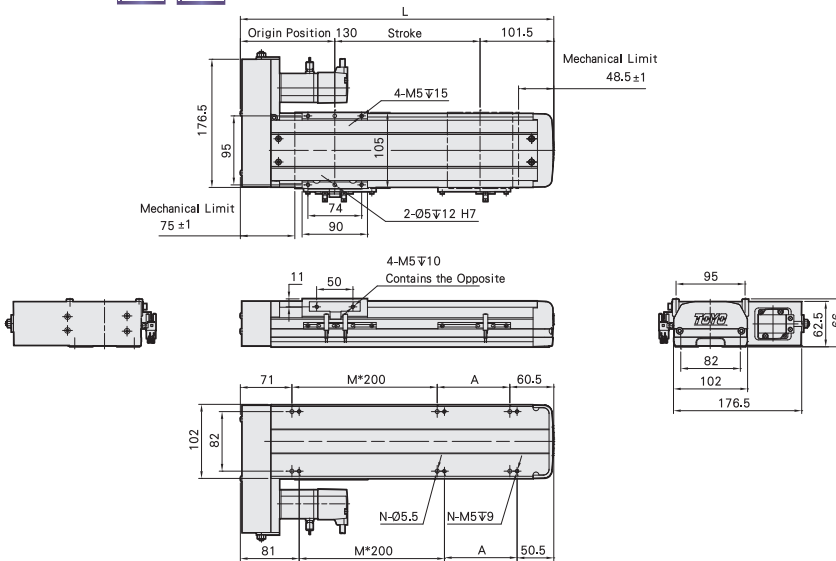

Stroke	100	150	200	250	300	350	400	450	500	550	600	650	700	750	800	850	900	950	1000	1050
L	331.5	381.5	431.5	481.5	531.5	581.5	631.5	681.5	731.5	781.5	831.5	881.5	931.5	981.5	1031.5	1081.5	1131.5	1181.5	1231.5	1281.5
A	200	50	100	150	200	50	100	150	200	50	100	150	200	50	100	150	200	50	100	150
M	0	1	1	1	1	2	2	2	2	3	3	3	3	3	4	4	4	5	5	5
N	4	6	6	6	6	8	8	8	8	10	10	10	10	12	12	12	12	14	14	14
KG	5.5	5.8	6.2	6.6	7	7.4	7.8	8.2	8.5	8.9	9.3	9.7	10.1	10.5	10.9	11.2	11.6	12	12.4	12.8

Application  
Standard Ball Screw  
Rod Type Actuator  
Standard Ball Type  
Clean Room Ball Screw  
Clean Room Ball Type  
Linear Motor  
Multi Axis  
Alignment Stage  
Reference

1 axis  
ETH  
ETH5M  
ETH6M  
ETH10  
ETH12  
ETH13  
ETH14  
ETH17  
ETH22

# ETH10

1-axis

Motor On Lower Side

BM Motor On Lower Side



Welcome to download 2D/3D CAD and spec PDF

(mm)

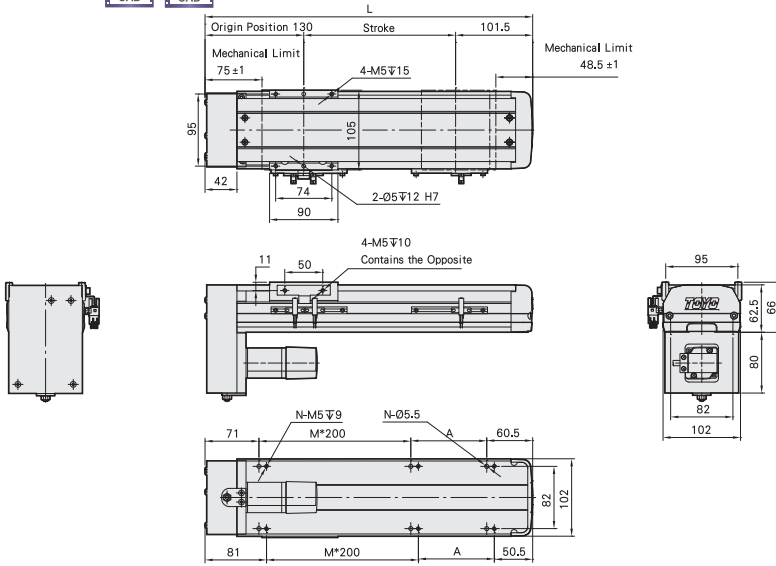

Stroke	100	150	200	250	300	350	400	450	500	550	600	650	700	750	800	850	900	950	1000	1050
L	331.5	381.5	431.5	481.5	531.5	581.5	631.5	681.5	731.5	781.5	831.5	881.5	931.5	981.5	1031.5	1081.5	1131.5	1181.5	1231.5	1281.5
A	200	50	100	150	200	50	100	150	200	50	100	150	200	50	100	150	200	50	100	150
M	0	1	1	1	1	2	2	2	2	3	3	3	3	4	4	4	4	5	5	5
N	4	6	6	6	6	8	8	8	8	10	10	10	10	12	12	12	12	14	14	14
KG	5.5	5.8	6.2	6.6	7	7.4	7.8	8.2	8.5	8.9	9.3	9.7	10.1	10.5	10.9	11.2	11.6	12	12.4	12.8

Toll-Free Number : China 400-875-0009 Taiwan 0800-800-893

**MEMO**

Application

Standard/Ball Screw

Rod Type Actuator

Standard/Belt Type

Clean Room/Ball Screw

Clean Room/Belt Type

Linear Motor

Multi Axis

Alignment Stage

Reference

**1 axis  
ETH**

ETH5M

ETH6M

**ETH10**

ETH12

ETH13

ETH14

ETH17

ETH22